

QZS-3 SATELLITE INFORMATION

Cabinet Office, Government of Japan
National Space Policy Secretariat
March 28, 2025 rev.F

1. Introduction

This documentation describes the information about QZS-3 GEO satellite properties which need to be known in order to properly implement advanced processing algorithms for precise orbit determination (POD) and precise point positioning (PPP) etc.

2. Reference Frame

The QZS-3 satellite coordinate system is aligned with the main body axes and originates at the center of the launch adapter plane. The individual axes of QZS-3 satellite coordinate system are aligned in the following way: (see Figure 1)

- origin : Center of the launch adapter plane
- The +Z-axis is oriented to the bore sight direction of the L-ANT antenna.
- The +Y-axis is parallel to the rotation axis of the solar panels.
- The +X-axis is constituted by a right handed system with +Y/+Z axis.

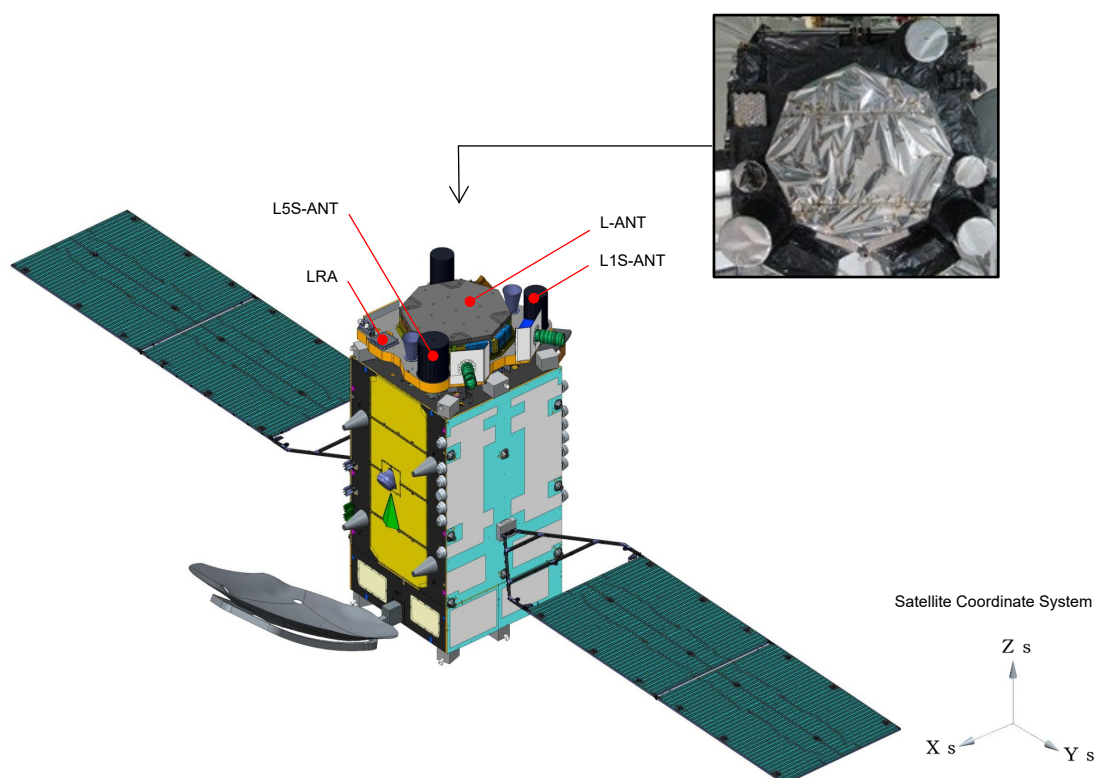

Figure 1 Reference frame

3. Attitude Law

QZS-3 is continuously controlled in the orbit normal mode as follows: (see Figure 3)

The +z-axis is pointing to the Earth.

The -y-axis is perpendicular to the orbital plane in the direction of the orbital angular momentum vector.

The +x-axis completes the right hand system with the y and z axes (oriented in the flight direction).

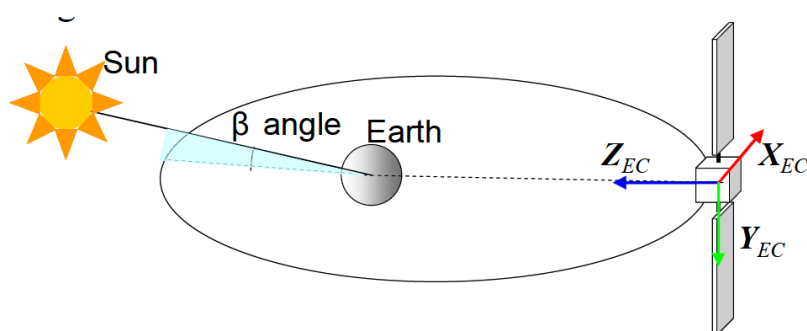

Figure 3 Orbit normal mode

4. Mass and Center Of Mass

The spacecraft mass and the center of mass with respect to the satellite reference frame are provided in Table 1.

Table 1 Mass and center of mass

	Mass [kg]	CoM (w.r.t. origin) [mm]		
		Xs	Ys	Zs
BOL	2762.6	0.2	1.0	1775.9
MOL	2379.2	0.2	1.2	1809.2
EOL	1995.9	0.3	1.4	1881.4

BOL : Completion of IOT(In Orbit Test) (Estimation)

MOL : 7.5 years after launch (Prediction)

EOL : 15 years after launch (Prediction)

5. Navigation Antenna Phase Center Corrections †

The phase center offsets of the navigation antennas are provided in Table 2. The offsets from the center of mass are obtained by subtracting the X/Y/Z coordinates in Table 1 from those in Table 2.

Table 2 Phase center location

Signal	Coordinates (w.r.t. origin) [mm]		
	X	Y	Z
L1	0.00	0.00	4743.89
L2	0.00	0.00	4623.89
L5	0.00	0.00	4423.89
L6	0.00	0.00	4863.89

The phase center variations of the navigation antenna are provided in Table 3, imitating the ANTEX format. The first column shows azimuth angles followed by PCVs at nadir angles from 0deg to 10deg at 0.5deg intervals. The azimuth angles count in the GNSS standard coordinate system, of which x and y axes are opposite to those of the QZS-3 satellite coordinate system respectively.

† PCO/PCV data are contained in the IGS ANTEX file:
<ftp://ftp.igs.org/pub/station/general/igs14.atx>

Table 3 Phase center variations (1/4)

(a) L1

NOAZI	0.00	-0.01	-0.05	-0.12	-0.20	-0.30	-0.41	-0.53	-0.65	-0.77	-0.90	-1.02	-1.12	-1.21	-1.27	-1.30	-1.31	-1.28	-1.24	-1.17	-1.10
0.0	0.00	-0.01	-0.04	-0.12	-0.20	-0.30	-0.43	-0.55	-0.66	-0.77	-0.89	-0.99	-1.09	-1.18	-1.26	-1.32	-1.36	-1.36	-1.33	-1.27	-1.17
10.0	0.00	-0.02	-0.09	-0.17	-0.26	-0.36	-0.49	-0.62	-0.74	-0.87	-1.03	-1.18	-1.29	-1.42	-1.51	-1.58	-1.60	-1.60	-1.58	-1.51	-1.41
20.0	0.00	-0.05	-0.12	-0.20	-0.31	-0.41	-0.54	-0.69	-0.85	-1.00	-1.15	-1.29	-1.41	-1.52	-1.60	-1.67	-1.68	-1.66	-1.58	-1.47	-1.30
30.0	0.00	-0.04	-0.10	-0.17	-0.26	-0.38	-0.50	-0.65	-0.76	-0.88	-1.06	-1.20	-1.32	-1.42	-1.51	-1.54	-1.55	-1.52	-1.45	-1.33	-1.19
40.0	0.00	-0.01	-0.05	-0.12	-0.20	-0.27	-0.37	-0.47	-0.58	-0.69	-0.81	-0.91	-1.00	-1.07	-1.13	-1.17	-1.18	-1.16	-1.09	-1.00	-0.86
50.0	0.00	0.01	-0.01	-0.07	-0.16	-0.27	-0.36	-0.47	-0.57	-0.66	-0.76	-0.85	-0.93	-0.98	-1.03	-1.06	-1.08	-1.08	-1.06	-0.99	-0.89
60.0	0.00	-0.01	-0.06	-0.13	-0.23	-0.33	-0.47	-0.60	-0.70	-0.82	-0.93	-1.02	-1.11	-1.18	-1.21	-1.23	-1.23	-1.21	-1.15	-1.08	-0.96
70.0	0.00	-0.02	-0.08	-0.15	-0.24	-0.35	-0.48	-0.60	-0.70	-0.85	-0.96	-1.05	-1.13	-1.20	-1.26	-1.28	-1.28	-1.27	-1.22	-1.11	-0.98
80.0	0.00	-0.01	-0.06	-0.11	-0.20	-0.30	-0.39	-0.48	-0.57	-0.68	-0.76	-0.84	-0.91	-0.99	-1.03	-1.05	-1.05	-1.04	-1.00	-0.93	-0.81
90.0	0.00	0.01	-0.01	-0.06	-0.13	-0.21	-0.28	-0.37	-0.44	-0.53	-0.59	-0.66	-0.72	-0.78	-0.82	-0.85	-0.87	-0.87	-0.86	-0.79	-0.70
100.0	0.00	0.01	-0.02	-0.08	-0.14	-0.21	-0.28	-0.37	-0.47	-0.58	-0.70	-0.82	-0.91	-0.99	-1.08	-1.10	-1.09	-1.06	-1.01	-0.98	-0.95
110.0	0.00	0.04	0.05	0.04	-0.00	-0.08	-0.18	-0.30	-0.46	-0.61	-0.85	-1.07	-1.22	-1.33	-1.41	-1.44	-1.44	-1.42	-1.38	-1.36	-1.38
120.0	0.00	0.01	0.01	-0.02	-0.08	-0.17	-0.29	-0.43	-0.59	-0.76	-0.93	-1.10	-1.25	-1.37	-1.44	-1.49	-1.50	-1.49	-1.47	-1.44	-1.43
130.0	0.00	-0.03	-0.09	-0.17	-0.27	-0.38	-0.48	-0.62	-0.74	-0.86	-1.00	-1.16	-1.28	-1.38	-1.46	-1.49	-1.50	-1.48	-1.44	-1.38	-1.32
140.0	0.00	-0.03	-0.11	-0.20	-0.29	-0.41	-0.54	-0.66	-0.80	-0.92	-1.05	-1.23	-1.34	-1.43	-1.50	-1.50	-1.49	-1.47	-1.44	-1.40	-1.52
150.0	0.00	-0.03	-0.06	-0.11	-0.22	-0.35	-0.49	-0.65	-0.81	-0.99	-1.19	-1.37	-1.54	-1.68	-1.79	-1.85	-1.86	-1.87	-1.85	-1.82	-1.81
160.0	0.00	0.01	-0.00	-0.05	-0.12	-0.23	-0.34	-0.45	-0.63	-0.84	-1.04	-1.25	-1.60	-1.75	-1.85	-1.92	-1.95	-1.96	-1.96	-1.97	-1.99
170.0	0.00	0.01	-0.02	-0.09	-0.18	-0.29	-0.44	-0.56	-0.73	-0.86	-1.01	-1.15	-1.40	-1.58	-1.66	-1.73	-1.77	-1.78	-1.78	-1.77	-1.76
180.0	0.00	-0.03	-0.09	-0.18	-0.29	-0.42	-0.55	-0.67	-0.79	-0.91	-1.03	-1.13	-1.24	-1.30	-1.37	-1.41	-1.44	-1.40	-1.53	-1.50	-1.47
190.0	0.00	-0.03	-0.06	-0.14	-0.23	-0.35	-0.49	-0.62	-0.74	-0.89	-1.04	-1.17	-1.28	-1.38	-1.45	-1.48	-1.50	-1.47	-1.46	-1.43	-1.40
200.0	0.00	0.03	0.02	-0.01	-0.08	-0.15	-0.26	-0.39	-0.53	-0.69	-0.84	-0.99	-1.14	-1.22	-1.29	-1.31	-1.31	-1.33	-1.33	-1.34	-1.39
210.0	0.00	0.02	0.02	-0.02	-0.07	-0.14	-0.20	-0.29	-0.40	-0.52	-0.64	-0.78	-0.90	-0.98	-1.02	-1.07	-1.06	-1.03	-1.00	-1.00	-0.99
220.0	0.00	-0.02	-0.07	-0.13	-0.19	-0.24	-0.30	-0.34	-0.38	-0.46	-0.55	-0.60	-0.67	-0.72	-0.74	-0.73	-0.70	-0.65	-0.59	-0.52	-0.46
230.0	0.00	-0.04	-0.11	-0.17	-0.25	-0.32	-0.38	-0.41	-0.45	-0.50	-0.56	-0.59	-0.61	-0.63	-0.72	-0.75	-0.77	-0.71	-0.65	-0.59	-0.53
240.0	0.00	-0.02	-0.05	-0.10	-0.17	-0.23	-0.30	-0.38	-0.45	-0.53	-0.60	-0.66	-0.73	-0.86	-0.95	-0.99	-0.98	-0.97	-0.94	-0.91	-0.89
250.0	0.00	-0.00	-0.03	-0.07	-0.13	-0.21	-0.28	-0.38	-0.48	-0.58	-0.68	-0.76	-0.85	-1.01	-1.12	-1.15	-1.17	-1.16	-1.14	-1.13	-1.12
260.0	0.00	-0.01	-0.05	-0.10	-0.16	-0.23	-0.31	-0.40	-0.49	-0.58	-0.69	-0.81	-0.91	-0.98	-1.06	-1.09	-1.09	-1.08	-1.05	-1.03	-1.01
270.0	0.00	-0.03	-0.06	-0.13	-0.23	-0.30	-0.38	-0.47	-0.57	-0.65	-0.77	-0.86	-0.94	-1.01	-1.08	-1.12	-1.13	-1.11	-1.08	-1.02	-0.96
280.0	0.00	-0.03	-0.08	-0.14	-0.22	-0.33	-0.46	-0.58	-0.69	-0.82	-0.95	-1.06	-1.15	-1.22	-1.29	-1.32	-1.34	-1.34	-1.29	-1.21	-1.06
290.0	0.00	-0.06	-0.15	-0.24	-0.35	-0.47	-0.60	-0.73	-0.90	-1.03	-1.17	-1.31	-1.41	-1.49	-1.55	-1.57	-1.54	-1.46	-1.36	-1.19	-0.98
300.0	0.00	0.01	-0.02	-0.11	-0.24	-0.38	-0.53	-0.67	-0.81	-0.95	-1.11	-1.22	-1.33	-1.41	-1.46	-1.45	-1.41	-1.34	-1.21	-1.05	-0.82
310.0	0.00	-0.02	-0.07	-0.17	-0.28	-0.38	-0.50	-0.62	-0.72	-0.82	-0.91	-0.99	-1.05	-1.10	-1.11	-1.11	-1.08	-0.99	-0.91	-0.76	-0.58
320.0	0.00	0.01	0.02	-0.07	-0.16	-0.28	-0.41	-0.57	-0.68	-0.81	-0.91	-0.97	-1.02	-1.03	-1.05	-1.05	-1.02	-0.95	-0.87	-0.77	-0.61
330.0	0.00	-0.00	-0.01	-0.10	-0.21	-0.35	-0.48	-0.63	-0.79	-0.94	-1.09	-1.18	-1.22	-1.22	-1.22	-1.22	-1.21	-1.13	-1.04	-0.92	-0.78
340.0	0.00	-0.02	-0.08	-0.12	-0.24	-0.33	-0.49	-0.64	-0.82	-0.95	-1.10	-1.23	-1.33	-1.38	-1.42	-1.43	-1.40	-1.34	-1.25	-1.11	-0.96
350.0	0.00	-0.01	-0.08	-0.16	-0.26	-0.39	-0.52	-0.67	-0.80	-0.92	-1.04	-1.16	-1.26	-1.34	-1.39	-1.42	-1.42	-1.39	-1.31	-1.21	-1.08
360.0	0.00	-0.01	-0.04	-0.12	-0.20	-0.30	-0.43	-0.55	-0.66	-0.77	-0.89	-0.99	-1.09	-1.18	-1.26	-1.32	-1.36	-1.36	-1.33	-1.27	-1.17

Table 3 Phase center variations (2/4)

(b) L2

NOAZI	0.00	-0.00	0.00	0.02	0.03	0.04	0.06	0.08	0.10	0.11	0.13	0.15	0.16	0.17	0.18	0.18	0.18	0.18	0.17	0.20	0.26
0.0	0.00	0.02	0.05	0.08	0.12	0.15	0.19	0.24	0.30	0.32	0.33	0.35	0.38	0.42	0.42	0.45	0.48	0.50	0.49	0.50	0.47
10.0	0.00	0.05	0.06	0.11	0.14	0.20	0.23	0.23	0.27	0.32	0.36	0.38	0.42	0.46	0.49	0.50	0.55	0.54	0.52	0.50	0.45
20.0	0.00	0.03	0.05	0.08	0.15	0.18	0.21	0.26	0.34	0.39	0.52	0.61	0.67	0.71	0.75	0.78	0.83	0.88	0.87	0.84	0.78
30.0	0.00	0.02	0.06	0.12	0.15	0.19	0.21	0.27	0.33	0.37	0.44	0.53	0.74	0.77	0.75	0.77	0.78	0.81	0.84	0.81	0.80
40.0	0.00	0.00	0.08	0.08	0.11	0.07	0.09	0.12	0.14	0.13	0.20	0.23	0.22	0.20	0.22	0.23	0.22	0.19	0.19	0.17	0.16
50.0	0.00	0.04	0.03	0.03	0.03	-0.00	-0.01	0.02	0.03	-0.01	0.02	-0.00	-0.01	0.03	-0.01	-0.03	-0.02	-0.03	-0.04	-0.05	-0.06
60.0	0.00	-0.00	-0.01	0.05	0.01	0.02	0.06	0.06	0.09	0.09	0.11	0.10	0.10	0.09	0.08	0.08	0.12	0.13	0.15	0.15	0.31
70.0	0.00	0.01	0.01	-0.00	0.01	0.03	0.03	0.07	0.10	0.14	0.11	0.13	0.15	0.11	0.15	0.16	0.17	0.19	0.21	0.21	0.28
80.0	0.00	0.02	0.05	0.06	0.09	0.10	0.10	0.11	0.11	0.11	0.11	0.23	0.31	0.40	0.47	0.53	0.49	0.46	0.41	0.39	0.36
90.0	0.00	0.03	0.02	0.04	0.06	0.06	0.03	0.00	0.01	-0.03	-0.08	-0.11	-0.14	-0.17	-0.20	-0.22	-0.23	-0.23	-0.26	-0.27	-0.30
100.0	0.00	0.00	0.04	0.06	0.04	0.02	0.01	0.01	-0.01	-0.01	-0.05	-0.08	-0.11	-0.13	-0.14	-0.16	-0.17	-0.20	-0.42	-0.39	-0.33
110.0	0.00	0.00	0.02	0.05	0.04	0.05	0.05	0.06	0.07	0.06	0.07	0.06	0.03	-0.01	-0.22	-0.25	-0.28	-0.30	-0.35	-0.34	-0.26
120.0	0.00	0.01	0.02	0.04	0.07	0.08	0.12	0.19	0.12	0.13	0.07	-0.00	-0.03	-0.05	-0.06	-0.06	-0.06	-0.04	0.01	0.13	0.13
130.0	0.00	-0.03	-0.02	-0.06	-0.06	-0.05	-0.03	0.00	0.05	0.09	0.15	0.15	0.15	0.18	0.19	0.20	0.20	0.22	0.27	0.33	0.41
140.0	0.00	0.04	0.01	-0.00	-0.00	0.05	0.04	0.09	0.16	0.17	0.23	0.29	0.33	0.41	0.48	0.51	0.54	0.55	0.38	0.47	0.61
150.0	0.00	0.07	0.09	0.09	0.06	0.11	0.15	0.19	0.22	0.29	0.34	0.38	0.46	0.47	0.57	0.68	0.42	0.44	0.51	0.59	0.74
160.0	0.00	0.01	0.05	0.08	0.10	0.12	0.19	0.24	0.27	0.32	0.37	0.41	0.46	0.54	0.54	0.61	0.69	0.50	0.56	0.67	0.80
170.0	0.00	-0.01	-0.02	-0.00	0.00	0.04	0.08	0.12	0.14	0.18	0.22	0.26	0.32	0.39	0.42	0.51	0.58	0.40	0.48	0.60	0.74
180.0	0.00	-0.02	-0.06	-0.04	-0.02	0.01	0.02	0.07	0.10	0.13	0.18	0.22	0.27	0.32	0.14	0.13	0.16	0.19	0.25	0.36	0.50
190.0	0.00	-0.14	-0.19	-0.28	-0.28	-0.27	-0.26	-0.24	-0.22	-0.20	-0.18	-0.18	-0.18	-0.18	-0.17	-0.19	-0.17	-0.14	-0.10	-0.02	0.11
200.0	0.00	-0.01	-0.03	-0.03	-0.01	-0.01	-0.00	-0.01	-0.01	-0.00	0.03	0.04	0.03	-0.06	-0.07	-0.09	-0.10	-0.10	-0.09	-0.03	0.06
210.0	0.00	-0.00	-0.01	-0.02	-0.02	-0.03	-0.02	0.00	0.01	-0.02	-0.03	-0.04	-0.04	-0.05	-0.04	-0.15	-0.15	-0.16	-0.14	-0.09	0.02
220.0	0.00	-0.03	-0.03	-0.04	-0.03	-0.01	-0.00	-0.09	-0.10	-0.08	-0.11	-0.14	-0.15	-0.13	-0.12	-0.14	-0.22	-0.20	-0.14	-0.10	0.05
230.0	0.00	0.00	-0.01	0.01	0.01	0.01	0.02	0.00	-0.06	-0.10	-0.12	-0.13	-0.18	-0.22	-0.20	-0.22	-0.25	-0.33	-0.27	-0.19	-0.10
240.0	0.00	-0.06	-0.05	-0.01	-0.04	-0.04	-0.03	-0.02	-0.07	-0.15	-0.16	-0.22	-0.27	-0.31	-0.35	-0.34	-0.36	-0.40	-0.36	-0.32	-0.22
250.0	0.00	-0.06	-0.07	-0.05	-0.06	-0.05	-0.06	-0.05	-0.11	-0.14	-0.15	-0.21	-0.29	-0.32	-0.31	-0.36	-0.38	-0.41	-0.39	-0.34	-0.21
260.0	0.00	-0.02	-0.06	-0.04	-0.04	-0.07	-0.10	-0.12	-0.16	-0.20	-0.23	-0.25	-0.28	-0.35	-0.33	-0.34	-0.40	-0.42	-0.41	-0.36	-0.23
270.0	0.00	0.01	0.01	0.02	0.02	0.01	-0.02	-0.06	-0.07	-0.10	-0.10	-0.13	-0.16	-0.22	-0.21	-0.17	-0.15	-0.20	-0.35	-0.34	-0.17
280.0	0.00	0.01	0.02	0.01	-0.00	0.02	0.04	0.04	0.02	0.03	0.05	0.06	0.07	0.08	0.10	0.09	0.06	0.07	0.05	0.03	-0.04
290.0	0.00	-0.01	-0.03	-0.01	0.02	0.04	0.06	0.10	0.13	0.14	0.17	0.21	0.25	0.26	0.27	0.28	0.28	0.25	0.21	0.17	0.11
300.0	0.00	-0.01	-0.00	0.01	0.03	0.05	0.10	0.13	0.17	0.21	0.24	0.28	0.33	0.36	0.36	0.36	0.38	0.39	0.37	0.35	0.27
310.0	0.00	0.00	0.01	0.04	0.08	0.10	0.12	0.13	0.18	0.20	0.21	0.22	0.24	0.36	0.36	0.29	0.29	0.25	0.22	0.22	0.16
320.0	0.00	-0.00	0.00	0.02	0.03	0.04	0.10	0.10	0.11	0.14	0.16	0.21	0.21	0.22	0.22	0.22	0.23	0.25	0.22	0.20	0.19
330.0	0.00	0.01	0.02	0.03	0.02	0.08	0.14	0.17	0.22	0.26	0.31	0.36	0.41	0.47	0.52	0.55	0.57	0.61	0.67	0.71	0.71
340.0	0.00	-0.01	-0.00	0.02	0.07	0.14	0.16	0.22	0.30	0.37	0.44	0.52	0.57	0.60	0.66	0.71	0.75	0.85	0.92	0.99	1.02
350.0	0.00	-0.00	0.02	0.04	0.10	0.16	0.25	0.31	0.37	0.43	0.47	0.53	0.60	0.64	0.67	0.72	0.76	0.83	0.88	0.94	0.94
360.0	0.00	0.02	0.05	0.08	0.12	0.15	0.19	0.24	0.30	0.32	0.33	0.35	0.38	0.42	0.42	0.45	0.48	0.50	0.49	0.50	0.47

Table 3 Phase center variations (3/4)

(c) L5

NOAZI	0.00	0.01	0.02	0.04	0.06	0.10	0.14	0.20	0.28	0.37	0.47	0.58	0.69	0.81	0.93	1.03	1.13	1.21	1.25	1.27	1.26
0.0	0.00	0.04	0.10	0.17	0.26	0.34	0.41	0.50	0.60	0.72	0.83	0.96	1.09	1.23	1.34	1.40	1.48	1.51	1.50	1.48	1.47
10.0	0.00	0.04	0.13	0.18	0.28	0.37	0.45	0.55	0.67	0.81	0.94	1.10	1.26	1.38	1.52	1.61	1.70	1.77	1.80	1.77	1.76
20.0	0.00	0.06	0.12	0.16	0.28	0.37	0.47	0.58	0.72	0.86	1.01	1.16	1.33	1.49	1.63	1.74	1.86	1.93	1.97	1.99	1.98
30.0	0.00	0.07	0.14	0.20	0.28	0.37	0.47	0.58	0.72	0.85	0.97	1.14	1.34	1.54	1.72	1.80	1.91	1.97	2.02	2.07	2.09
40.0	0.00	0.07	0.11	0.20	0.31	0.42	0.49	0.59	0.67	0.78	0.91	1.06	1.21	1.35	1.51	1.67	1.83	1.94	2.02	2.02	2.01
50.0	0.00	0.06	0.11	0.17	0.25	0.33	0.44	0.55	0.61	0.70	0.77	0.92	1.02	1.14	1.27	1.38	1.50	1.62	1.64	1.60	1.58
60.0	0.00	0.04	0.10	0.14	0.20	0.28	0.38	0.50	0.60	0.67	0.77	0.89	1.04	1.16	1.32	1.45	1.53	1.59	1.55	1.52	1.45
70.0	0.00	0.05	0.09	0.14	0.20	0.24	0.31	0.38	0.48	0.57	0.69	0.80	0.90	1.00	1.12	1.20	1.28	1.32	1.33	1.31	1.26
80.0	0.00	0.07	0.09	0.12	0.18	0.25	0.31	0.38	0.46	0.55	0.71	0.83	0.93	1.04	1.15	1.23	1.32	1.36	1.37	1.37	1.35
90.0	0.00	0.06	0.09	0.14	0.22	0.26	0.31	0.38	0.46	0.55	0.65	0.78	0.90	1.01	1.10	1.19	1.28	1.35	1.37	1.39	1.41
100.0	0.00	0.02	0.04	0.08	0.10	0.14	0.19	0.23	0.29	0.38	0.44	0.54	0.64	0.72	0.85	0.97	1.06	1.14	1.20	1.24	1.23
110.0	0.00	-0.01	0.00	-0.01	-0.02	-0.01	0.01	0.02	0.06	0.13	0.21	0.28	0.38	0.50	0.63	0.75	0.88	0.99	1.07	1.17	1.19
120.0	0.00	-0.03	-0.03	-0.04	-0.04	-0.03	0.01	0.05	0.12	0.22	0.32	0.46	0.49	0.62	0.80	0.93	1.08	1.23	1.34	1.36	1.39
130.0	0.00	-0.02	-0.03	-0.01	0.01	0.06	0.12	0.18	0.29	0.41	0.55	0.69	0.83	0.97	1.13	1.29	1.45	1.61	1.68	1.75	1.83
140.0	0.00	-0.01	0.02	0.03	0.06	0.10	0.17	0.26	0.42	0.53	0.66	0.81	0.95	1.09	1.27	1.44	1.61	1.71	1.85	1.95	2.03
150.0	0.00	-0.02	-0.02	-0.00	0.00	0.02	0.08	0.16	0.25	0.38	0.49	0.57	0.69	0.85	1.02	1.19	1.33	1.47	1.60	1.69	1.73
160.0	0.00	-0.04	-0.06	-0.05	-0.06	-0.06	-0.00	0.08	0.17	0.28	0.40	0.56	0.73	0.85	0.88	1.09	1.17	1.33	1.46	1.58	1.63
170.0	0.00	-0.04	-0.04	-0.04	-0.03	0.03	0.06	0.12	0.21	0.33	0.50	0.65	0.84	0.99	1.20	1.42	1.60	1.59	1.70	1.81	1.79
180.0	0.00	-0.01	-0.03	-0.01	-0.00	0.08	0.16	0.21	0.27	0.41	0.55	0.69	0.85	1.01	1.18	1.31	1.47	1.60	1.71	1.80	1.83
190.0	0.00	-0.02	-0.03	-0.01	-0.00	0.03	0.09	0.19	0.30	0.39	0.50	0.61	0.74	0.87	1.01	1.16	1.30	1.42	1.54	1.61	1.61
200.0	0.00	-0.04	-0.13	-0.20	-0.21	-0.22	-0.29	-0.23	-0.17	-0.10	-0.01	0.09	0.22	0.34	0.45	0.57	0.71	0.83	0.92	0.98	0.98
210.0	0.00	-0.06	-0.09	-0.11	-0.13	-0.12	-0.09	-0.05	0.02	0.11	0.20	0.30	0.42	0.56	0.67	0.76	0.86	0.95	1.03	1.06	1.04
220.0	0.00	-0.05	-0.08	-0.06	-0.05	-0.03	-0.03	0.04	0.11	0.22	0.32	0.43	0.54	0.70	0.82	0.88	0.98	1.04	1.08	1.09	1.08
230.0	0.00	-0.04	-0.04	-0.04	-0.06	-0.06	-0.04	0.01	0.08	0.16	0.22	0.32	0.40	0.49	0.57	0.66	0.72	0.76	0.77	0.79	0.72
240.0	0.00	-0.03	-0.06	-0.10	-0.10	-0.12	-0.12	-0.11	-0.06	-0.03	0.02	0.07	0.12	0.19	0.27	0.32	0.35	0.40	0.40	0.37	0.23
250.0	0.00	-0.04	-0.08	-0.11	-0.15	-0.18	-0.19	-0.18	-0.18	-0.16	-0.12	-0.08	-0.03	0.03	0.11	0.18	0.24	0.23	0.23	0.19	0.11
260.0	0.00	-0.01	-0.04	-0.08	-0.14	-0.15	-0.15	-0.15	-0.10	-0.06	-0.03	0.02	0.07	0.15	0.23	0.30	0.35	0.39	0.39	0.37	0.29
270.0	0.00	-0.03	-0.04	-0.06	-0.07	-0.05	-0.05	-0.01	0.02	0.08	0.13	0.20	0.25	0.32	0.41	0.49	0.57	0.60	0.62	0.62	0.56
280.0	0.00	-0.02	-0.04	-0.05	-0.07	-0.07	-0.07	-0.06	-0.02	0.03	0.08	0.17	0.24	0.33	0.41	0.50	0.57	0.62	0.63	0.63	0.64
290.0	0.00	0.01	0.01	0.00	0.01	0.01	0.01	0.05	0.08	0.12	0.18	0.28	0.37	0.46	0.56	0.66	0.74	0.79	0.83	0.85	0.87
300.0	0.00	0.01	0.03	0.04	0.05	0.05	0.07	0.10	0.14	0.17	0.24	0.33	0.43	0.52	0.62	0.71	0.79	0.86	0.91	0.94	0.97
310.0	0.00	0.01	0.03	0.06	0.09	0.11	0.13	0.20	0.23	0.28	0.39	0.48	0.53	0.59	0.67	0.76	0.82	0.86	0.90	0.93	0.97
320.0	0.00	-0.00	-0.01	0.03	0.08	0.12	0.14	0.18	0.23	0.32	0.42	0.52	0.55	0.59	0.67	0.71	0.78	0.80	0.81	0.80	0.77
330.0	0.00	0.03	0.05	0.10	0.12	0.16	0.21	0.24	0.33	0.42	0.50	0.62	0.72	0.82	0.92	1.01	1.06	1.10	1.09	1.09	1.03
340.0	0.00	0.05	0.06	0.09	0.12	0.18	0.22	0.30	0.38	0.47	0.57	0.70	0.83	0.94	1.06	1.15	1.23	1.28	1.25	1.20	1.15
350.0	0.00	0.05	0.10	0.17	0.21	0.31	0.39	0.46	0.54	0.64	0.77	0.91	1.03	1.14	1.26	1.36	1.40	1.44	1.44	1.42	1.37
360.0	0.00	0.04	0.10	0.17	0.26	0.34	0.41	0.50	0.60	0.72	0.83	0.96	1.09	1.23	1.34	1.40	1.48	1.51	1.50	1.48	1.47

Table 3 Phase center variations (4/4)

(d) L6

NOAZI	0.00	-0.00	-0.02	-0.05	-0.09	-0.13	-0.17	-0.21	-0.24	-0.26	-0.26	-0.24	-0.20	-0.14	-0.05	0.06	0.19	0.35	0.53	0.73	0.95
0.0	0.00	-0.00	-0.05	-0.15	-0.21	-0.26	-0.33	-0.39	-0.46	-0.52	-0.55	-0.57	-0.55	-0.55	-0.50	-0.40	-0.27	-0.12	0.08	0.30	0.55
10.0	0.00	-0.03	-0.09	-0.20	-0.29	-0.39	-0.50	-0.61	-0.70	-0.79	-0.88	-0.94	-0.96	-0.97	-0.96	-0.91	-0.80	-0.70	-0.59	-0.43	-0.25
20.0	0.00	-0.01	-0.04	-0.13	-0.24	-0.35	-0.47	-0.58	-0.68	-0.77	-0.85	-0.90	-0.92	-0.92	-0.91	-0.88	-0.80	-0.67	-0.58	-0.46	-0.31
30.0	0.00	-0.02	-0.08	-0.18	-0.25	-0.34	-0.41	-0.50	-0.57	-0.65	-0.58	-0.55	-0.60	-0.62	-0.59	-0.55	-0.49	-0.38	-0.28	-0.10	0.06
40.0	0.00	-0.02	-0.08	-0.10	-0.17	-0.26	-0.29	-0.34	-0.37	-0.41	-0.43	-0.43	-0.34	-0.36	-0.31	-0.21	-0.12	0.00	0.10	0.28	0.51
50.0	0.00	0.01	-0.01	-0.08	-0.14	-0.17	-0.18	-0.21	-0.21	-0.21	-0.24	-0.23	-0.18	-0.13	-0.07	0.02	0.18	0.31	0.46	0.68	0.94
60.0	0.00	0.00	-0.01	-0.05	-0.07	-0.06	-0.09	-0.11	-0.13	-0.10	-0.10	-0.06	-0.00	0.07	0.16	0.32	0.45	0.62	0.83	1.08	1.36
70.0	0.00	-0.03	-0.03	-0.02	-0.02	-0.03	-0.01	0.00	-0.01	0.05	0.07	0.10	0.17	0.27	0.41	0.57	0.79	1.02	1.28	1.58	1.90
80.0	0.00	-0.02	-0.04	-0.02	0.00	0.01	0.03	0.06	0.11	0.14	0.22	0.28	0.36	0.47	0.63	0.83	1.05	1.30	1.58	1.88	2.22
90.0	0.00	0.02	0.03	0.06	0.17	0.32	0.53	0.57	0.64	0.64	0.71	0.78	0.88	0.97	1.08	1.26	1.47	1.70	1.96	2.25	2.57
100.0	0.00	0.06	0.11	0.16	0.20	0.25	0.21	0.18	0.17	0.18	0.22	0.26	0.34	0.44	0.59	0.77	0.92	1.12	1.30	1.54	1.75
110.0	0.00	0.08	0.13	0.15	0.19	0.18	0.17	0.16	0.16	0.18	0.20	0.22	0.26	0.33	0.44	0.57	0.72	0.87	1.06	1.26	1.48
120.0	0.00	0.10	0.07	0.03	0.01	-0.08	-0.10	-0.10	-0.13	-0.12	-0.12	-0.11	-0.06	0.01	0.09	0.20	0.34	0.48	0.63	0.81	1.00
130.0	0.00	0.03	0.04	0.06	0.08	0.08	0.06	0.05	0.05	0.04	0.05	0.10	0.15	0.23	0.32	0.47	0.62	0.74	0.85	1.05	1.22
140.0	0.00	0.05	0.08	0.09	0.09	0.09	0.10	0.02	-0.06	-0.06	-0.04	0.01	0.07	0.15	0.28	0.41	0.56	0.73	0.94	1.08	1.30
150.0	0.00	0.03	0.02	-0.00	-0.04	-0.08	-0.12	-0.17	-0.18	-0.23	-0.26	-0.21	-0.15	-0.06	0.05	0.19	0.39	0.57	0.73	0.95	1.14
160.0	0.00	0.02	0.04	-0.00	-0.05	-0.11	-0.20	-0.26	-0.30	-0.32	-0.33	-0.24	-0.18	-0.11	0.00	0.11	0.23	0.41	0.62	0.85	1.07
170.0	0.00	0.02	0.03	0.03	-0.01	-0.02	-0.06	-0.10	-0.11	-0.11	-0.09	-0.09	0.03	0.10	0.19	0.36	0.28	0.47	0.67	0.89	1.13
180.0	0.00	-0.01	-0.01	-0.02	-0.06	-0.11	-0.16	-0.20	-0.23	-0.23	-0.22	-0.22	-0.15	-0.08	0.02	-0.04	0.07	0.24	0.42	0.61	0.82
190.0	0.00	0.00	-0.01	-0.05	-0.12	-0.31	-0.51	-0.56	-0.61	-0.67	-0.68	-0.67	-0.64	-0.60	-0.51	-0.45	-0.37	-0.25	-0.11	0.06	0.23
200.0	0.00	-0.01	-0.03	-0.04	-0.28	-0.41	-0.46	-0.53	-0.59	-0.70	-0.75	-0.75	-0.73	-0.70	-0.67	-0.61	-0.54	-0.46	-0.38	-0.28	-0.16
210.0	0.00	0.00	-0.02	-0.05	-0.09	-0.16	-0.23	-0.31	-0.38	-0.42	-0.45	-0.47	-0.48	-0.42	-0.38	-0.38	-0.40	-0.32	-0.23	-0.12	-0.01
220.0	0.00	0.04	0.07	0.07	0.00	-0.04	-0.09	-0.16	-0.19	-0.22	-0.26	-0.26	-0.20	-0.14	-0.12	-0.04	0.06	0.19	0.36	0.37	0.39
230.0	0.00	0.03	0.05	0.04	-0.00	-0.06	-0.10	-0.17	-0.23	-0.27	-0.30	-0.33	-0.34	-0.25	-0.18	-0.13	-0.01	0.09	0.23	0.42	0.52
240.0	0.00	0.01	0.03	0.00	-0.03	-0.08	-0.15	-0.27	-0.33	-0.36	-0.39	-0.42	-0.40	-0.33	-0.28	-0.20	-0.07	0.11	0.31	0.56	0.60
250.0	0.00	0.02	-0.02	-0.08	-0.12	-0.15	-0.19	-0.25	-0.29	-0.30	-0.32	-0.34	-0.32	-0.27	-0.19	-0.06	0.08	0.25	0.44	0.65	0.87
260.0	0.00	0.01	-0.01	0.03	0.03	-0.01	-0.07	-0.19	-0.29	-0.29	-0.27	-0.26	-0.21	-0.12	-0.01	0.11	0.30	0.45	0.61	0.83	1.06
270.0	0.00	-0.01	-0.02	-0.03	-0.05	-0.03	-0.06	-0.09	-0.11	-0.10	-0.07	-0.04	0.01	0.09	0.20	0.34	0.49	0.63	0.78	0.96	1.13
280.0	0.00	-0.06	-0.12	-0.18	-0.24	-0.28	-0.32	-0.34	-0.38	-0.40	-0.39	-0.38	-0.31	-0.26	-0.20	-0.07	0.06	0.22	0.39	0.56	0.75
290.0	0.00	-0.07	-0.12	-0.18	-0.24	-0.28	-0.32	-0.35	-0.34	-0.36	-0.35	-0.30	-0.26	-0.21	-0.13	-0.02	0.11	0.28	0.46	0.66	0.86
300.0	0.00	-0.06	-0.16	-0.21	-0.22	-0.28	-0.35	-0.36	-0.36	-0.37	-0.36	-0.31	-0.25	-0.20	-0.10	0.02	0.18	0.35	0.54	0.76	1.01
310.0	0.00	-0.07	-0.13	-0.20	-0.23	-0.26	-0.25	-0.26	-0.16	-0.16	-0.11	-0.06	0.03	0.14	0.24	0.39	0.60	0.81	1.02	1.31	1.63
320.0	0.00	-0.04	-0.07	-0.10	-0.16	-0.24	-0.27	-0.27	-0.25	-0.26	-0.20	-0.14	-0.03	0.05	0.16	0.31	0.48	0.68	0.93	1.20	1.50
330.0	0.00	-0.03	-0.07	-0.12	-0.18	-0.22	-0.22	-0.20	-0.25	-0.30	-0.29	-0.24	-0.18	-0.14	-0.03	0.13	0.32	0.49	0.72	1.01	1.32
340.0	0.00	-0.04	-0.09	-0.15	-0.20	-0.23	-0.30	-0.36	-0.42	-0.43	-0.44	-0.46	-0.42	-0.34	-0.23	-0.11	0.06	0.28	0.53	0.80	1.13
350.0	0.00	-0.06	-0.11	-0.16	-0.23	-0.27	-0.34	-0.38	-0.42	-0.46	-0.51	-0.51	-0.51	-0.47	-0.39	-0.28	-0.10	0.08	0.32	0.60	0.88
360.0	0.00	-0.00	-0.05	-0.15	-0.21	-0.26	-0.33	-0.39	-0.46	-0.52	-0.55	-0.57	-0.55	-0.55	-0.50	-0.40	-0.27	-0.12	0.08	0.30	0.55

6. Geometry

The spacecraft dimensions are described in Figure 4.

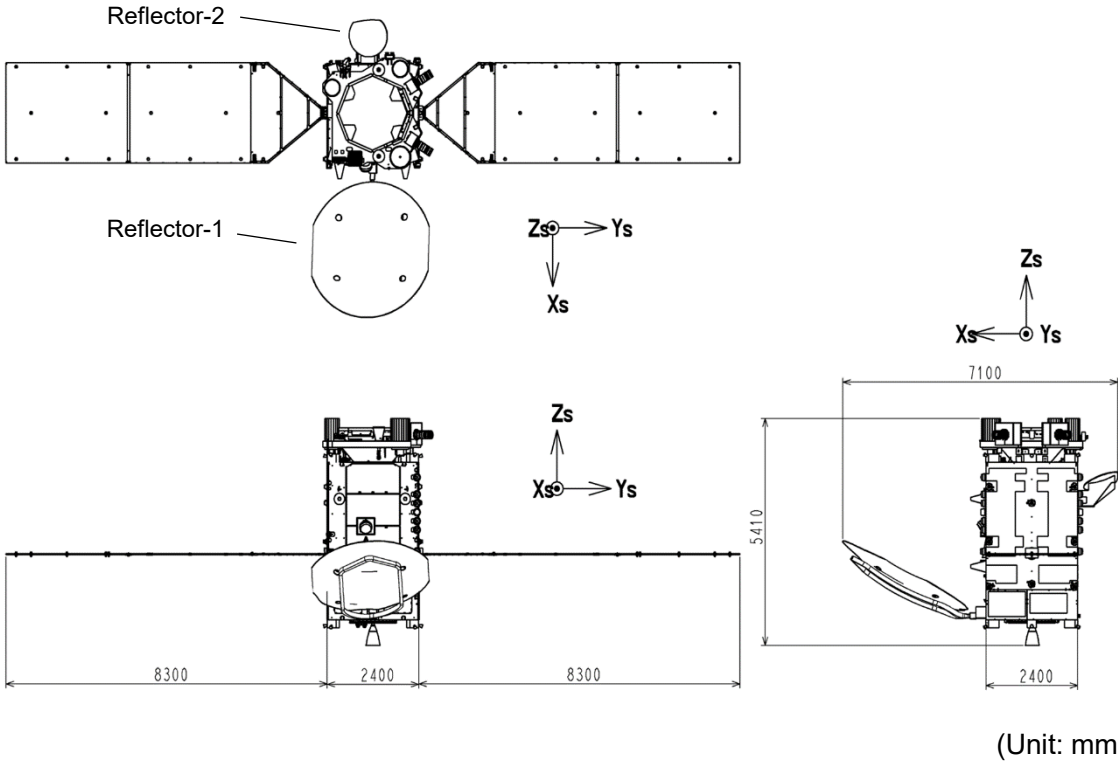

Figure 4 Satellite dimensions

The optical properties of surfaces at BOL are provided in Table 4. The materials whose absorption, specular and diffuse coefficients total less than 1 have transparency.

Table 4 Optical properties^(*1)

Location ^(*2)	Material	Area [m ²]	Absorption	Specular	Diffuse
+X	MLI	10.1	0.926	0.035	0.039
	Reflector-1 (Front) ^(*3)	9.1	0.619	0.005	0.046
	Reflector-1 (Back) ^(*3)	9.1	0.619	0.005	0.046
-X	MLI	10.1	0.926	0.035	0.039
	Reflector-2 (Front) ^(*4)	0.8	0.617	0.023	0.360
	Reflector-2 (Back) ^(*4)	0.8	0.928	0.038	0.034
+Y	MLI	5.0	0.926	0.035	0.039
	Radiator	5.1	0.026	0.954	0.020
	SAP	14.9	0.923	0.068	0.009
-Y	MLI	4.8	0.926	0.035	0.039
	Radiator	5.3	0.026	0.954	0.020
	SAP	14.9	0.923	0.068	0.009
+Z	MLI	3.0	0.926	0.035	0.039
	L-ANT Cover	2.1	0.485	0.459	0.056
	L1S/Sb/L5S-ANT Covers	0.4	0.553	0.100	0.347
-Z	MLI	5.6	0.926	0.035	0.039

*1 : Regarding the acquisition of these data, we received significant support from the assistant professor " Dr. Satoshi Ikari " of University of Tokyo.

*2 : "Location" indicates the face of the satellite body where the components and materials are attached. Note that it doesn't necessarily indicate the direction normal to them.

*3 : Reflector-1 is oriented towards the direction displaced from +Z axis by approximately +5deg and -25deg around +X and +Y axes respectively. Its area corresponds to the area projected along the direction.

*4 : Reflector-2 is oriented towards the direction displaced from +Z axis by approximately +20deg and +15deg around +X and +Y axes respectively. Its area corresponds to the area projected along the direction.

7. Laser Retro Reflector Location

The location of the optical center of the laser retro-reflector array (LRA) with respect to the satellite reference frame is provided in Table 5.

Table 5 Location of LRA optical center

	Coordinates (w.r.t. origin) [mm]		
	X	Y	Z
Optical Center	+1081.8	-460.8	+4373.3

8. Satellite Group Delay

8.1 Satellite Group Delay

N/A

8.2 Differential Code Bias

The differential code bias (DCB) between L1, L2, and L5 signals are provided in Table 7.

Table 7 Differential code bias

Signal	DCB [ns]
L1-L2	4.9
L1-L5	5.3

9. Antenna Transmit Power

Total transmit power is approximately 383W after September 12, 2018 (Before that, it was 550W).

10. GNSS Bibliography

[1] Quasi-Zenith Satellite System Interface Specification Satellite Positioning, Navigation and Timing Service, the Cabinet Office, Government of Japan, 2017.

[2] ILRS SLR Mission Support Request Form

Revision History

Rev.No	Date	Page	Revisions
Org	November 30, 2017		Original
A	May 14, 2018	3 9	Add ftp site of ANTEX file Improve explanation Add optical properties
B	February 6, 2019	8 9	Add pointers to the reflectors. Add explanation on transparency. Add Reflector-2 in Table 4. Rename Reflector to Reflector-1. Add explanations on material's orientation in Table 4 footnotes.
C	January 6, 2021	3 4-7	Add explanation about PCV coordinate system. Azimuth angles are rearranged to be compatible with GNSS standard coordinate system.
D	November 16, 2021	10	Modify total transmit power.
E	March 24, 2022	3	Modify parameters listed in Table 1.
F	March 28, 2025	10	Add a history of total transmit power.