

Quasi-Zenith Satellite System
Interface Specification
Multi-GNSS Advanced Orbit and Clock Augmentation
- Precise Point Positioning
(IS-QZSS-MDC-003)

(August 2024)

Cabinet Office

Disclaimer of Liability

The Cabinet Office, Government of Japan, Quasi-Zenith Satellite System Services Inc. and other service providers of Quasi-Zenith Satellite System make the Interface Specification (IS-QZSS) (“Document”) available to the public to promote the services using Quasi-Zenith Satellite System (“QZSS”) by development of receivers, applications and so on, and also are aiming for high accuracy and convenience with respect to satellite positioning services and message services of QZSS (collectively “Services”). The Services are freely available to any user. However, the receivers and/or applications developed based on this Document may not receive signals or may receive incorrect signals due to no warranty of the Services. You are therefore highly recommended to ensure appropriate measures to avoid accidents such as redundancy, backup and fail-safe, if you develop receivers and/or applications using the Services for the purpose that will possibly give an impact to human life, body and properties. The Services may be suspended or changed without prior notice in accordance with the decision by Government of Japan. This Document and the Services are available subject to the following terms and conditions. You may use this Document only if you agree to such terms and conditions. You shall be deemed to agree such terms and conditions by using this Document.

- (1) With respect to this Document and the information included in this Document, the Cabinet Office, Government of Japan (“CAO”), Quasi-Zenith Satellite System Services Inc. (“QSS”) and other service providers of Quasi-Zenith Satellite System (“Parties”) disclaim all warranties of any kind, express or implied, including but not limited to, the followings:
 - i) warranty of accuracy, completeness, usefulness, and fitness for a particular request or purpose;
 - ii) warranty that this Document and the information included in this Document will not be changed in to the future; and
 - iii) warranty that this Document and the information included in this Document do not infringe any third party’s intellectual property rights.

- (2) With respect to satellite positioning services and message services (collectively “Services”), CAO, QSS and Parties disclaim all warranties of any kind, express or implied, from any cause whether it is related to Quasi-Zenith Satellite System, other outside systems or not, including but not limited to, the followings:
 - i) warranty as to service area, accuracy, availability, continuity, and integrity described in this Document;
 - ii) warranty of usefulness, and fitness for a particular request or purpose; and
 - iii) warranty that the use of Services does not infringe any third party’s intellectual property rights.

- (3) To the extent permitted by applicable laws, CAO, QSS and Parties shall not be responsible and liable for any damages and losses, including but not limited to, direct, indirect, incidental, special or consequential damages, whether under contractual liability, product liability, strict liability, tort liability or otherwise (including intent or negligence), caused by the use of this Document, the information included in this Document and the Services, the inability to use the Services, or the change of this Document and the information included in this Document.

Revision History

Rev.No.	Date	Page	Revisions
001	February 2022	—	—
002	November 2023	2	<ul style="list-style-type: none"> ▪ Update of reference document 2.2(1)(5). ▪ Addition of reference document 2.2(6)~(9).
		6	<ul style="list-style-type: none"> ▪ Satellite types removed because it could be changed according to future development. ▪ Addition of description regarding PRN code assignment. ▪ Service assignment for PRN code 197 is changed from Technoligy Demonstation to CLAS.
		10	<ul style="list-style-type: none"> ▪ Modification of detailed description about Facility ID in 4.2.1(3).
		10,20	<ul style="list-style-type: none"> ▪ Addition of description about augmented navigation message.
		10,37	<ul style="list-style-type: none"> ▪ Addition of usage condition about Alert Flag in 4.2.1(4) and 5.4.1.
		11	<ul style="list-style-type: none"> ▪ Addition the number of data parts that consist the subframe.
		11,13,20	<ul style="list-style-type: none"> ▪ Correction of misprints in 4.2.2.1 and 4.2.2.1(3).
		13,27	<ul style="list-style-type: none"> ▪ Change the Validity Period of Clock Correction in Table 4.2.2-3. ▪ Addition of usage about the use of Validity Period in 4.2.2.1(2). ▪ Change "Nominal Validity Period" to "Validity Period".
		16	<ul style="list-style-type: none"> ▪ Addition of usage about IOD SSR in 4.2.2.1(6).
		17,18,42	<ul style="list-style-type: none"> ▪ Addition of QZSS L1C/B mask definition in Table 4.2.2-8, Table 4.2.2-9 and Table 5.5.3-4.
		18,42	<ul style="list-style-type: none"> ▪ Addition of Galileo E6 and QZSS L6 signal definition in Table 4.2.2-9 and Table 5.5.3-3.
		19	<ul style="list-style-type: none"> ▪ Correction of message size in Figure 4.2.2-3. ▪ Correction of misprint in Table 4.2.2-11.
		27	<ul style="list-style-type: none"> ▪ Addition of usage about URA in 4.2.2.7(1).
27,37	<ul style="list-style-type: none"> ▪ Modification of NULL message in 4.2.2.8 and 5.4.2. 		
36	<ul style="list-style-type: none"> ▪ Modification of the ITRF version in 5.2. 		

Rev.No.	Date	Page	Revisions
		38,40	▪ Addition of description about broadcast parameter selection in 5.5.1.2 and 5.5.2.2.
		46,47	▪ Addition of description of symbol PRN.
		47	▪ Modification of notes.
		48-62	▪ Addition of Correction Information for the Technology Demonstration.
003	August 2024	20	▪ Addition of definition of GNSS IODE
		38	▪ Addition of definition reference point by MADOCA-PPP.
		46	▪ Addition of explanation of the processing regarding Phase Discontinuity Indicator.
		46,48,63	▪ Change term to "phase wind-up"
		63	▪ Addition of recommendation about using STEC correction data.

"TBD" is an abbreviation for "To be determined." Those items marked "TBD" have not yet been determined but will be determined in the future.

Table of Contents

1. Scope.....	1
2. Relevant Documents and Definition of Terms.....	2
2.1 Applicable Documents.....	2
2.2 Reference Documents.....	2
2.3 Terms and Definitions.....	4
2.4 Abbreviations.....	5
3. Signal Specifications.....	7
4. Message Specifications.....	8
4.1 Message Structure.....	8
4.1.1 General.....	8
4.1.2 Timing.....	9
4.2 Message contents.....	10
4.2.1 Header Part.....	10
4.2.2 Data Part.....	12
4.2.2.1 General.....	12
4.2.2.2 Sub Type1 - Compact SSR Mask Message.....	15
4.2.2.3 Sub Type2 - Compact SSR GNSS Orbit Correction Message.....	20
4.2.2.4 Sub Type3 - Compact SSR GNSS Clock Correction Message.....	22
4.2.2.5 Sub Type4 - Compact SSR GNSS Satellite Code Bias Message.....	23
4.2.2.6 Sub Type5 - Compact SSR GNSS Satellite Phase Bias Message.....	25
4.2.2.7 Sub Type7 - Compact SSR GNSS URA Message.....	27
4.2.2.8 Null Message.....	28
4.3 Transmission Pattern.....	29
4.4 FEC Encoded Algorithm.....	33
4.4.1 Reed-Solomon Coding/Decoding Algorithm for L6 Navigation Message.....	34
5. User Algorithms.....	37
5.1 Time System.....	37
5.2 Coordinate System.....	37
5.3 Constants.....	38
5.3.1 Speed of Light.....	38
5.3.2 Circular Constant.....	38
5.4 Integrity.....	38
5.4.1 Alert Flag.....	38
5.4.2 Null Message.....	38
5.5 Calculation Algorithms for Compact SSR.....	39
5.5.1 Calculation of GNSS Clock Correction.....	40
5.5.1.1 Parameter.....	40
5.5.1.2 Algorithm.....	40
5.5.2 Calculation of GNSS Orbit Correction.....	41
5.5.2.1 Parameters.....	41

5.5.2.2 Algorithm	42
5.5.3 Calculation of GNSS Code/Phase Bias.....	43
5.5.3.1 Applicable Signals of Code/Phase Bias	43
5.5.3.2 Parameters.....	46
5.5.3.3 Algorithm.....	46
5.5.4 (Reference) User dependent errors	47
5.5.5 (Reference) Observation Equations	48
5.5.5.1 Parameter	48
5.5.5.2 Algorithm.....	49
6. Correction Information for the Technology Demonstration.....	50
6.1 General.....	50
6.2 Message Structure.....	51
6.3 Message contents	51
6.3.1 Header Part	51
6.3.2 Data Part	51
6.3.2.1 General.....	51
6.3.2.2 MT1 - STEC Coverage Message	53
6.3.2.3 MT2 - STEC Correction Message	56
6.4 Transmission Pattern.....	60
6.5 User Algorithm	61
6.5.1 Calculation of Ionosphere Slant Delay Correction	61
6.5.1.1 Parameter	61
6.5.1.2 Algorithm.....	62
6.5.2 (Reference) Observation Equations	63
6.5.2.1 Parameter	63
6.5.2.2 Algorithm.....	64

1. Scope

This interface specification document describes the interface specification between the Quasi-Zenith Satellite System (QZSS) and users of the Multi-GNSS Advanced Orbit and Clock Augmentation-Precise Point Positioning Service (MADOCA-PPP). The interface specification includes the message specification and user algorithm. The signal characteristic shall be referred to Section 3 of the applicable document (4) IS-QZSS-L6, Quasi-Zenith Satellite System Interface Specification Centimeter Level Augmentation Service.

The Service introduction and the system introduction are described in the applicable document (1) PS-QZSS, Quasi-Zenith Satellite System Performance Standard.

2. Relevant Documents and Definition of Terms

2.1 Applicable Documents

The cited parts of the following documents are recognized as being part of this document. This document may be updated when these applicable documents are updated.

- (1) PS-QZSS, Quasi-Zenith Satellite System Performance Standard.
- (2) RTCM STANDARD 10403.3 DIFFERENTIAL GNSS (GLOBAL NAVIGATION SATELLITE SYSTEMS) SERVICE –VERSION 3, RTCM SPECIAL COMMITTEE NO.104, 7-OCT-2016.
- (3) Mitsubishi Electric Corporation, Specification of Compact SSR Messages for Satellite Based Augmentation Service, Version 08, 17-SEP-2019, DOI:10.13140/RG.2.2.10749.49129.
- (4) IS-QZSS-L6, Quasi-Zenith Satellite System Interface Specification Centimeter Level Augmentation Service.

2.2 Reference Documents

The following documents are referred on the creation of this document. This document might be updated when these reference documents are updated.

- (1) Global Positioning Systems Directorate Systems Engineering & Integration Interface Specification IS-GPS-200, Navstar GPS Space Segment/Navigation User Interfaces
- (2) Wu, J.T., S.C. Wu, G.A. Hajj, W.I. Bertiger, S.M. Lichten., Effects of Antenna Orientation on GPS Carrier Phase, Manuscripta Geodaetica, 18, 91-98, 1993.
- (3) G. Petit and B. Luzum (eds.), IERS Technical Note No.36, IERS Conventions (2010), 2010.
- (4) J. Kouba, A Guide to using International GNSS Service (IGS) products, May 2009.
- (5) IS-QZSS-SAS, Quasi-Zenith Satellite System Interface Specification Signal Authentication Service.
- (6) IS-QZSS-PNT, Quasi-Zenith Satellite System Interface Specification Satellite Positioning, Navigation and Timing Service
- (7) Global Navigation Satellite System GLONASS, Interface Control Document, Navigational radiosignal In bands L1, L2.
- (8) European GNSS (Galileo) Open Service Signal In Space Interface Control Document.
- (9) BeiDou navigation satellite system signal in space interface control document open service signal, China Satellite Navigation office.

- (10) Rothacher, M., Schmid, R., 2010. ANTEX: the antenna exchange format, Version 1.4, 15 Sep 2010. URL <https://files.igs.org/pub/station/general/antex14.txt>
- (11) Montenbruck O, Schmid R, Mercier F, Steigenberger P, Noll C, Fatkulin R, Kogure S, Ganeshan AS, GNSS satellite geometry and attitude models. Adv Space Res 56 (2015): 1015-1029

2.3 Terms and Definitions

Terms	Definitions
alert flag	See Section 5.4.1 If the service stops due to an error occurring in the ground or satellite system, an alert flag is notified to the user that the service is not available.
L6 message	See Section 4.2.1 A message transmitted by L6 signal, consisting of a 49-bit header, a 1695-bit data part, and a 256-bit Reed-Solomon code. The message is transmitted in one second.
frame	See Figure 4.2.2-1 Multiple subframe. The number of subframe depends on an update interval of each Compact SSR message.
subframe	See Figure 4.2.2-1 Successive data parts of L6 message from 1 to 0 of multiple Message Indicator
Compact SSR message	See Section 4.2.2 Bandwidth efficient State Space Representation (SSR) format message for Precise Point Positioning -Real Time Kinematic (PPP-RTK) service defined as a proprietary message in the applicable document (2). Compact SSR messages are included in the data part of L6 message.
Technology Demonstration (ionospheric correction)	Wide area ionospheric corrections are provided for the Asia and Oceania region as a Technology Demonstration of MADOCA-PPP. Technology Demonstration (ionospheric correction) messages are transmitted as L6D messages.
Quasi-Zenith Satellite Navigation Message Authentication	Quasi-Zenith Satellite Navigation Message Authentication is the message data for the Navigation Message Authentication generated by the QZSS.

2.4 Abbreviations

-A-

-B-

-C-

CDMA	Code Division Multiple Access
CLAS	Centimeter Level Augmentation Service
CSK	Code Shift Keying
CNAV	Civil Navigation
CNAV-2	L1C Navigation Message
CPC	Carrier Phase Correction

-D-

-E-

ECEF	Earth Centered Earth Fixed
------	----------------------------

-F-

FDMA	Frequency Division Multiple Access
FEC	Forward Error Correction

-G-

GEO	Geostationary Orbits
GLONASS	Global Navigation Satellite System
GNSS	Global Navigation Satellite System
GPS	Global Positioning System
GPST	GPS Time

-H-

-I-

ID	Identification
IERS	International Earth Rotation and Reference Systems Service
IOD	Issue Of Data
IODE	Issue Of Data, Ephemeris
ISB	Inter System Bias
ITRF	International Terrestrial Reference Frame
I/NAV	Integrity Navigation Message

-J-

-K-

-L-

LNAV	Legacy Navigation
LSB	Least Significant Bit

-M-

MADOCA-PPP	Multi-GNSS Advanced Orbit Clock Augmentation – Precise Point Positioning
MSB	Most Significant Bit
MT	Message Type

-N-

-O-

-P-

PCO	Phase Center Offset
PCV	Phase Center Variation
PPP	Precise Point Positioning
PRC	Pseudo Range Correction
PRN	Pseudo-Random Noise

-Q-

QZNMA	Quasi-Zenith Satellite Navigation Message Authentication
QZO	Quasi-Zenith Orbits
QZS	Quasi-Zenith Satellite
QZSS	Quasi-Zenith Satellite System
QZSST	QZSS Time

-R-

R-S	Reed-Solomon
RSC	Reed-Solomon code
RTCM	Radio Technical Commission for Maritime Services

-S-

SBAS	Satellite Based Augmentation System
SF	Subframe
SSR	State Space Representation
ST	Sub Type
SV	Space Vehicle

-T-

TAI	International Atomic Time
TBD	To Be Determined
TTF	Time To First Fix

-U-

URA	User Range Accuracy
-----	---------------------

-V-

-W-

-X-

-Y-

-Z-

3. Signal Specifications

MADOCA-PPP data are transmitted as L6D or L6E messages from the QZSS satellites described in Table 3-1. PRN code assignment including non-standard codes could be updated according to the future development. Users shall confirm the contents of the message based on the PRN code and L6 message type ID in the Header Part of the message. The signal characteristic of L6 shall be referred to as Signal Characteristic in the applicable document (4) .

Table 3-1 Service assignment of L6 messages depending on the satellite (*1)

L6D (L6 code 1)		L6E (L6 code 2)		Remarks
PRN	L6D Message	PRN	L6E Message	
193	CLAS	203	—	—
194	CLAS	204	MADOCA-PPP and QZNMA	—
195	CLAS	205	MADOCA-PPP and QZNMA	—
196	CLAS	206	MADOCA-PPP and QZNMA	—
197	CLAS	207	MADOCA-PPP and QZNMA	—
198	—	208	—	Used as a non-standard code (*2)
199	CLAS	209	MADOCA-PPP and QZNMA	—
200	Technology Demonstration (ionospheric correction)	210	MADOCA-PPP and QZNMA	—
201	Technology Demonstration (ionospheric correction)	211	MADOCA-PPP and QZNMA	—
202	—	212	—	Used as a non-standard code (*2)

(*1)

Technology Demonstration (ionospheric correction):

Wide area ionospheric corrections defined in section 6. are provided for the Asia and Oceania region as a Technology demonstration of MADOCA-PPP.

CLAS:

See applicable document (4) for the message specification of CLAS.

QZNMA:

See reference document (5) for the message specification of QZNMA.

(*2) There is a possibility that the code is used for services as MADOCA-PPP etc. in the future.

4. Message Specifications

4.1 Message Structure

4.1.1 General

The L6 message signal structure is shown in Figure 4.1.1-1. Each message has a length of 2000 bits, consisting of a 49-bit header, a 1695-bit data section, and a 256-bit Reed-Solomon code. The transmission of each L6 message takes one second.

The header of the L6 message starts from bit 1 (MSB), followed by the data part (1695-bit), which is transmitted from bit 50. The Reed-Solomon Code is transmitted from bit 1745, after the data part.

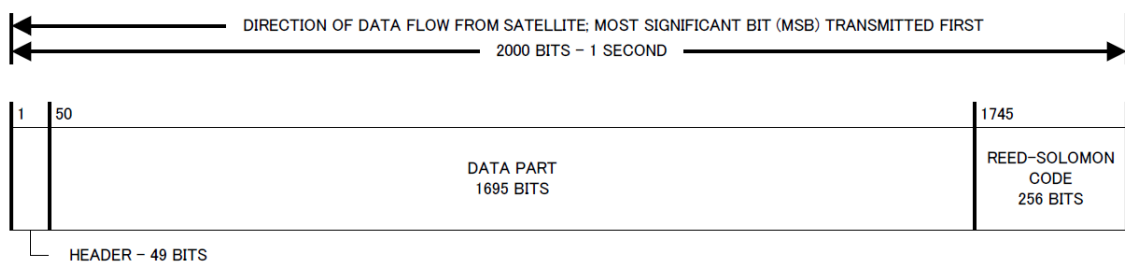

Figure 4.1.1-1 L6 Message Structure

The content of the data part of the L6 message can be identified by the Vender ID, which is the first 3-bit header of the L6 message type ID. (See Table 4.2.1-2)

In the L6D message, each satellite is assigned one of the services of either Technology Demonstration (ionospheric correction) or CLAS. Technology Demonstration (ionospheric correction) and CLAS in L6D messages shall not be intermixed. See Table 3-1 for the assignment of the L6 messages for each satellite.

Messages for MADOCA-PPP and QZNMA are broadcast time-divisionally from the satellites. Of the 30 messages sent in 30 seconds, 6 messages are allocated for QZNMA. See Figure 4.1.1-2 for the assignment for MADOCA-PPP and QZNMA.

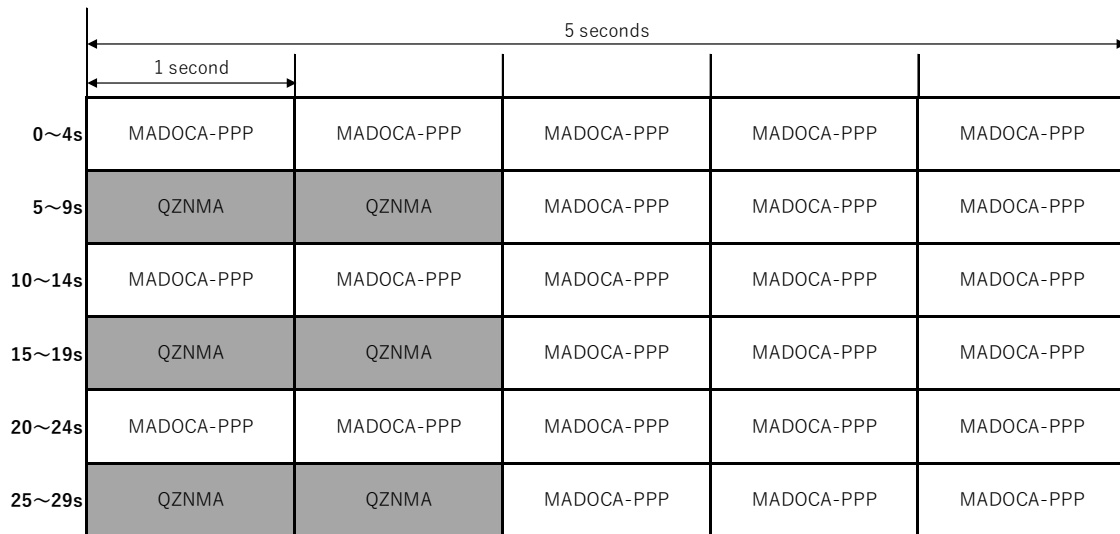

Figure 4.1.1-2 Service assignment for the L6E message

4.1.2 Timing

(1) Transmission Pattern

The nominal transmission pattern for MADOCA-PPP is specified in Section 4.3.

The transmission pattern of the data part in the L6 message may differ between satellites. Therefore, the user algorithm cannot assume any specific transmission pattern.

(2) Transmission Timing

Each satellite might transmit L6 messages with different contents among satellites. See Section 4.2.2 (3) for the treatment of the L6 message for MADOCA-PPP.

4.2 Message contents

4.2.1 Header Part

The header of the L6 message is shown in Figure 4.2.1-1. The header part has a length of 49-bit consisting of a 32-bit preamble, an 8-bit PRN, an 8-bit L6 message type ID and a 1-bit alert flag.

Table 4.2.1-1 defines the header parameters.

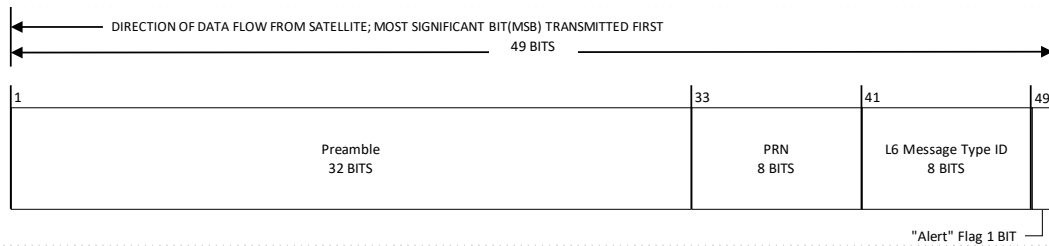

Figure 4.2.1-1 Header of L6 message

Table 4.2.1-1 Definitions of header parameters

DF Name	DF Range	BIT	LSB	DF Unit	Note
Preamble	-	32	-	-	
PRN	-	8	-	-	
L6 Message Type ID	-	8	-	-	See Table 4.2.1-3
"Alert" Flag	-	1	-	-	

(1) Preamble

At the beginning of each message is a 32-bit preamble. The value of the preamble is “0001101011001111111110000011101”^(B).

(2) PRN

Each message has an 8-bit PRN number immediately after the preamble. The PRN number is the PRN number of the satellite transmitting that message.

(3) L6 Message Type ID

The initial 3-bit of the L6 message type ID is Vendor ID. Vendor ID is the identifier to identify the service of the L6 message, which is defined in Table 4.2.1-2.

The L6 message type ID of MADOCA-PPP is defined in Table 4.2.1-3. The initial 3-bit of the vendor ID is "010"_(B), which indicates MADOCA-PPP. The following 2-bit is the identifier indicating the message generation facilities. The following 1-bit is the identifier that indicates whether the transmitted correction data are Clock/Ephemeris corrections or ionospheric corrections. The following 1-bit is the identifier that indicates the applicable navigation messages of Orbit and Clock Corrections.

The last 1-bit is the indicator for the subframe header. If the value of this indicator is "1", the message is the start of a subframe.

The LSB 1bit of Message Generation Facility ID is indicating the stream that generate MADOCA-PPP correction data. The L6 message with Message Generation Facility ID "00"_(B) or "10"_(B) are correction data from the same stream, similarly "01"_(B) or "11"_(B) are same. MADOCA-PPP user shall use L6 messages that the Vendor ID is "010"_(B) and the LSB 1bit of Message Generation Facility ID are the same, to decode L6 messages.

Table 4.2.1-2 Vendor ID (MSB 3bits) in L6 message type ID

Vendor ID (3bits)	Service Name	Note
"101" _(B)	CLAS	Broadcast L6D message only See applicable document (4)
"010" _(B)	MADOCA-PPP	Broadcast L6D and L6E message
"011" _(B)	QZNMA	Broadcast L6E message only See reference document (5)
others	Reserved	—

Table 4.2.1-3 L6 message type ID (MADOCA-PPP)

Bit Field	Data Name	Note
7-5	Vendor ID	See Table 4.2.1-2
4-3	Message Generation Facility ID	"00" _(B) , "01" _(B) : Hitachi-Ota "10" _(B) , "11" _(B) : Kobe
2	Correction Service ID	"0" _(B) : Clock/Ephemeris Corrections "1" _(B) : Ionospheric Corrections
1	Applicable navigation message extension	The flag that indicates the applicable GPS/QZSS messages of Orbit and Clock Correction (See Table 4.2.2-12) "0" _(B) : LNAV "1" _(B) : CNAV/CNAV-2
0	Subframe indicator	"1" _(B) : first data part of a subframe "0" _(B) : others

(4) Alert Flag

Each message has a 1-bit alert flag immediately following the L6 Message Type ID. The Alert Flag indicates the health status of L6 signal and message. User shall also refer to Section 5.4.1 for alert flag handling.

4.2.2 Data Part

4.2.2.1 General

The nominal sequence of the L6E message consists of 12 subframes. Figure 4.2.2-1 shows the structure of the L6E message, frame, and subframe. Subframe 1,4,5,8,9,12 are assigned to MADOCA-PPP, and subframe 2,3,6,7,10,11 are assigned to QZNMA. The MADOCA-PPP subframe consists of 3 or 5 successive data parts. The QZNMA subframe consists of one data part.

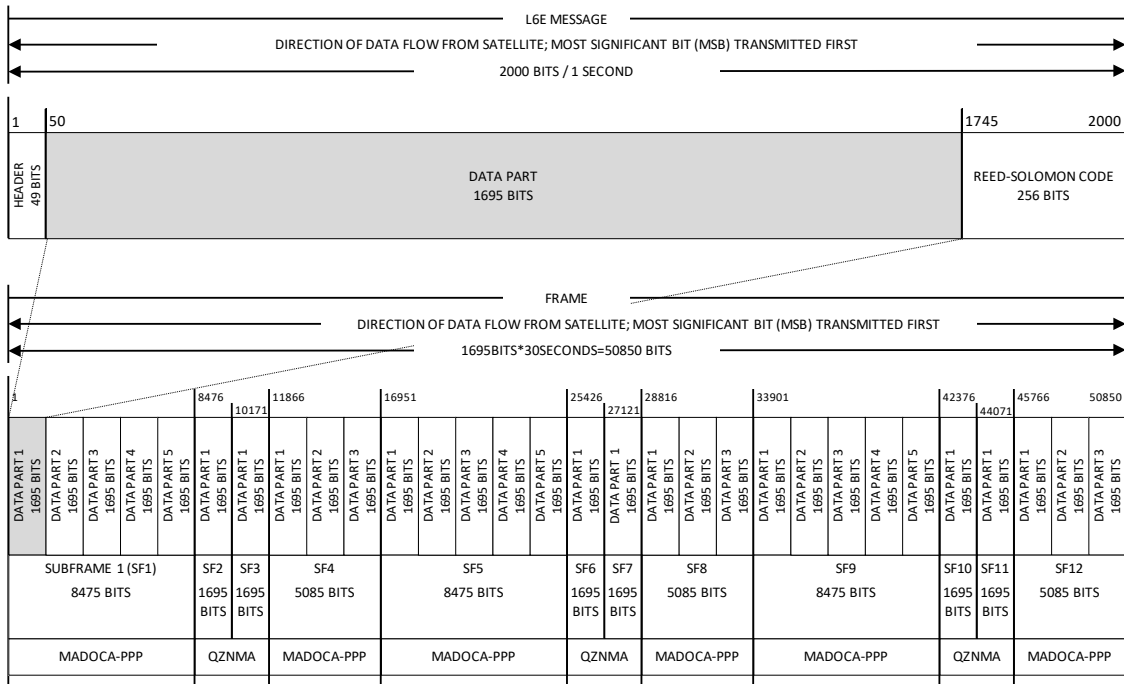

Figure 4.2.2-1 Structure of L6E message, frame, and subframe

The data part of MADOCA-PPP includes any sub type of multiple messages of MT 4073 “Compact SSR” (Table 4.2.2-1), as defined in the applicable document (3). The data in each message is given in state space representation (SSR) form, as standardized in the applicable document (2). The correction in SSR form can be applied to precise point positioning.

The sub type 1-7 structures are transmitted from the beginning of each subframe in a given order which defined in section 4.3 . For each last data part of the subframe, there is the reserved field which are filled with zeros.

No sub type message is transmitted through successive subframes.

Table 4.2.2-1 List of MADOCA-PPP Messages

RTCM Message Type	Sub Type	Message Name	No. of Bit ^{(*1), (*2)}	Section No.
4073	1	Compact SSR Mask	$49 + (61 + N_{\text{cell}}) \times N_{\text{sys}}$	4.2.2.2
4073	2	Compact SSR GNSS Orbit Correction	$37 + (51 \text{ or } 49) \times N_{\text{sat}}$	4.2.2.3
4073	3	Compact SSR GNSS Clock Correction	$37 + 15 \times N_{\text{sat}}$	4.2.2.4
4073	4	Compact SSR GNSS Satellite Code Bias	$37 + 11 \times N_{\text{sig(sys)}} \times N_{\text{sat(sys)}}$	4.2.2.5
4073	5	Compact SSR GNSS Phase Bias	$37 + 17 \times N_{\text{sig(sys)}} \times N_{\text{sat(sys)}}$	4.2.2.6
4073	7	Compact SSR GNSS URA	$37 + 6 \times N_{\text{sat}}$	4.2.2.7

(*1) N_{cell} = No. of Cell Mask of each GNSS, N_{sat} = No. of augmented satellite, N_{sys} = No. of augmented GNSS

N_{sig} = No. of augmented signal, $N_{\text{sat(sys)}}$ = No. of augmented satellite of each GNSS,

$N_{\text{sig(sys)}}$ = No. of augmented signal of each GNSS

(*2) The sizes of N_{cell} , $N_{\text{sig(sys)}}$ and $N_{\text{sat(sys)}}$ depend on each GNSS.

(1) Update Interval

Table 4.2.2-2 shows the nominal update interval for each message. Note that the user algorithm cannot rely on any specific transmission pattern since it may be changed in the future for reasons of performance improvement.

Table 4.2.2-2 Nominal Update Interval

Message Name	Message Type ID, Sub Type ID (*1)	Nominal Update Interval [s]
Compact SSR Mask	MT4073,1	30
Compact SSR GNSS Orbit Correction	MT4073,2	30
Compact SSR GNSS Clock Correction	MT4073,3	5
Compact SSR GNSS Satellite Code Bias	MT4073,4	30
Compact SSR GNSS Satellite Phase Bias	MT4073,5	30
Compact SSR GNSS URA	MT4073,7	30
Null Message	(N/A)	(N/A)

(*1) Sub type ID is compliant with Compact SSR (Message Type 4073) which is defined as a proprietary message in the applicable document (3) that is compatible with the applicable document (2) RTCM STANDARD 10403.3. Section 4.2.2 provides more information about the message format for each sub type.

(2) Validity Period

Each message has a validity period based on each characteristic. Table 4.2.2-3 shows Validity Period of each message. Origin of the validity interval is exact second of QZSST that is sent in the header part of messages that contains the information (refer to the data field “GPS Epoch Time 1s” and “GNSS Hourly Epoch Time 1s”).

Table 4.2.2-3 Validity Period

Message Name	Message Type ID, Sub Type ID	Validity Period [s]
Compact SSR Mask	MT4073,1	(*1)
Compact SSR GNSS Orbit Correction	MT4073,2	60
Compact SSR GNSS Clock Correction	MT4073,3	60
Compact SSR GNSS Satellite Code Bias	MT4073,4	60
Compact SSR GNSS Satellite Phase Bias	MT4073,5	60
Compact SSR GNSS URA	MT4073,7	60
Null Message	(N/A)	(N/A)

(*1) Validity interval of Compact SSR Mask is described in 4.2.2.2 .

The epoch of each correction data might be different. MADOCA-PPP user can use correction data sets with different Epoch that do not exceed validity period.

The correction data that exceeded the validity period can be used as an own risk, however note that the quality of data is degraded.

(3) Relationship among L6 Messages Transmitted by Each Satellite

The contents of L6 messages transmitted by each QZSS satellite might be different. In this case, the SSR Mask of Sub Type 1 shall be applied for Sub Type 2, 3, 4, 5 and 7 transmitted by the same satellite. Correction data transmitted by different QZSS satellites can be merged and utilized, even if Message Generation Facility ID is different.

4.2.2.2 Sub Type1 - Compact SSR Mask Message

The sub type 1 message structure is shown in Figure 4.2.2-2. The message header and GNSS specific part are defined in Table 4.2.2-4 and Table 4.2.2-5, respectively.

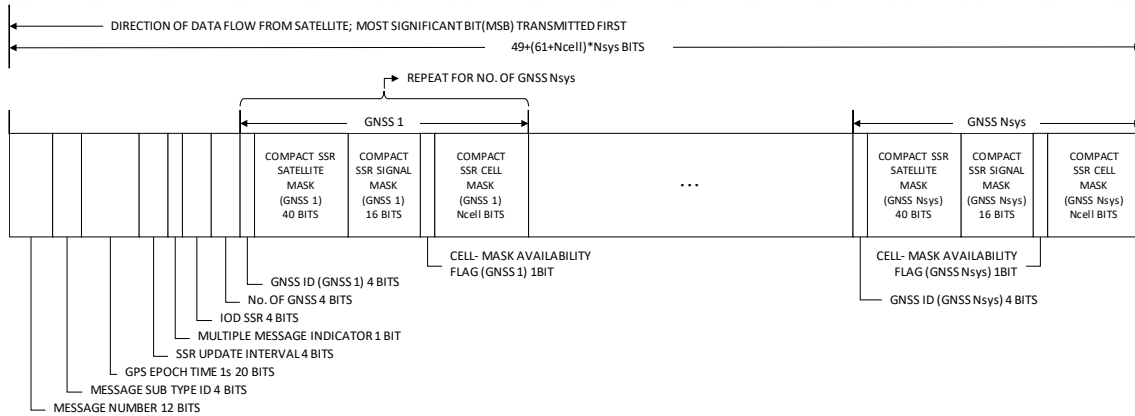

Figure 4.2.2-2 Compact SSR Mask Message structure

Table 4.2.2-4 Contents of message header, Compact SSR Mask Message

DF Name	DF Range	BIT	LSB	DF Unit	Note
Message Number	0-4095	12	-	-	4073
Message Sub Type ID	0-15	4	-	-	1
GPS Epoch Time 1s	0-604799	20	1	s	
SSR Update Interval	0-15	4	1	-	
Multiple Message Indicator	0-1	1	-	-	
IOD SSR	0-15	4	1	-	
No. of GNSS	0-15	4	1	-	

Table 4.2.2-5 Contents of GNSS-specific part of Compact SSR Mask Message

DF Name	DF Range	BIT	LSB	DF Unit	Note
GNSS ID 1	0-15	4	-	-	
Compact SSR Satellite mask 1	-	40	-	-	
Compact SSR Signal mask 1	-	16	-	-	
Cell-mask Availability Flag	0-1	1	-	-	
Compact SSR Cell mask 1	-	N_{cell}	-	-	
~					
GNSS ID N_{sys}	0-15	4	-	-	
Compact SSR Satellite mask N_{sys}	-	40	-	-	
Compact SSR Signal mask N_{sys}	-	16	-	-	
Cell-mask Availability Flag	0-1	1	-	-	
Compact SSR Cell mask N_{sys}	-	N_{cell}	-	-	

(1) Message Number

The message number is defined in the applicable document (2). Until the standardization of Compact SSR has been completed, 4073 is used as the proprietary message.

(2) Message Sub Type ID

The message sub type ID is defined in the Compact SSR specification (applicable document (3)).

(3) GPS Epoch Time 1s

Seconds since the beginning of the GPS week. The data is defined in QZSST.

(4) SSR Update Interval

The SSR update intervals for all the SSR parameters start at time 00:00:00 of the QZSST time frame. The supported SSR update intervals are listed in Table 4.2.2-6.

Table 4.2.2-6 SSR update interval

SSR Update Interval	Update Interval
0	1 s
1	2 s
2	5 s
3	10 s
4	15 s
5	30 s
6	60 s
7	120 s
8	240 s
9	300 s
10	600 s
11	900 s
12	1800 s
13	3600 s
14	7200 s
15	10800 s

(5) Multiple Message Indicator

Indicator for transmitting message with the same message number, message sub type ID, and epoch time. "0": last message of a sequence, "1": multiple message transmitted.

(6) IOD SSR

A change of issue of data SSR is used to indicate a change in the SSR generating configuration. The IOD SSR is counted up from 0₍₁₀₎. When the Compact SSR satellite mask, Compact SSR signal mask, or Compact SSR cell mask have been changed, the IOD SSR is counted up. MADOCA-PPP user should apply Compact SSR Mask with same IOD SSR, to decode sub-type 2, 3, 4, 5 and 7.

(7) No. of GNSS

Number of augmented GNSS.

(8) GNSS ID

Indicator for specifying the GNSS. Table 4.2.2-7 lists the reciprocal relationship between the GNSS ID and GNSS.

Table 4.2.2-7 GNSS ID

GNSS ID	GNSS
0	GPS
1	GLONASS
2	Galileo
3	BeiDou
4	QZSS
5	SBAS
6-9	Reserved

(9) Compact SSR Satellite mask

The sequence of bits, which specifies those GNSS satellites for which data is augmented in this message. The most significant bit (MSB), or the first encoded bit corresponds to that GNSS satellite for which ID = 1, the second bit corresponds to a GNSS satellite for which ID = 2, etc. The least significant bit (LSB), or the last-encoded bit corresponds to a GNSS satellite with ID = 40. For QZSS, a satellite with ID = 1-10 is PRN193-202. Table 4.2.2-8 lists the reciprocal relationships between the Compact SSR satellite mask and GNSS.

Table 4.2.2-8 Compact SSR satellite mask

Compact SSR Satellite Mask	0 (MSB)	1	2	3	4	5	6	7	8	9	10	11	12	13	14
GPS	1	2	3	4	5	6	7	8	9	10	11	12	13	14	15
GLONASS	1	2	3	4	5	6	7	8	9	10	11	12	13	14	15
Galileo	1	2	3	4	5	6	7	8	9	10	11	12	13	14	15
BeiDou	1	2	3	4	5	6	7	8	9	10	11	12	13	14	15
QZSS*	193	194	195	196 203	197 204	198	199	200 205	201 206	202	Reserved				

Compact SSR Satellite Mask	15	16	17	18	19	20	21	22	23	24	25	26	27	28	29
GPS	16	17	18	19	20	21	22	23	24	25	26	27	28	29	30
GLONASS	16	17	18	19	20	21	22	23	24	Reserved					
Galileo	16	17	18	19	20	21	22	23	24	25	26	27	28	29	30
BeiDou	16	17	18	19	20	21	22	23	24	25	26	27	28	29	30
QZSS	Reserved														

Compact SSR Satellite Mask	30	31	32	33	34	35	36	37	38	39 (LSB)
GPS	31	32	33	34	35	36	37	38	39	40
GLONASS	Reserved									
Galileo	31	32	33	34	35	36	37	Reserved		
BeiDou	31	32	33	34	35	36	37	38	39	40
QZSS	Reserved									

* PRN number for QZSS is used to express which QZSS is augmented for convenience. PRN 203-206 is described alongside because some satellites transmit L1C/B with PRN 203-206 while they transmit L1C, L2C, and L5 with PRN 193-202.

(10) Compact SSR Signal mask

The sequence of bits which defines the selected signals for correction messages defined for each GNSS, as listed in Table 4.2.2-9.

Table 4.2.2-9 Compact SSR signal mask

Compact SSR Signal mask	GPS	GLONASS	Galileo	BeiDou	QZSS	SBAS
0	L1 C/A	G1 C/A	E1 B I/NAV OS/CS/SoL	B1 I	L1 C/A	L1 C/A
1	L1 P	G1 P	E1 C no data	B1 Q	L1 L1C(D)	L5 I
2	L1 Z-tracking	G2 C/A	E1 B+C	B1 I+Q	L1 L1C(P)	L5 Q
3	L1 L1C(D)	G2 P	E5a I F/NAV OS	B3 I	L1 L1C(D+P)	L5 I+Q
4	L1 L1C(P)	G1a(D)	E5a Q no data	B3 Q	L2 L2C(M)	
5	L1 L1C(D+P)	G1a(P)	E5a I+Q	B3 I+Q	L2 L2C(L)	
6	L2 L2C(M)	G1a(D+P)	E5b I I/NAV OS/CS/SoL	B2 I	L2 L2C(M+L)	
7	L2 L2C(L)	G2a(D)	E5b Q no data	B2 Q	L5 I	
8	L2 L2C(M+L)	G2a(P)	E5b I+Q	B2 I+Q	L5 Q	
9	L2 P	G2a(D+P)	E5 I		L5 I+Q	
10	L2 Z-tracking	G3 I	E5 Q		L6D	
11	L5 I	G3 Q	E5 I+Q		L6P	
12	L5 Q	G3 I+Q	E6 B		L6E	
13	L5 I+Q		E6 C		L1 C/B	
14						
15						

(11) Cell-mask Availability Flag

If the flag set to "1"_(B), the cell-mask is included.

(12) Compact SSR Cell Mask

The sequence of bits, which specifies those signals for which data is available in this message for each satellite. Note that the cell mask is not included if the cell-mask availability flag is set to zero. In this case, all of the signals included in the signal mask are selected for all the selected satellites.

4.2.2.3 Sub Type2 - Compact SSR GNSS Orbit Correction Message

The sub type 2 message structure is shown in Figure 4.2.2-3. The message header and satellite-specific part are defined in Table 4.2.2-10 and Table 4.2.2-11, respectively.

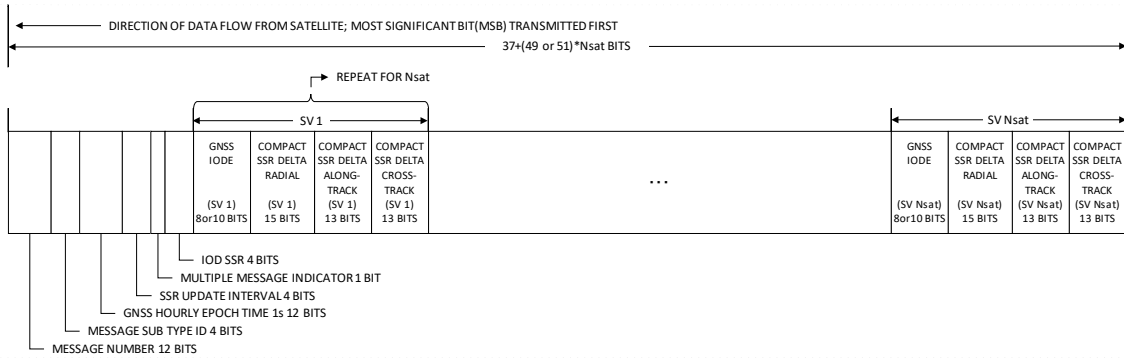

Figure 4.2.2-3 Compact SSR GNSS Orbit Correction Message structure

Table 4.2.2-10 Contents of message header, Compact SSR GNSS Orbit Correction Message

DF Name	DF Range	BIT	LSB	DF Unit	Note
Message Number	0-4095	12	-	-	4073
Message Sub Type ID	0-15	4	-	-	2
GNSS Hourly Epoch Time 1s	0-3599	12	1	s	3600-4095 indicates data not available
SSR Update Interval	0-15	4	1	-	
Multiple Message Indicator	0-1	1	-	-	
IOD SSR	0-15	4	1	-	

Table 4.2.2-11 Contents of satellite-specific part of Compact SSR GNSS Orbit Correction Message

DF Name	DF Range	BIT	LSB	DF Unit	Note
GNSS IODE (SV 1)	0-255 or 0-1023	8 or 10	1	-	
Compact SSR Delta Radial (SV 1)	±26.2128	15	0.0016	m	-26.2144 indicates data not available
Compact SSR Delta Along-Track (SV 1)	±26.208	13	0.0064	m	-26.2144 indicates data not available
Compact SSR Delta Cross-Track (SV 1)	±26.208	13	0.0064	m	-26.2144 indicates data not available
~					
GNSS IODE (SV N _{sat})	0-255 or 0-1023	8 or 10	1	-	
Compact SSR Delta Radial (SV N _{sat})	±26.2128	15	0.0016	m	-26.2144 indicates data not available
Compact SSR Delta Along-Track (SV N _{sat})	±26.208	13	0.0064	m	-26.2144 indicates data not available
Compact SSR Delta Cross-Track (SV N _{sat})	±26.208	13	0.0064	m	-26.2144 indicates data not available

(1) GNSS Hourly Epoch Time 1s

Hours, minutes, and seconds part of GPS epoch time.

(2) GNSS IODE

IODE value of broadcast ephemeris used for calculation of range correction. Here, 10-bit are assigned for Galileo, and 8-bit are assigned for other GNSS.

The definitions of GNSS IODE for each GNSS:

- GPS : Same as DF071 GPS IODE in applicable document (2) .
- GLONASS : Same as DF392 GLONASS IOD in applicable document (2) .
- Galileo : Same as DF290 Galileo IODnav in applicable document (2) .
- BDS : Ephemeris reference time toe modulo 2048.
- QZSS : Same as DF434 QZSS IODE in applicable document (2) .

(3) Compact SSR Delta Radial, Along-Track and Cross-Track

Radial, along-track and cross-track orbit correction for broadcast ephemeris. In the user algorithm, the appropriate broadcast ephemeris provided by the navigation message defined in Table 4.2.2-12 should be used.

Correction for LNAV and CNAV/CNAV-2 for GPS and QZSS are exclusively transmitted, The augmented navigation message is specified in by the L6 message type ID.

Table 4.2.2-12 Augmented Navigation Message

GNSS	Applicable navigation message extension in L6 message type ID	
	0	1
GPS	LNAV	CNAV/CNAV2
GLONASS (FDMA)	GLONASS-M	GLONASS-M
GLONASS (CDMA)	GLONASS-K	GLONASS-K
Galileo	I/NAV	I/NAV
QZSS	LNAV	CNAV/CNAV2
BeiDou	D1	D1

(4) IOD SSR

A change of issue of data SSR is used to indicate a change in the information included in the Compact SSR mask message.

4.2.2.4 Sub Type3 - Compact SSR GNSS Clock Correction Message

The sub type 3 message structure is shown in Figure 4.2.2-4. The message header and satellite-specific part are defined in Table 4.2.2-13 and Table 4.2.2-14, respectively.

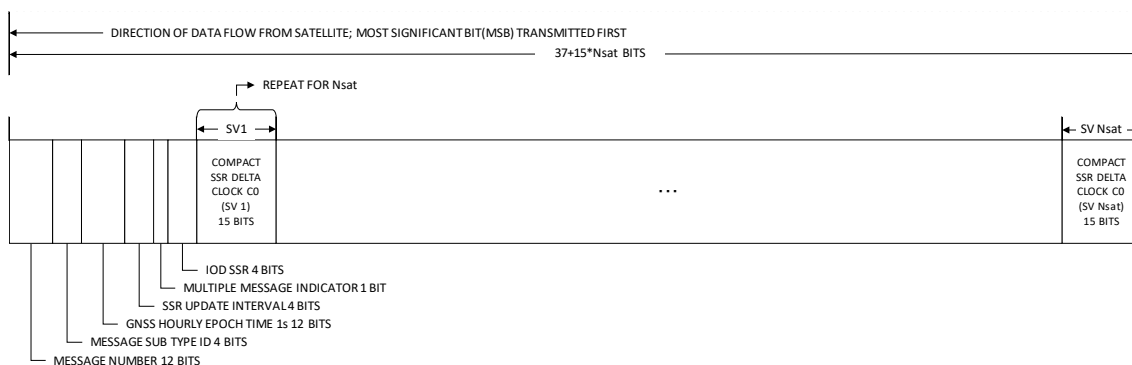

Figure 4.2.2-4 Compact SSR GNSS Clock Correction Message structure

Table 4.2.2-13 Contents of message header, Compact SSR GNSS Clock Correction Message

DF Name	DF Range	BIT	LSB	DF Unit	Note
Message Number	0-4095	12	-	-	4073
Message Sub Type ID	0-15	4	-	-	3
GNSS Hourly Epoch Time 1s	0-3599	12	1	s	3600-4095 indicates data not available
SSR Update Interval	0-15	4	1	-	
Multiple Message Indicator	0-1	1	-	-	
IOD SSR	0-15	4	1	-	

Table 4.2.2-14 Contents of satellite-specific part of Compact SSR GNSS Clock Correction Message

DF Name	DF Range	BIT	LSB	DF Unit	Note
Compact SSR Delta Clock C0 (SV1)	±26.2128	15	0.0016	m	-26.2144 indicates data not available
~					
Compact SSR Delta Clock C0 (SV N _{sat})	±26.2128	15	0.0016	m	-26.2144 indicates data not available

(1) Compact SSR Delta Clock

The bias term (C0) of clock correction for broadcast ephemeris. In the user algorithm, the appropriate broadcast ephemeris provided by the navigation message defined in Table 4.2.2-12 should be used.

4.2.2.5 Sub Type4 - Compact SSR GNSS Satellite Code Bias Message

The sub type 4 message structure is shown in Figure 4.2.2-5. The message header and satellite-specific part are defined in Table 4.2.2-15 and Table 4.2.2-16, respectively.

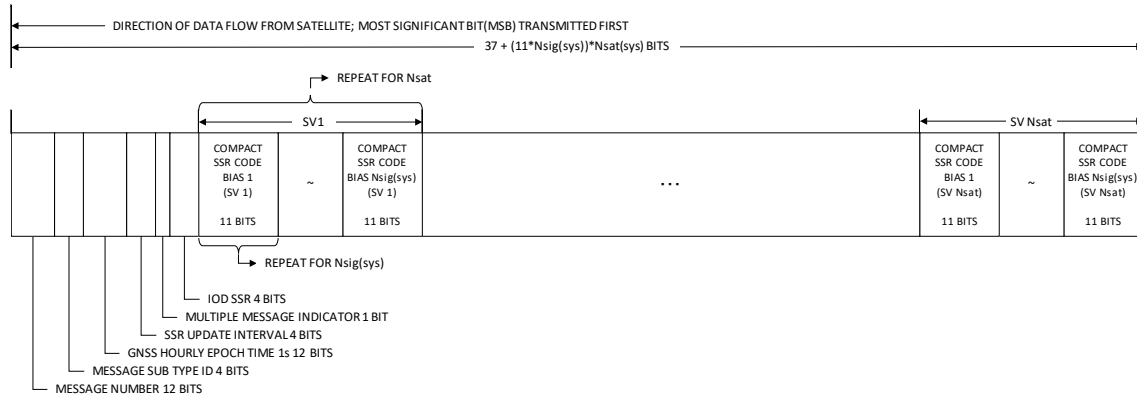

Figure 4.2.2-5 Compact SSR GNSS Satellite Code Bias Message structure

Table 4.2.2-15 Contents of message header, Compact SSR GNSS Satellite Code Bias Message

DF Name	DF Range	BIT	LSB	DF Unit	Note
Message Number	0-4095	12	-	-	4073
Message Sub Type ID	0-15	4	-	-	4
GNSS Hourly Epoch Time 1s	0-3599	12	1	s	3600-4095 indicates data not available
SSR Update Interval	0-15	4	1	-	
Multiple Message Indicator	0-1	1	-	-	
IOD SSR	0-15	4	1	-	

Table 4.2.2-16 Contents of satellite-specific part of Compact SSR GNSS Satellite Code Bias Message

DF Name	DF Range	BIT	LSB	DF Unit	Note
Compact SSR Code Bias 1 (SV 1)	± 20.46	11	0.02	m	-20.48 indicates data not available
~					
Compact SSR Code Bias $N_{\text{sig(sys)}}$ (SV 1)	± 20.46	11	0.02	m	-20.48 indicates data not available
~					
Compact SSR Code Bias 1 (SV N_{sat})	± 20.46	11	0.02	m	-20.48 indicates data not available
~					
Compact SSR Code Bias $N_{\text{sig(sys)}}$ (SV N_{sat})	± 20.46	11	0.02	m	-20.48 indicates data not available

(1) Compact SSR Code Bias

This code bias is an absolute value. The code biases should be added to the observed pseudorange of the corresponding code signal to get corrected pseudorange.

The Compact SSR code bias for the satellite of each GNSS is transmitted in the order indicated in sub type 1: Compact SSR Mask. Only the signal indicated by the Compact SSR cell mask is transmitted in this message.

4.2.2.6 Sub Type5 - Compact SSR GNSS Satellite Phase Bias Message

The sub type 5 message structure is shown in Figure 4.2.2-6. The message header and satellite-specific part are defined in Table 4.2.2-17 and Table 4.2.2-18, respectively.

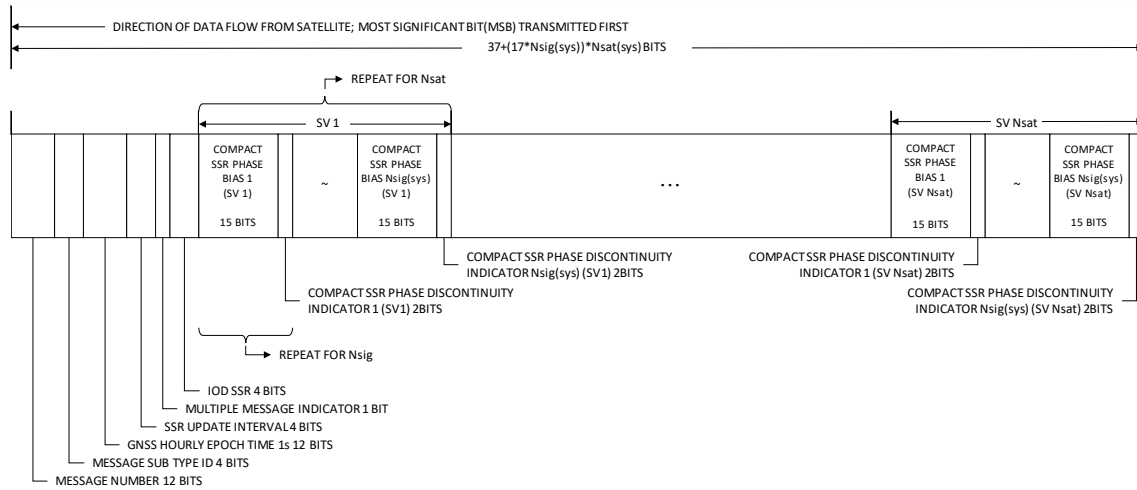

Figure 4.2.2-6 Compact SSR GNSS Satellite Phase Bias Message structure

Table 4.2.2-17 Contents of message header, Compact SSR GNSS Satellite Phase Bias Message

DF Name	DF Range	BIT	LSB	DF Unit	Note
Message Number	0-4095	12	-	-	4073
Message Sub Type ID	0-15	4	-	-	5
GNSS Hourly Epoch Time 1s	0-3599	12	1	s	3600-4095 indicates data not available
SSR Update Interval	0-15	4	1	-	
Multiple Message Indicator	0-1	1	-	-	
IOD SSR	0-15	4	1	-	

Table 4.2.2-18 Contents of satellite-specific part of Compact SSR GNSS Satellite Phase Bias Message

DF Name	DF Range	BIT	LSB	DF Unit	Note
Compact SSR Phase Bias 1 (SV 1)	± 16.383	15	0.001	m	-16.384 indicates data not available
Compact SSR Phase Discontinuity Indicator 1 (SV 1)	0-3	2	1	-	
~					
Compact SSR Phase Bias $N_{sig(sys)}$ (SV 1)	± 16.383	15	0.001	m	-16.384 indicates data not available
Compact SSR Phase Discontinuity Indicator $N_{sig(sys)}$ (SV 1)	0-3	2	1	-	
~					
Compact SSR Phase Bias 1 (SV N_{sat})	± 16.383	15	0.001	m	-16.384 indicates data not available
Compact SSR Phase Discontinuity Indicator 1 (SV N_{sat})	0-3	2	1	-	
~					
Compact SSR Phase Bias $N_{sig(sys)}$ (SV N_{sat})	± 16.383	15	0.001	m	-16.384 indicates data not available
Compact SSR Phase Discontinuity Indicator $N_{sig(sys)}$ (SV N_{sat})	0-3	2	1	-	

(1) Compact SSR Phase Bias

This phase bias is an absolute value. The phase biases should be added to the observed carrier-phase of the corresponding code signal to get corrected carrier-phase.

The Compact SSR phase bias for the satellite of each GNSS is transmitted in the order indicated by sub type 1: Compact SSR mask. Only the signal indicated by Compact SSR cell mask is transmitted in this message.

(2) Phase discontinuity indicator

The phase discontinuity indicator is counted up when the phase bias is discontinuous.

4.2.2.7 Sub Type7 - Compact SSR GNSS URA Message

The sub type 7 message structure is shown in Figure 4.2.2-7. The message header and satellite-specific part are defined in Table 4.2.2-19 and Table 4.2.2-20, respectively.

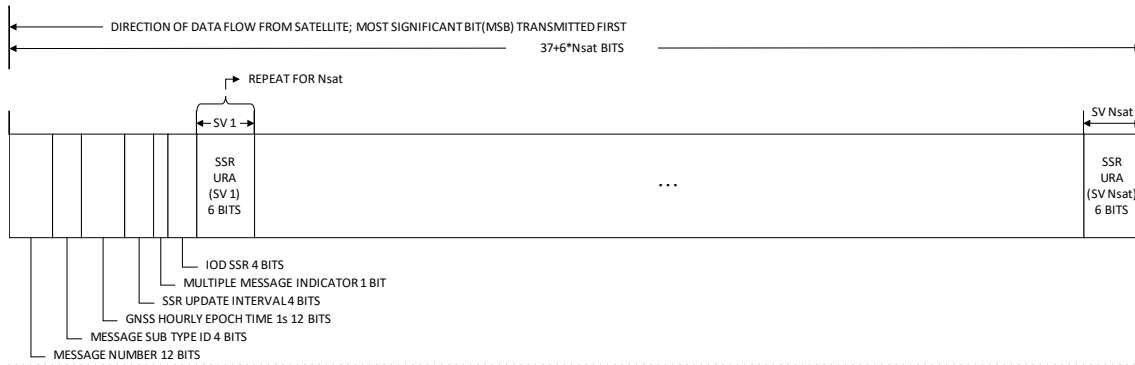

Figure 4.2.2-7 Compact SSR GNSS URA Message structure

Table 4.2.2-19 Contents of message header, Compact SSR GNSS URA Message

DF Name	DF Range	BIT	LSB	DF Unit	Note
Message Number	0-4095	12	-	-	4073
Message Sub Type ID	0-15	4	-	-	7
GNSS Hourly Epoch Time 1s	0-3599	12	1	s	3600-4095 indicates data not available
SSR Update Interval	0-15	4	1	-	
Multiple Message Indicator	0-1	1	-	-	
IOD SSR	0-15	4	1	-	

Table 4.2.2-20 Contents of satellite-specific part of Compact SSR GNSS URA Message

DF Name	DF Range	BIT	LSB	DF Unit	Note
SSR URA (SV 1)	bits5-3: 0-7 bits2-0: 0-7	6	-	-	
~					
SSR URA (SV N _{sat})	bits5-3: 0-7 bits2-0: 0-7	6	-	-	

(1) SSR URA

The SSR users range accuracy (URA) (1 sigma) for range correction computed from a complete signal in space specific SSR set as disseminated by the Compact SSR messages. The URA is represented by a combination of URA_CLASS and URA_VALUE. The 3 MSBs define the URA_CLASS within a range of 0-7 while the 3 LSBs define the URA_VALUE within a range of 0-7. The URA is computed by:

$$\text{SSR URA [mm]} \leq 3^{\text{URA_CLASS}} \left(1 + \frac{\text{URA_VALUE}}{4} \right) - 1 \text{ [mm]}$$

Special cases are:

000 000 : URA undefined/unknown

111 111 : URA > 5466.5 [mm]

If the SSR URA exceeds the user defined threshold for each application, user receivers can, for example, (a) discard the Compact SSR message, or (b) decrease the weight of the corresponding satellite observation in the positioning process.

4.2.2.8 Null Message

The preamble of the null message is a fixed value. PRN number is numbered (8-bit) with the PRN code to be used. Thus, the L6 message type ID is 0 and the Alert Flag is “1”_(B). The first 7-bit of the data part (1695-bit) are “0101010”_(B), and the other repeats the “10101010”_(B). User shall also refer to Section 5.4.2 for null message handling.

4.3 Transmission Pattern

Each sub type is transmitted at a rate of one cycle within 30 seconds, according to the transmission schedule. Table 4.2.2-1 and Figure 4.2.2-1 shows the nominal transmission pattern of the MADOCA-PPP sub type.

Note that the user algorithm should not assume any specific pattern.

Table 4.2.2-1 MADOCA-PPP Sub Type Transmission Pattern (Nominal)

Second	Subframe Number	Sub Type	Notes
0-4	1	1, 2, 3	-
5	2	-	QZNMA
6	3	-	QZNMA
7-9	4	3,7	-
10-14	5	3,4	-
15	6	-	QZNMA
16	7	-	QZNMA
17-19	8	3	-
20-24	9	3,5	-
25	10	-	QZNMA
26	11	-	QZNMA
27-29	12	3	-

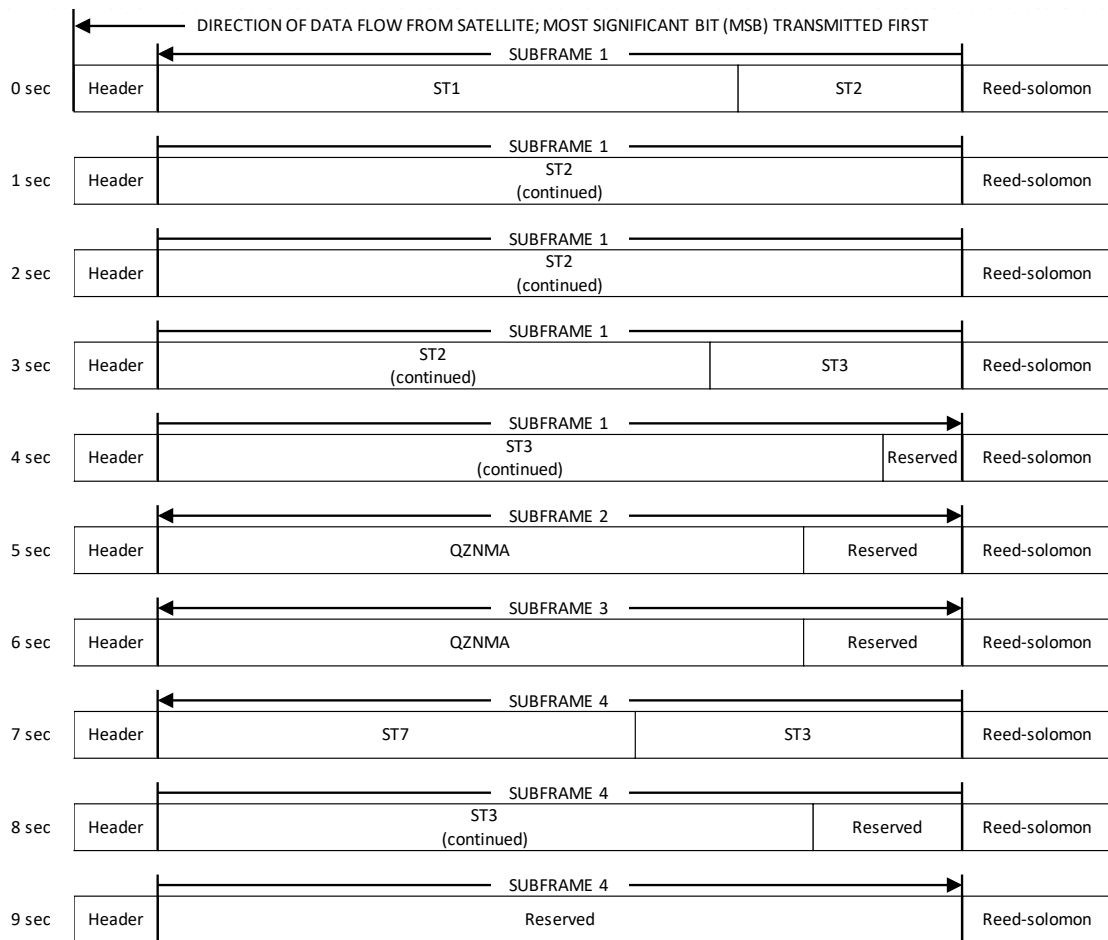

Figure 4.2.2-1 MADOCA-PPP Sub Type Transmission Pattern (Nominal)

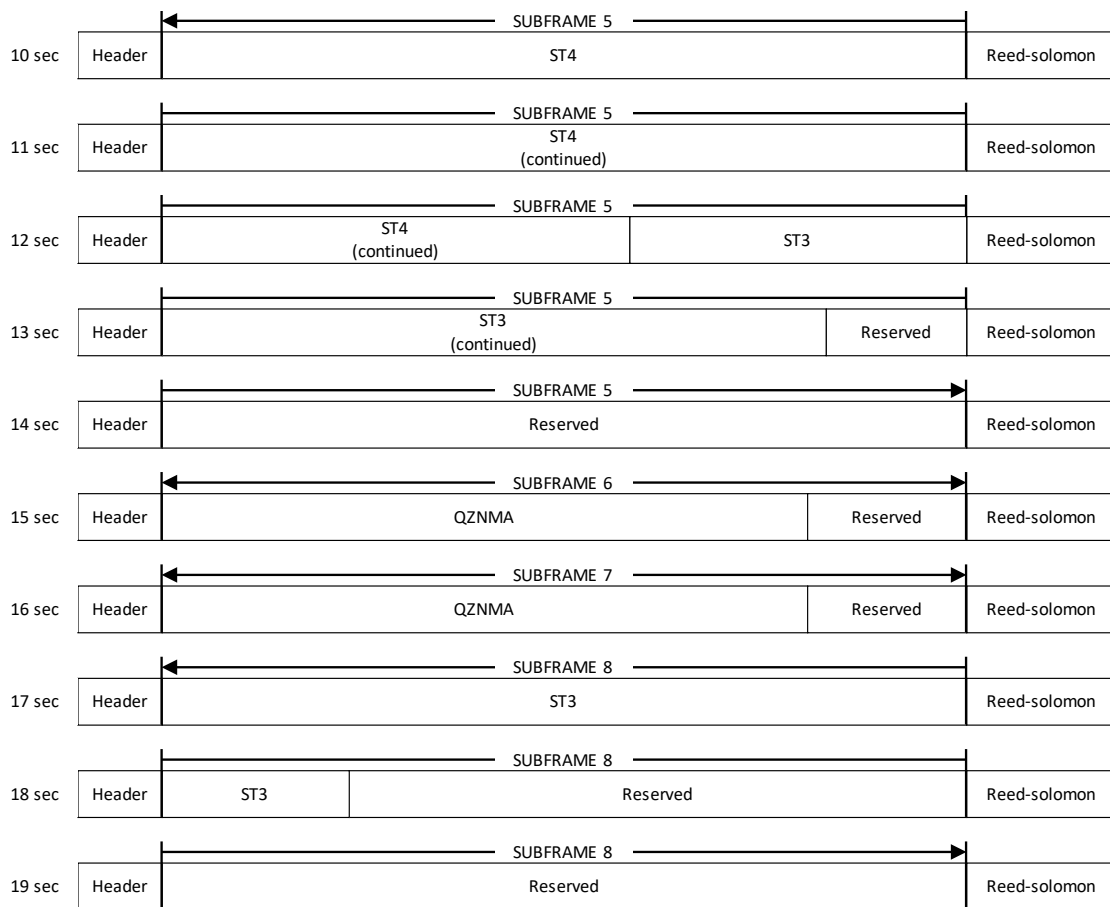

Figure 4.2.2-1 MADOCA-PPP Sub Type Transmission Pattern (Nominal) (continued)

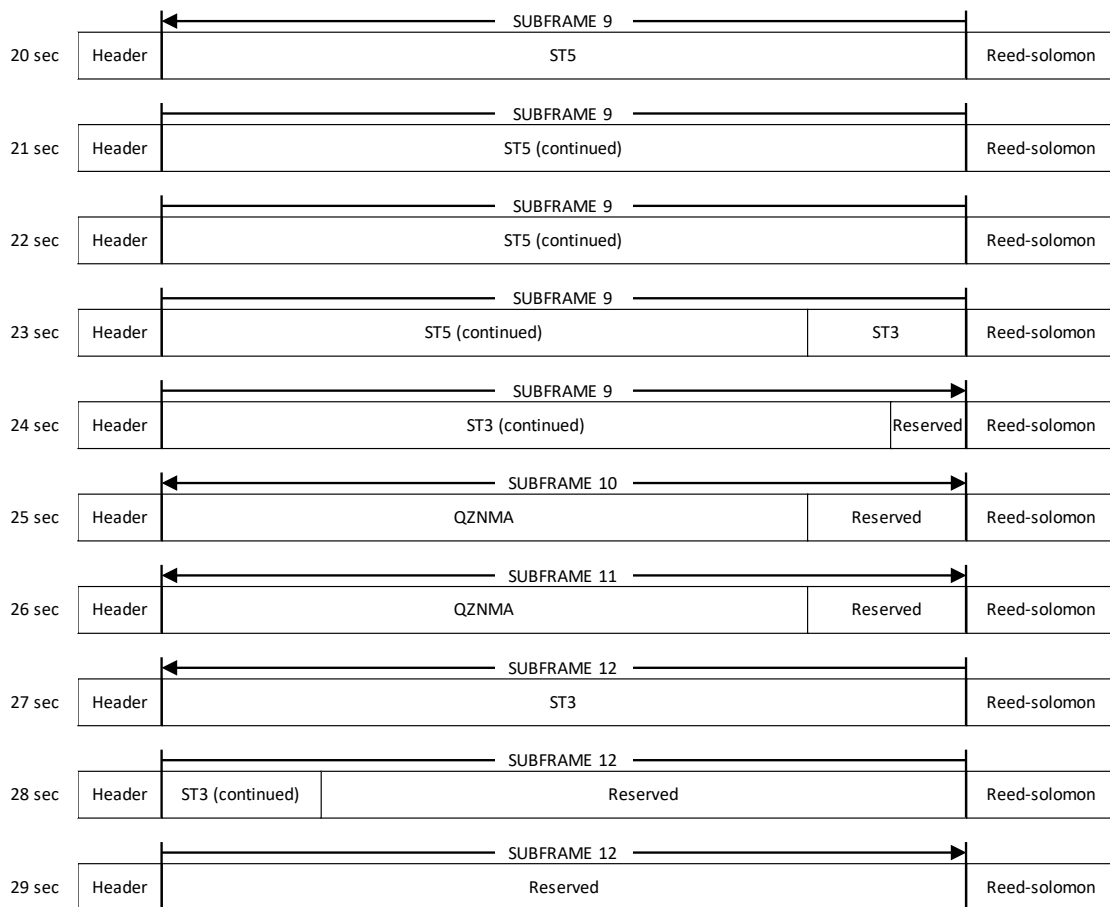

Figure 4.2.2-1 MADOCA-PPP Sub Type Transmission Pattern (Nominal) (continued)

4.4 FEC Encoded Algorithm

Reed-Solomon (255, 223) encoding is applied to the 1744-bit of the navigation message (preamble, PRN, message type ID, alert flag, and data section). Every 8-bit of the resulting bit-stream constitutes one symbol (See Section 4.4.1 for details.)

To add the 32-symbol (256-bit) Reed-Solomon code to the 218-symbol (1744-bit) navigation message, nine "0" symbols (72-bit) are inserted at the beginning of the 214-symbol (1712-bit) data bit string that does not include the 4-symbol (32-bit) preamble at the beginning of the header. The resulting 223-symbol (1784-bit) data bit string (with the 9 zero symbols inserted) is Reed-Solomon encoded (255,223) to generate a 32-symbol (256-bit) parity word. The 250 symbols (2000-bit) that comprise the 32-symbol parity words added to the original 218-symbol (1744-bit) data bit string (including the preamble) are then input to the CSK modulator (see Figure 4.4-1).

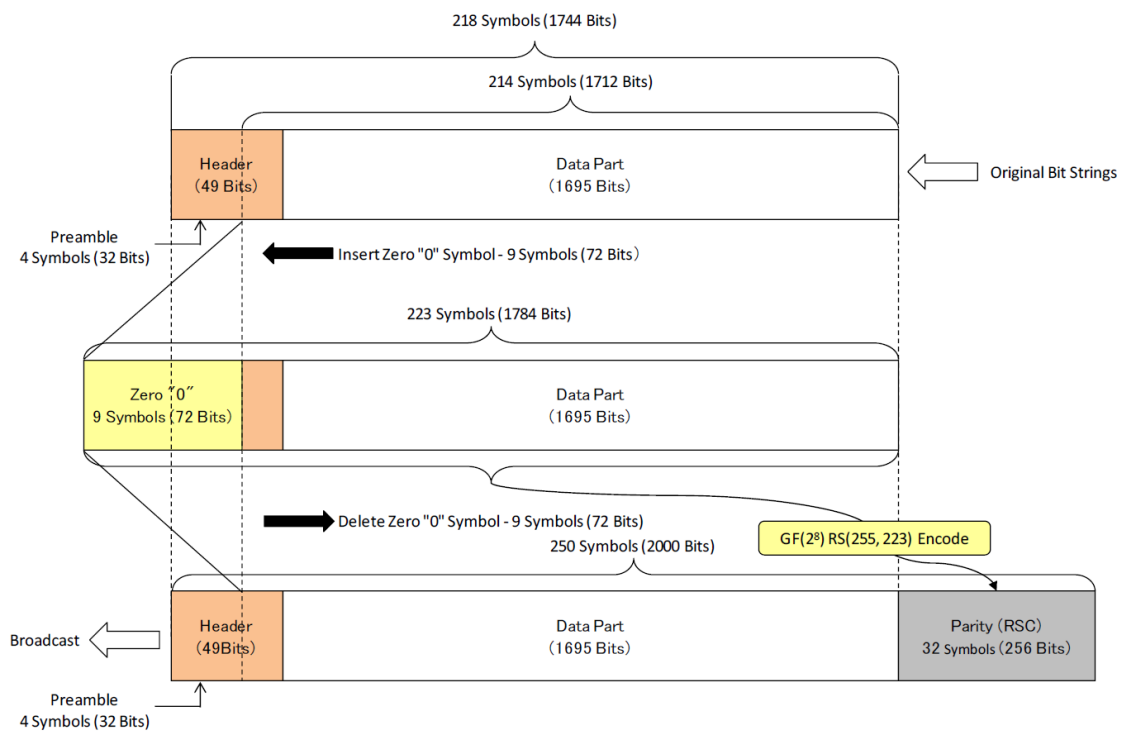

Figure 4.4-1 Encoding of Reed-Solomon code

4.4.1 Reed-Solomon Coding/Decoding Algorithm for L6 Navigation Message

(1) Construct Galois Field $GF(2^8)$

We choose $F(x) = x^8 + x^7 + x^2 + x + 1$ as a primitive polynomial of degree 8 over \mathbf{Z}_2 . (Note that, because this is the binary case, addition(+) is equivalent to exclusive-OR (XOR) and multiplication(\times) is equivalent to the logical AND operation.) When α is a root of $F(x) = 0$, we have the following (note that $\alpha^8 = -\alpha^8$ over \mathbf{Z}_2):

$$\alpha^8 = -\alpha^8 = \alpha^7 + \alpha^2 + \alpha + 1 \quad 4.4.1-1$$

From equation 4.4.1-1 any power of α can be represented by a linear combination of $\alpha^7, \alpha^6, \alpha^5, \alpha^4, \alpha^3, \alpha^2, \alpha^1, \alpha^0 (= 1)$ over \mathbf{Z}_2 (note that $\alpha^i + \alpha^i = 0$) as follows:

$$\begin{aligned} \alpha^8 &= \alpha^7 + \alpha^2 + \alpha + 1 \\ \alpha^9 &= \alpha^8 \times \alpha = \alpha^8 + \alpha^3 + \alpha^2 + \alpha \\ &= (\alpha^7 + \alpha^2 + \alpha + 1) + \alpha^3 + \alpha^2 + \alpha \\ &= \alpha^7 + \alpha^3 + 1 \\ \alpha^{10} &= \alpha^9 \times \alpha = \alpha^8 + \alpha^4 + \alpha \\ &= (\alpha^7 + \alpha^2 + \alpha + 1) + \alpha^4 + \alpha \\ &= \alpha^7 + \alpha^4 + \alpha^2 + 1 \\ &\vdots \\ \alpha^{254} &= \alpha^7 + \alpha^6 + \alpha + 1 \end{aligned} \quad 4.4.1-2$$

Then, the order of α is 255, since:

$$\begin{aligned} \alpha^{255} &= \alpha^{254} \times \alpha = \alpha^8 + \alpha^7 + \alpha^2 + \alpha \\ &= (\alpha^7 + \alpha^2 + \alpha + 1) + \alpha^7 + \alpha^2 + \alpha \\ &= 1 + \alpha^0 \end{aligned} \quad 4.4.1-3$$

From equations 4.4.1-3, the addition of two powers of α is as follows: When

$$\alpha^m = \mu_{m7}\alpha^7 + \mu_{m6}\alpha^6 + \dots + \mu_{m1}\alpha^1 + \mu_{m0} \quad 4.4.1-4$$

$$\alpha^n = \mu_{n7}\alpha^7 + \mu_{n6}\alpha^6 + \dots + \mu_{n1}\alpha^1 + \mu_{n0} \quad 4.4.1-5$$

the addition is given by:

$$\begin{aligned} \alpha^m + \alpha^n &= (\mu_{m7} + \mu_{n7})\alpha^7 + (\mu_{m6} + \mu_{n6})\alpha^6 + \\ &\quad \dots (\mu_{m1} + \mu_{n1})\alpha^1 + (\mu_{m0} + \mu_{n0})\alpha^0 \\ &= \alpha^1 \end{aligned} \quad 4.4.1-6$$

Each μ_{mj}, μ_{nj} coefficient is either a zero or a one, and $\mu_{mj} + \mu_{nj}$ is the logical "exclusive OR" of the two coefficients. As a result of the above operations, $\{0, 1 (= \alpha^0), \alpha^1, \alpha^2, \dots, \alpha^{254}\}$ makes a Galois Field $GF(2^8)$.

(2) Change of Basis

From equations 4.4.1-2, one basis for $\{0,1(=\alpha^0),\alpha^1,\alpha^2,\dots,\alpha^{254}\}$ over \mathbf{Z}_2 is the set $\{\alpha^7,\alpha^6,\alpha^5,\alpha^4,\alpha^3,\alpha^2,\alpha^1,\alpha^0\}$.

When $l_0 = \alpha^{125}, l_1 = \alpha^{88}, l_2 = \alpha^{226}, l_3 = \alpha^{163}, l_4 = \alpha^{46}, l_5 = \alpha^{184}, l_6 = \alpha^{67}, l_7 = \alpha^{242}$, the set $\{l_0, l_1, l_2, l_3, l_4, l_5, l_6, l_7\}$ is another basis for $\{0,1(=\alpha^0),\alpha^1,\alpha^2,\dots,\alpha^{254}\}$ over \mathbf{Z}_2 . When the n th power of α is represented by two linear combinations:

$$\begin{aligned} \alpha^n &= u_7\alpha^7 + u_6\alpha^6 + u_5\alpha^5 + u_4\alpha^4 + u_3\alpha^3 \\ &\quad + u_2\alpha^2 + u_1\alpha^1 + u_0\alpha^0 \\ &= z_0l_0 + z_1l_1 + z_2l_2 + z_3l_3 + z_4l_4 + z_5l_5 + z_6l_6 + z_7l_7 \end{aligned} \quad 4.4.1-7$$

The relationship between $u_7, u_6, u_5, u_4, u_3, u_2, u_1, u_0$ and $z_0, z_1, z_2, z_3, z_4, z_5, z_6, z_7$ is given by the following two equations:

$$(z_0, z_1, z_2, z_3, z_4, z_5, z_6, z_7) = \begin{pmatrix} u_7 \\ u_6 \\ u_5 \\ u_4 \\ u_3 \\ u_2 \\ u_1 \\ u_0 \end{pmatrix}^t \begin{pmatrix} 1 & 0 & 0 & 0 & 1 & 1 & 0 & 1 \\ 1 & 1 & 1 & 0 & 1 & 1 & 1 & 1 \\ 1 & 1 & 1 & 0 & 1 & 1 & 0 & 0 \\ 1 & 0 & 0 & 0 & 0 & 1 & 1 & 0 \\ 1 & 1 & 1 & 1 & 1 & 0 & 1 & 0 \\ 1 & 0 & 0 & 1 & 1 & 0 & 0 & 1 \\ 1 & 0 & 1 & 0 & 1 & 1 & 1 & 1 \\ 0 & 1 & 1 & 1 & 1 & 0 & 1 & 1 \end{pmatrix} \quad 4.4.1-8$$

$$(u_7, u_6, u_5, u_4, u_3, u_2, u_1, u_0) = \begin{pmatrix} z_0 \\ z_1 \\ z_2 \\ z_3 \\ z_4 \\ z_5 \\ z_6 \\ z_7 \end{pmatrix}^t \begin{pmatrix} 1 & 1 & 0 & 0 & 0 & 1 & 0 & 1 \\ 0 & 1 & 0 & 0 & 0 & 0 & 1 & 0 \\ 0 & 0 & 1 & 0 & 1 & 1 & 1 & 0 \\ 1 & 1 & 1 & 1 & 1 & 1 & 0 & 1 \\ 1 & 1 & 1 & 1 & 0 & 0 & 0 & 0 \\ 0 & 1 & 1 & 1 & 1 & 0 & 0 & 1 \\ 1 & 0 & 1 & 0 & 1 & 1 & 0 & 0 \\ 1 & 1 & 0 & 0 & 1 & 1 & 0 & 0 \end{pmatrix} \quad 4.4.1-9$$

Each u_i, z_j coefficient is either a zero or a one, and the addition of these matrix operations is simply "exclusive OR".

(3) Encoding

When the header and data parts of the L6 message are given, the Reed-Solomon encoding is performed as follows:

The target encoded length is 214 symbols (5 to 218) followed by the Preamble. Consider the bits in each symbol to be $z_0, z_1, z_2, z_3, z_4, z_5, z_6, z_7$ corresponding to the elements of $\{0, 1 (= \alpha^0), \alpha^1, \alpha^2, \dots, \alpha^{254}\}$ (see Section (2)). When the binary string 5th, 6th, \dots , 218th symbol is represented by A_5, A_6, \dots, A_{218} ($A_i \in \{0, 1 (= \alpha^0), \alpha^1, \alpha^2, \dots, \alpha^{254}\}$) polynomial $I(x)$ over $\{0, 1 (= \alpha^0), \alpha^1, \alpha^2, \dots, \alpha^{254}\}$ defined as follows:

$$I(x) = A_5 x^{213} + A_6 x^{212} + \dots + A_{217} x + A_{218} \quad 4.4.1-10$$

If the code generator polynomial over $\{0, 1 (= \alpha^0), \alpha^1, \alpha^2, \dots, \alpha^{254}\}$ is defined as follows:

$$g(x) = \prod_{j=112}^{143} (x - \alpha^{11j}) \quad 4.4.1-11$$

Then, $P(x)$ is the remainder after dividing $x^{32}I(x)$ by $g(x)$. Division is used for the operation of the Galois Field $\{0, 1 (= \alpha^0), \alpha^1, \alpha^2, \dots, \alpha^{254}\}$ (see Section (1)).

$P(x)$ is written as follows:

$$P(x) = B_1 x^{31} + B_2 x^{30} + \dots + B_{31} x + B_{32} \quad 4.4.1-12$$

$B_i \in \{0, 1 (= \alpha^0), \alpha^1, \alpha^2, \dots, \alpha^{254}\}$

When each B_i is represented by a linear combination of set $\{l_0, l_1, l_2, l_3, l_4, l_5, l_6, l_7\}$:

$$B_i = z_0 l_0 + z_1 l_1 + z_2 l_2 + z_3 l_3 + z_4 l_4 + z_5 l_5 + z_6 l_6 + z_7 l_7 \quad 4.4.1-13$$

The 32-symbol Reed-Solomon Code is generated by thinking of $z_0, z_1, z_2, z_3, z_4, z_5, z_6, z_7$ as the bits of the symbol.

(4) Decoding

Similarly, in Section (3), the polynomial $S(x)$ is generated as follows from the 5th to 250th symbols of the received message.

$$S(x) = A'_5 x^{245} + A'_6 x^{244} + \dots + A'_{249} x + A'_{250} \quad 4.4.1-14$$

Thus, by employing this R-S encoding/decoding, we can detect errors and correct those up until 16 symbol errors occur, by computing 32 polynomials $S(\alpha^{11j}), j = 112 \sim 143$. Provided there are no errors, $S(\alpha^{11j})$ is all zeroes.

5. User Algorithms

5.1 Time System

The time system of QZSS is called QZSST and has the following characteristics.

(1) Definition

(a) One-second length

The length of one second is identical to International Atomic Time (TAI).

(b) Integer second offset for TAI

The integer second offset for TAI is the same as that for GPS and TAI is always 19 seconds ahead of QZSST.

(c) Starting point of week number for QZSST

The starting point of the week number for QZSST is identical to that for GPST (January 6, 1980).

(2) Time system of "Epoch Time" in Compact SSR messages

Data field "GNSS Epoch Time 1s" or "GNSS Hourly Epoch Time 1s" in each Compact SSR message, transmitted from QZS, are represented in QZSST.

5.2 Coordinate System

The reference frame of the MADOCA-PPP corrections is aligned to ITRF. The applied version of ITRF is published at the Service Support Information page (<https://qzss.go.jp/en/technical/dod/madoca/coordinate-system.html>) on the QZSS website.

5.3 Constants

5.3.1 Speed of Light

Expressed using a small letter "c".

The value is $c = 299792458$ m/s.

5.3.2 Circular Constant

Expressed using the Greek symbol " π ".

The value is $\pi = 3.1415926535898$.

5.4 Integrity

Integrity for MADOCA-PPP is implemented. Integrity information in MADOCA-PPP consists of the Alert flag and the null message.

5.4.1 Alert Flag

The 1-bit Alert flag that follows the message type ID in each message indicates the comprehensive health status for the satellite system, ground system, and external systems configured in MADOCA-PPP.

When the Alert flag is "1"_(B) and Vendor ID in the L6 message type ID is "010"_(B)(MADOCA-PPP), this indicates a situation in which MADOCA-PPP should not be used. In this case, the L6 signal should be used at the user's own risk.

5.4.2 Null Message

The null message indicates message missing due to communications link problem or system interruption. Even if a null message transmitted by the satellite, user can use the previous MADOCA-PPP correction data within the validity interval.

5.5 Calculation Algorithms for Compact SSR

This section shows the Compact SSR calculation algorithms for MADOCA-PPP, which are also defined in the applicable document (3). Observation equations using the Compact SSR are shown in the section 5.5.5.

(1) Reference point by the MADOCA-PPP correction data

The reference point by the MADOCA-PPP correction data is the antenna phase center of the ionosphere-free combination signal indicated Table 5.5-1. The antenna phase center is calculated by applying the phase center offsets (PCOs) and variations (PCVs) correction from the IGS ANTEX files to the satellite center of mass. Therefore, when using signals other than shown in Table 5.5-1, a more accurate corrections can be made by converting to the antenna phase center at the desired frequency from the satellite center of mass using the ANTEX files and IGS conventional satellite attitude low models described in the reference document (10) and (11).

The applied version of ANTEX file is published at the Service Support Information page (<https://qzss.go.jp/en/technical/dod/madoca/coordinate-system.html>) on the QZSS website.

Table 5.5-1 GNSS reference point

GNSS	Signal
GPS	L1C/A and L2P
GLONASS	G1 C/A and G2 P
Galileo	E1 OS and E5a
QZSS	L1C and L5

5.5.1 Calculation of GNSS Clock Correction

5.5.1.1 Parameter

Table 5.5.1-1 lists the parameters defined in the Compact SSR GNSS Clock Correction message.

Table 5.5.1-2 lists the parameter required for the calculations.

Table 5.5.1-1 Compact SSR GNSS Clock Correction message parameters

Parameter	Definition	Unit
C_0	Compact SSR Delta Clock (sub type3)	m

Table 5.5.1-2 Other parameters

Parameter	Definition	Unit
c	Speed of Light (Section 5.3.1.)	m/s

5.5.1.2 Algorithm

Satellite clock correction δC establishes the following relationship between the parameters of the Compact SSR GNSS clock correction.

$$\delta C = C_0$$

The relationship among the SV clock $t_{broadcast}$ derived from the broadcast SV clock parameter, the Satellite clock correction δC derived from the Compact SSR GNSS clock correction message, and the corrected SV clock $t_{satellite}$ are as follows:

$$t_{satellite} = t_{broadcast} - \frac{\delta C}{c}$$

The algorithms are same for GPS, QZSS, Galileo, GLONASS, and BeiDou.

Note that users should compute the satellite time $t_{broadcast}$ according to corresponding each GNSS ICD (see reference document (1) (6) (7) (8) (9)) from broadcast parameters, identified by IODE in latest Compact SSR GNSS Orbit Correction message. Additionally the relativity correction should be applied to compute $t_{broadcast}$ for GPS, QZSS, Galileo and BeiDou. The relativistic effects are already taken into account in the broadcast clock parameters for GLONASS.

5.5.2 Calculation of GNSS Orbit Correction

5.5.2.1 Parameters

Table 5.5.2-1 lists the parameters defined in the Compact SSR GNSS Orbit Correction message.

Table 5.5.2-2 lists the other parameters required for the calculations.

Table 5.5.2-1 Compact SSR GNSS Orbit Correction message parameters

Parameter	Definition	Unit
δO_{radial}	Compact SSR Delta Radial (sub type2)	m
δO_{along}	Compact SSR Delta Along Track (sub type2)	m
δO_{cross}	Compact SSR Delta Cross Track (sub type2)	m

Table 5.5.2-2 Other parameters

Parameter	Definition	Unit
δX	Satellite Orbit Correction	m
e_{radial}	Delta Radial Unit Vector	-
e_{along}	Delta Along Track Unit Vector	-
e_{cross}	Delta Cross Track Unit Vector	-
r	Satellite Position calculated from broadcast ephemeris	m
\dot{r}	Satellite Speed calculated from broadcast ephemeris	m/s

5.5.2.2 Algorithm

Satellite orbit correction $\delta\mathbf{X}$ at time t is calculated as follows:

$$\delta\mathbf{X} = [\mathbf{e}_{radial} \quad \mathbf{e}_{along} \quad \mathbf{e}_{cross}] \begin{bmatrix} \delta O_{radial} \\ \delta O_{along} \\ \delta O_{cross} \end{bmatrix}$$

where

$$\mathbf{e}_{along} = \frac{\dot{\mathbf{r}}(t)}{|\dot{\mathbf{r}}(t)|}$$

$$\mathbf{e}_{cross} = \frac{\mathbf{r}(t) \times \dot{\mathbf{r}}(t)}{|\mathbf{r}(t) \times \dot{\mathbf{r}}(t)|}$$

$$\mathbf{e}_{radial} = \mathbf{e}_{along}(t) \times \mathbf{e}_{cross}(t)$$

The relationship among the satellite position \mathbf{r} derived from the broadcast ephemeris, the satellite orbit correction $\delta\mathbf{X}$ derived from the Compact SSR GNSS orbit correction message, and the corrected satellite ECEF position $\mathbf{X}_{orbit(ECEF)}$ are as follows:

$$\mathbf{X}_{orbit(ECEF)} = \mathbf{r} - \delta\mathbf{X}$$

The algorithms are same for GPS, QZSS, Galileo, GLONASS and BeiDou.

Note that users should compute the satellite position \mathbf{r} according to corresponding each GNSS ICD (see reference document (1) (6) (7) (8) (9)) from broadcast parameters, identified by IODE in Compact SSR GNSS Orbit Correction message.

5.5.3 Calculation of GNSS Code/Phase Bias

5.5.3.1 Applicable Signals of Code/Phase Bias

The Code/Phase Bias which are provided by MADOCA-PPP shall be applied to the pseudo range/carrier phase range based on the lists as shown in Table 5.5.3-1 - Table 5.5.3-5.

Table 5.5.3-1 Applicable Signals of Code/Phase Bias (GPS)

MADOCA-PPP Code/Phase Bias (GPS)		User Applicable Signals
Signal mask bit	Signal name	
0	L1 C/A	L1 C/A
2	L1 Z-tracking	L1 P L1 Z-tracking
5	L1 L1C(D+P)	L1 L1C(D) L1 L1C(P) L1C(D+P)
8	L2 L2C(M+L)	L2 L2C(M) L2 L2C(L) L2 L2C(M+L)
10	L2 Z-tracking	L2 P L2 Z-tracking
13	L5 I+Q	L5 I L5 Q L5 I+Q

Table 5.5.3-2 Applicable Signals of Code/Phase Bias (GLONASS)

MADOCA-PPP Code/Phase Bias (GLONASS)		User Applicable Signals
Signal mask bit	Signal name	
0	G1 C/A	G1 C/A
1	G1 P	G1 P
2	G2 C/A	G2 C/A
3	G2 P	G2 P
6	G1a(D+P)	G1a(D) G1a(P) G1a(D+P)
9	G2a(D+P)	G2a(D) G2a(P) G2a(D+P)
12	G3 I+Q	G3 I G3 Q G3 I+Q

Table 5.5.3-3 Applicable Signals of Code/Phase Bias (Galileo)

MADDOCA-PPP Code/Phase Bias (Galileo)		User Applicable Signals
Signal mask bit	Signal name	
2	E1 B+C	E1 B I/NAV OS/CS/SoL E1 C no data E1 B+C
5	E5a I+Q	E5a I F/NAV OS E5a Q no data E5a I+Q
8	E5b I+Q	E5b I I/NAV OS/CS/SoL E5b Q no data E5b I+Q
11	E5 I+Q	E5 I E5 Q E5 I+Q
12	E6 B	E6 B E6 C

Table 5.5.3-4 Applicable Signals of Code/Phase Bias (QZSS)

MADDOCA-PPP Code/Phase Bias (QZSS)		User Applicable Signals
Signal mask bit	Signal name	
0	L1 C/A	L1 C/A
3	L1 L1C(D+P)	L1 L1C(D) L1 L1C(P) L1 L1C(D+P)
6	L2 L2C(M+L)	L2 L2C(M) L2 L2C(L) L2 L2C(M+L)
9	L5 I+Q	L5 I L5 Q L5 I+Q
10	L6D	L6D L6P
12	L6E	L6E
13	L1C/B	L1C/B

Table 5.5.3-5 Applicable Signals of Code/Phase Bias (BeiDou)

MADOCA-PPP Code/Phase Bias (BeiDou)		User Applicable Signals
Signal mask bit	Signal name	
2	B1 I+Q	B1 I B1 Q B1 I+Q
5	B3 I+Q	B3 I B3 Q B3 I+Q
8	B2 I+Q	B2b I B2b Q B2b I+Q

5.5.3.2 Parameters

Table 5.5.3-6 lists the parameters defined in the Compact SSR Satellite Code Bias message and Compact SSR Satellite Phase Bias message. Table 5.5.3-7 lists the other parameters required for the calculations.

Table 5.5.3-6 Compact SSR GNSS Code/Phase Bias Correction message parameters

Parameter	Definition	Unit
$BIAS_{code}^{PRN}$	Compact SSR Code Bias (sub type4)	m
$BIAS_{phase}^{PRN}$	Compact SSR Phase Bias (sub type5)	m
PDI_{phase}^{PRN}	Phase Discontinuity Indicator (sub type5)	-

Table 5.5.3-7 Other parameters

Parameter	Definition	Unit
$P_{observed}^{PRN}$	Observed pseudorange	m
$\phi_{observed}^{PRN}$	Observed carrier-phase	cycle
λ^{PRN}	Wavelength of the carrier frequency	m

5.5.3.3 Algorithm

The Compact SSR Code/Phase Bias should be added to the observed pseudorange/carrier-phase of the corresponding code signal to get the corrected pseudorange/carrier-phase.

Corrected pseudorange P^{PRN} and corrected carrier-phase ϕ^{PRN} are calculated by

$$P^{PRN} = P_{observed}^{PRN} + BIAS_{code}^{PRN}$$

$$\phi^{PRN} = \phi_{observed}^{PRN} + \frac{BIAS_{phase}^{PRN}}{\lambda^{PRN}}$$

The algorithms are same for GPS, QZSS, Galileo, GLONASS and BeiDou. The all phase biases for GLONASS(FDMA) are set to zero due to the receiver dependent biases for FDMA signals.

Note that the sign definitions of the Code/Phase biases in MADOC-PPP are opposite to those in CLAS defined in the applicable document (4) Section 5.5.7.

The ambiguity estimation shall be re-initialized for the corresponding satellite and signal when the Phase Discontinuity Indicator PDI_{phase}^{PRN} for the satellite (PRN) and signal ($phase$) is incremented. For thus, it is recommended that the phase bias correction be applied only when performing integer ambiguity resolution.

5.5.4 (Reference) User dependent errors

The estimated Compact SSR parameters of MADOCA-PPP are free of reference station site displacements, phase wind-up effect, receiver antenna PCV, inter system bias, quarter cycle shifts and other errors. Users should apply corresponding user dependent corrections when using Compact SSR parameters in the positioning calculation process.

The MADOCA-PPP observation model is the ionosphere-free combination of the dual-frequency carrier phase and pseudorange observations. The following correction models should be considered to meet the MADOCA-PPP convergence time described in the applicable document (1) .

- solid earth tides
- ocean loading
- pole tide
- phase wind-up
- receiver antenna phase center offset and variation (PCO, PCV)
- receiver inter system bias (ISB)
- receiver quarter cycle carrier phase shifts
(if provided carrier phase bias for different signals on the same frequency)
- tropospheric delay

References for user site displacements such as solid earth tide, ocean loading and pole tide are the IERS Conventions (3) Section 7. Reference for phase wind-up correction is the reference document (2) . Reference for the estimation of tropospheric delay is the reference document (4) Section 3.

5.5.5 (Reference) Observation Equations

5.5.5.1 Parameter

Table 5.5.5-1 lists the parameters defined in Section 5.5.1 , 5.5.2 and 5.5.3 . These parameters are used for calculations of the pseudorange correction and the carrier-phase correction for the satellite PRN.

Table 5.5.5-1 Parameters

Parameter	Definition	Unit
$t_{satellite}^{PRN}$	Satellite clock corrected by Compact SSR GNSS Clock Correction message (see Section 5.5.1)	s
$\mathbf{x}_{orbit(ECEF)}^{PRN}$	Satellite ECEF position corrected by Compact SSR GNSS Orbit Correction message (see Section 5.5.2)	m
p^{PRN}	Pseudorange observation corrected by Compact SSR Code Bias message (see Section 5.5.3)	m
ϕ^{PRN}	Carrier-phase observation corrected by Compact SSR Phase Bias message (see Section 5.5.3)	cycle

5.5.5.2 Algorithm

The ionosphere-free combinations of dual-frequency pseudorange and carrier-phase observations for the satellite PRN are related to the user position, clock, troposphere and ambiguity parameter according to the following simplified observation equations:

$$P_{IF}^{PRN} = \rho^{PRN} + c(dT_{GNSS} - t_{satellite}^{PRN}) + T_r^{PRN} + \varepsilon_p^{PRN}$$

$$\phi_{IF}^{PRN} = \rho^{PRN} + c(dT_{GNSS} - t_{satellite}^{PRN}) + T_r^{PRN} + N_{IF}\lambda_{IF} + \varepsilon_\phi^{PRN}$$

where

P_{IF}	: ionosphere-free combination of $F1$ pseudorange and $F2$ pseudorange $(f_1^2 P_1^{PRN} - f_2^2 P_2^{PRN}) / (f_1^2 - f_2^2)$
ϕ_{IF}	: ionosphere-free combination of $F1$ carrier-phase and $F2$ carrier-phase $(f_1^2 \lambda_1 \phi_1^{PRN} - f_2^2 \lambda_2 \phi_2^{PRN}) / (f_1^2 - f_2^2)$
$F1, F2$: two signals used for ionosphere-free combination (these signals must be different frequencies)
P_1^{PRN}, P_2^{PRN}	: $F1, F2$ pseudorange observation corrected by Compact SSR Code Bias message
$\phi_1^{PRN}, \phi_2^{PRN}$: $F1, F2$ carrier-phase observation corrected by Compact SSR Phase Bias message
f_1, f_2	: $F1, F2$ frequencies
λ_1, λ_2	: $F1, F2$ wavelength
λ_{IF}	: combined wavelength corresponding to the frequency f_1 and f_2 $(f_1^2 \lambda_1 - f_2^2 \lambda_2) / (f_1^2 - f_2^2)$
dT_{GNSS}	: receiver clock offset of each GNSS from the QZSST
T_r^{PRN}	: tropospheric delay
N_{IF}	: non-integer ambiguity of the carrier-phase ionosphere-free combination
$\varepsilon_p^{PRN}, \varepsilon_\phi^{PRN}$: relevant measurement noise components including multipath

ρ^{PRN} is the geometrical range computed by satellite position corrected by orbit correction $\mathbf{X}_{orbit(ECEF)}^{PRN} = (x_{orbit}^{PRN}, y_{orbit}^{PRN}, z_{orbit}^{PRN})$ and user position $(x_{user}, y_{user}, z_{user})$ as follow:

$$\rho^{PRN} = \sqrt{(x_{orbit}^{PRN} - x_{user})^2 + (y_{orbit}^{PRN} - y_{user})^2 + (z_{orbit}^{PRN} - z_{user})^2}$$

Note that the user receiver side specific compensations such as user site displacements, phase wind-up, user receiver antenna phase center offset (PCO), user receiver phase center variation (PCV), and quarter cycle carrier phase shifts which are described in 5.5.4 are not included in these observation equations. Users should apply the compensations to the GNSS observation data (both carrier phase and pseudo range) in the positioning calculation process.

6. Correction Information for the Technology Demonstration

6.1 General

Wide-range ionospheric correction for the Asia and Oceania regions is transmitted by the L6D messages to shorten the convergence time of MADOCA-PPP.

The service area of the ionospheric correction within the Asia and Oceania regions provided using the L6D message is identified by RegionID from 0 to 255. One Region consists of multiple Areas and is assigned an ID from 0 to 31. The shape of Area is rectangle or circle. Area latitude, longitude, range, and ionospheric correction are transmitted from the QZSS.

Figure 6.1-1 shows the example of relationship between the transmitted data part of correction messages and the STEC coverage, when four AREA is defined in Region#10. See Section 6.2 and 6.3 for details of the message.

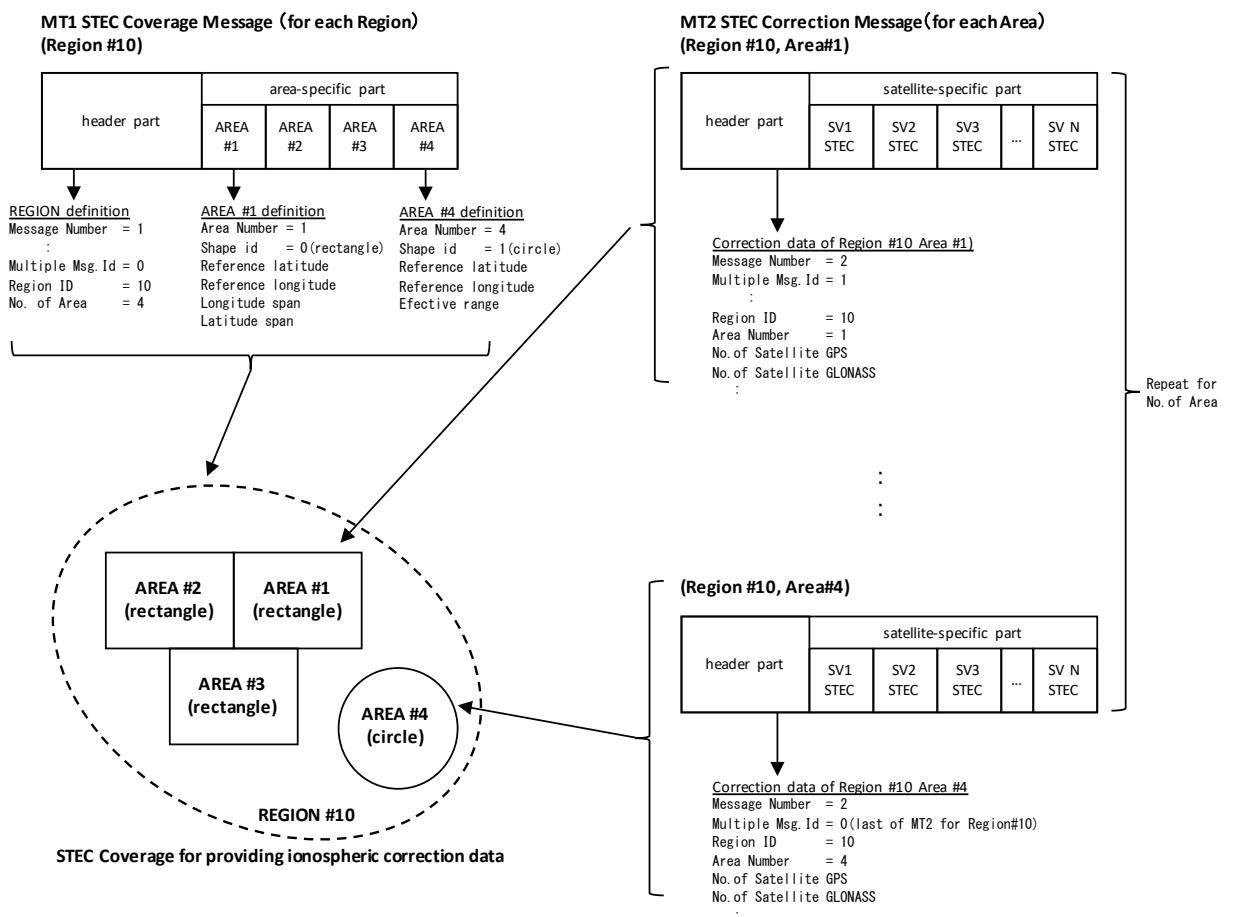

Figure 6.1-1 Example of Ionospheric correction message transmission

6.2 Message Structure

See Section 4.1 for Message Structure.

6.3 Message contents

6.3.1 Header Part

See Section 4.2.1 for Header Part.

6.3.2 Data Part

6.3.2.1 General

The data part of L6D Messages includes the Technology Demonstration Messages shown in Table 6.3.2-1. Note that these messages are MADOCA-PPP proprietary messages for Technology Demonstration purposes and are not official RTCM messages.

Table 6.3.2-1 Technology Demonstration Messages

Message Type	Sub Type	Message Name	No. of Bit ^(*1)	Section No.
1	0	STEC Coverage	$75 + (45 \times N_{\text{area}})$	6.3.2.2
2	0	STEC Correction	$77 + \{(26 \text{ or } 50 \text{ or } 60 \text{ or } 76) \times N_{\text{sat}(\text{sys})}\} \times N_{\text{sys}}$	6.3.2.3

(*1) N_{area} = No. of area of each STEC Region

$N_{\text{sat}(\text{sys})}$ = No. of augmented satellite of each GNSS

(1) Update Interval and Validity Period

Table 6.3.2-2 shows the nominal update interval and validity period for each message. Note that the user algorithm cannot rely on any specific transmission pattern because it may be changed in the future for reasons of performance improvement.

Table 6.3.2-2 Nominal Update Interval

Message Name	Message Type ID, Sub Type ID	Nominal Update Interval [s]
STEC Coverage	MT1, 0	60
STEC Correction	MT2, 0	60
Null Message	(N/A)	(N/A)

(2) Validity Period

Each message has a validity period based on each characteristic. Table 6.3.2-3 shows Validity Period of each message. Origin of the validity interval is exact second of QZSST that is sent in the header part of messages that contains the information (refer to the data field “GNSS Epoch Time 1s” and “GNSS Hourly Epoch Time 1s”). The data that exceeded the validity period can be used as an own risk, however note that the quality of data degradation.

Table 6.3.2-3 Validity Period

Message Name	Message Type ID, Sub Type ID	Validity Period [s]
STEC Coverage	MT1, 0	(*1)
STEC Correction	MT2, 0	300
Null Message	(N/A)	(N/A)

(*1) Validity interval of STEC Coverage is described in 6.3.2.2.

(3) Relationship among L6 Messages Transmitted by Each Satellite

Each satellite may transmit STEC Correction for different Regions. The user must select the applicable Region by receiving L6 message from all QZSS satellites that can be received from the user location.

6.3.2.2 MT1 - STEC Coverage Message

STEC Coverage message structure is shown Figure 6.3.2-1. The message header and area-specific part are defined in Table 6.3.2-4 and Table 6.3.2-5, respectively.

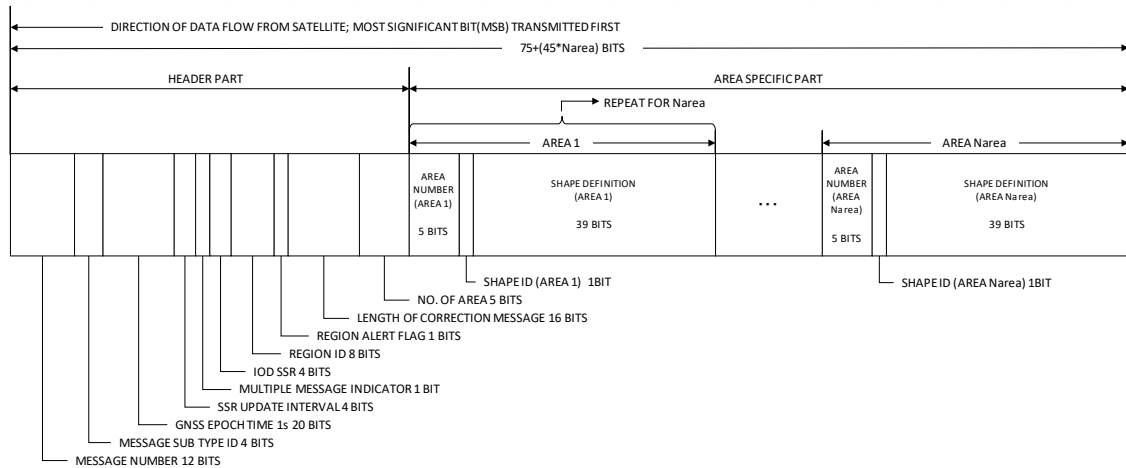

Figure 6.3.2-1 STEC Coverage definition Message structure

Table 6.3.2-4 Contents of message header, STEC Coverage Message

DF Name	DF Range	BIT	LSB	DF Unit	Note
Message Number	0-4095	12	-	-	1
Message Sub Type ID	0-15	4	-	-	0
GNSS Epoch Time 1s	0-604799	20	1	s	604800-1048575 indicates data not available
SSR Update Interval	0-15	4	1	-	
Multiple Message Indicator	0-1	1	-	-	
IOD SSR	0-15	4	-	-	
Region ID	0-255	8	-	-	
Region Alert flag	0-1	1	-	-	
Length of Correction Messages	0-65535	16	-	bit	
No. of Area	0-31	5	1		

Table 6.3.2-5 Contents of area-specific part, STEC Coverage Message

DF Name	DF Range	BIT	LSB	DF Unit	Note
Area Number (Area 1)	0-31	5	-	-	
Shape ID (Area 1)	0-1	1	-	-	
Shape definition (Area 1)	-	39	-	-	See Table 6.3.2-6
~	-				
Area Number (Area N _{area})	0-31	5	-	-	
Shape ID (Area N _{area})	0-1	1	-	-	
Shape definition (Area N _{area})	-	39	-	-	See Table 6.3.2-6

Table 6.3.2-6 Contents of shape definition

(i) Shape ID = 0

DF Name	DF Range	BIT	LSB	DF Unit	Note
Reference latitude	-89.9 - 89.9	11	0.1	deg	center latitude of rectangle area
Reference longitude	0.0 - 359.9	12	0.1	deg	center longitude of rectangle area
Latitude span	0 - 25.5	8	0.1	deg	
Longitude span	0 - 25.5	8	0.1	deg	

(ii) Shape ID = 1

DF Name	DF Range	BIT	LSB	DF Unit	Note
Reference latitude	-89.9 - 89.9	15	0.01	deg	center latitude of circle area
Reference longitude	0.0 - 359.99	16	0.01	deg	center longitude of circle area
Effective range	0 - 2550	8	10	km	

(1) Message Number

The message number is defined in Table 6.3.2-1.

(2) Message Sub Type ID

The message sub type ID is defined in Table 6.3.2-1.

(3) GNSS Epoch Time 1s

Seconds since the beginning of the GPS week. The data is defined in QZSST.

(4) SSR Update Interval

SSR Update Interval is used to indicate update interval of the parameter. The supported SSR update intervals are listed in Table 4.2.2-6.

(5) Multiple Message Indicator

Indicator for transmitting message with the same message number, sub type ID, Epoch Time and Region ID. "0": last message of a sequence, "1": multiple message transmitted.

(6) IOD SSR

A change of issue of data SSR is used to indicate a change in the STEC coverage SSR generating configuration. When the definition of the Region ID have been changed, the IOD SSR is counted up. The user should use STEC Coverage Message (MT1) and STEC Correction Message (MT2) with the same IOD SSR for each Region.

(7) Region ID

Region ID is the ID that segments the applicable range of STEC.

(8) Region Alert Flag

When the Region alert flag is set to "1"_(B), this indicates a situation which no STEC correction data in all Areas of the Region is available.

(9) Length of Correction Messages

This parameter is the total bit length of the STEC correction message (MT2) for this Region transmit following this STEC coverage message (MT1). User can use this parameter to skip to message of next Region, without decoding STEC correction messages of this Region.

(10) Area Number

Area Number is the number that divides the range within Region.

(11) Definition of applicable range

The applicable range of STEC is identified with the combination of Region ID and Area Number. Each range has either rectangle or circle shape, which defined in Shape ID and Shape definition parameters. Shape ID indicates the shape of the range. Shape ID 0 indicates a rectangle range, 1 indicates a circle range. Shape definition indicates the geographic range as shown in Figure 6.3.2-2.

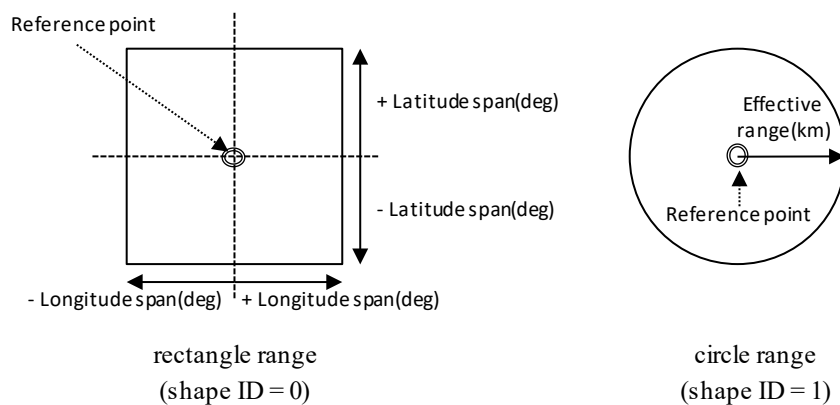

Figure 6.3.2-2 The definition of applicable range

6.3.2.3 MT2 - STEC Correction Message

STEC Correction message structure is shown Figure 6.3.2-3. The message header and satellite-specific part are defined in Table 6.3.2-7 and Table 6.3.2-8, respectively.

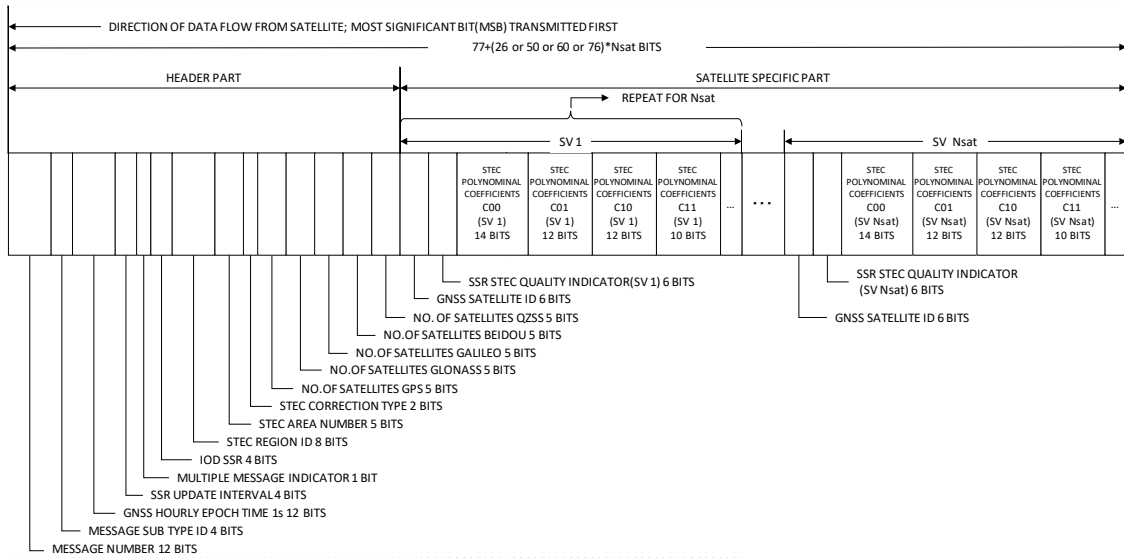

Figure 6.3.2-3 STEC Correction Message structure

Table 6.3.2-7 Contents of message header, STEC Correction Message

DF Name	DF Range	BIT	LSB	DF Unit	Note
Message Number	0-4095	12	-	-	2
Message Sub Type ID	0-15	4	-	-	0
GNSS Hourly Epoch Time 1s	0-3599	12	1	s	3600-4095 indicates data not available
SSR Update Interval	0-15	4	1	-	
Multiple Message Indicator	0-1	1	-	-	
IOD SSR	0-15	4	1	-	
STEC Region ID	0-255	8	-	-	
STEC Area Number	0-31	5	-	-	
STEC Correction Type	0-3	2	1	-	
No. of Satellites GPS	0-31	5	1	-	
No. of Satellites GLONASS	0-31	5	1	-	
No. of Satellites Galileo	0-31	5	1	-	
No. of Satellites BeiDou	0-31	5	1	-	0 (not supported)
No. of Satellites QZSS	0-31	5	1	-	

Table 6.3.2-8 Contents of satellite-specific part of STEC Correction Message

DF Name	DF Range	BIT	LSB	DF Unit	Note
STEC Correction(GPS SV 1)	-	-	-	-	See Table 6.3.2-9 Repeat for No. of Satellites GPS
~					
STEC Correction(GPS SV $N_{sat, gps}$)	-	-	-	-	
STEC Correction(GLONASS SV 1)	-	-	-	-	See Table 6.3.2-9 Repeat for No. of Satellites GLONASS
~					
STEC Correction(GLONASS SV $N_{sat, glo}$)	-	-	-	-	
STEC Correction(Galileo SV 1)	-	-	-	-	See Table 6.3.2-9 Repeat for No. of Satellites Galileo
~					
STEC Correction(Galileo SV $N_{sat, gal}$)	-	-	-	-	
STEC Correction(BeiDou SV 1)	-	-	-	-	See Table 6.3.2-9 Repeat for No. of Satellites BeiDou
~					
STEC Correction(BeiDou SV $N_{sat, bds}$)	-	-	-	-	
STEC Correction(QZSS SV 1)	-	-	-	-	See Table 6.3.2-9 Repeat for No. of Satellites QZSS
~					
STEC Correction(QZSS SV $N_{sat, qzs}$)	-	-	-	-	

Table 6.3.2-9 Contents of STEC Correction

(i) STEC Correction type = 0

DF Name	DF Range	BIT	LSB	DF Unit	Note
GNSS Satellite ID	0-63	6	1	-	
SSR STEC Quality Indicator	bits5-3:0-7 bits2-0:0-7	6	-	-	
STEC Polynomial Coefficients C_{00}	± 409.55	14	0.05	TECU	-409.6 indicates data not available

(ii) STEC Correction type = 1

DF Name	DF Range	BIT	LSB	DF Unit	Note
GNSS Satellite ID	0-63	6	1	-	
SSR STEC Quality Indicator	bits5-3:0-7 bits2-0:0-7	6	-	-	
STEC Polynomial Coefficients C_{00}	± 409.55	14	0.05	TECU	-409.6 indicates data not available
STEC Polynomial Coefficients C_{01}	± 40.94	12	0.02	TECU /deg	-40.96 indicates data not available
STEC Polynomial Coefficients C_{10}	± 40.94	12	0.02	TECU /deg	-40.96 indicates data not available

(iii) STEC Correction type = 2

DF Name	DF Range	BIT	LSB	DF Unit	Note
GNSS Satellite ID	0-63	6	1	-	
STEC Quality Indicator	bits5-3:0-7 bits2-0:0-7	6	-	-	
STEC Polynomial Coefficients C_{00}	± 409.55	14	0.05	TECU	-409.6 indicates data not available
STEC Polynomial Coefficients C_{01}	± 40.94	12	0.02	TECU /deg	-40.96 indicates data not available
STEC Polynomial Coefficients C_{10}	± 40.94	12	0.02	TECU /deg	-40.96 indicates data not available
STEC Polynomial Coefficients C_{11}	± 10.22	10	0.02	TECU /deg ²	-10.24 indicates data not available

(iv) STEC Correction type = 3

DF Name	DF Range	BIT	LSB	DF Unit	Note
GNSS Satellite ID	0-63	6	1	-	
STEC Quality Indicator	bits5-3:0-7 bits2-0:0-7	6	-	-	
STEC Polynomial Coefficients C_{00}	± 409.55	14	0.05	TECU	-409.6 indicates data not available
STEC Polynomial Coefficients C_{01}	± 40.94	12	0.02	TECU /deg	-40.96 indicates data not available
STEC Polynomial Coefficients C_{10}	± 40.94	12	0.02	TECU /deg	-40.96 indicates data not available
STEC Polynomial Coefficients C_{11}	± 10.22	10	0.02	TECU /deg ²	-10.24 indicates data not available
STEC Polynomial Coefficients C_{02}	± 0.635	8	0.005	TECU /deg ²	-6.4 indicates data not available
STEC Polynomial Coefficients C_{20}	± 0.635	8	0.005	TECU /deg ²	-6.4 indicates data not available

(1) GNSS Hourly Epoch Time 1s

Hours, minutes, and seconds part of GPS epoch time.

(2) No. of Satellites GNSS

This parameter indicates the number of satellites stored in the satellite-specific part for each GNSS.

(3) GNSS Satellite ID

This parameter indicates Satellite ID each GNSS, as listed in Table 6.3.2-10.

Table 6.3.2-10 GNSS Satellite ID

GNSS	Satellite ID
GPS	PRN code of the GPS Satellite.
GLONASS	Slot number of the GLONASS Satellite.
Galileo	PRN code of the Galileo Satellite.
QZSS	From 1 to 10 refer to PRN code of the QZSS Satellites. See Table 4.2.2-8.

(4) STEC correction type

STEC correction type for 0-3 as listed in Table 6.3.2-9.

(5) SSR STEC Quality Indicator

The bit assignment is the same as SSR URA. The STEC quality indicator is represented by a combination of STEC_URA_CLASS and STEC_URA_VALUE. The 3 MSBs define the STEC_URA_CLASS within a range of 0-7 while the 3 LSBs define the STEC_URA_VALUE within a range of 0-7.

The STEC URA is computed by:

$$\text{STEC URA [mm]} \leq 3^{\text{STEC_URA_CLASS}} \left(1 + \frac{\text{STEC_URA_VALUE}}{4} \right) - 1 \text{ [mm]}$$

Special cases are:

000 000 : STEC URA undefined/unknown

111 111 : STEC URA > 5466.5 [mm]

Note that the unit of STEC URA is mm, not TECU.

The STEC URA is used as statistical indicator (1 sigma) to describe the quality of STEC correction data. If the STEC URA exceeds the user defined threshold for each application, user receives can, for example, (a) discard the STEC Correction data, or (b) decrease the weight of the corresponding satellite observation in the positioning process.

(6) STEC Polynomial Coefficients (C_{00} , C_{01} , C_{10} , C_{11} , C_{02} , C_{20})

Coefficients are used to calculate STEC in a specific local area where Area Number is assigned in STEC Coverage message. Table 6.3.2-11 defines C_{00} , C_{01} , C_{10} , C_{11} , C_{02} , and C_{20} . Where φ is the latitude of the user, λ is the longitude of the user, φ_0 is the latitude of the reference, and λ_0 is longitude of the reference.

Table 6.3.2-11 Definition of STEC polynomial coefficients (C_{00} , C_{01} , C_{10} , C_{11} , C_{02} , C_{20})

STEC Correction Type	STEC Correction
0	$\text{STEC} = C_{00}$
1	$\text{STEC} = C_{00} + C_{01}(\varphi - \varphi_0) + C_{10}(\lambda - \lambda_0)$
2	$\text{STEC} = C_{00} + C_{01}(\varphi - \varphi_0) + C_{10}(\lambda - \lambda_0) + C_{11}(\varphi - \varphi_0)(\lambda - \lambda_0)$
3	$\text{STEC} = C_{00} + C_{01}(\varphi - \varphi_0) + C_{10}(\lambda - \lambda_0) + C_{11}(\varphi - \varphi_0)(\lambda - \lambda_0) + C_{02}(\varphi - \varphi_0)^2 + C_{20}(\lambda - \lambda_0)^2$

6.4 Transmission Pattern

STEC Coverage and Correction message for each Region are transmitted within 60 seconds. If there is no ionospheric correction data to be transmitted, set all bits of the data part to 0, and the subframe indicator in the L6 message type ID of this L6 message set to 1.

The transmission pattern are variable depending on the the transmitting satellite. The user must select the applicable Region by receiving L6 message from all QZSS satellites that can be received from the user location. Note that user algorithm not assumes any specific pattern.

6.5 User Algorithm

The STEC Correction Data transmitted from the L6D message is used in combination with the MADOCA-PPP SSR Correction data transmitted from the L6E message.

6.5.1 Calculation of Ionosphere Slant Delay Correction

6.5.1.1 Parameter

The STEC Correction message should be selected according to the area of the receiver position, when the receiver position is within the service area.

Table 6.5.1-1 lists the parameters defined in the STEC Correction message.

Table 6.5.1-2 lists the parameters required for the calculations.

The algorithms are same for GPS, GLONASS, Galileo and QZSS.

Table 6.5.1-1 STEC correction message parameters

Parameter	Definition	Unit
C_{00}	SSR ionosphere slant delay correction (MT2): Polynomial Coefficients C_{00}	TECU
C_{01}, C_{10}	SSR ionosphere slant delay correction (MT2): Polynomial Coefficients C_{01}, C_{10}	TECU/deg
C_{11}, C_{02}, C_{20}	SSR ionosphere slant delay correction (MT2): Polynomial Coefficients C_{11}, C_{02}, C_{20}	TECU/deg ²
φ_0	Reference latitude of selected area (MT1)	deg
λ_0	Reference longitude of selected area (MT1)	deg

Table 6.5.1-2 Other parameter

Parameter	Definition	Unit
f	Frequency	Hz

6.5.1.2 Algorithm

The ionosphere slant delay (STEC) consists of the polynomial part of the STEC correction message.

The ionosphere slant delay in area k for the satellite PRN is calculated as follows:

$$I_{k,fi}^{PRN} = \frac{40.31 \times 10^{16}}{f_i^2} \times STEC_k^{PRN}$$

where,

$STEC_k^{PRN}$ is calculated in accordance with the “STEC Correction Type” included in the STEC correction message, as follows:

STEC Correction Type = 0:

$$STEC_k^{PRN} = C_{00}^{PRN}$$

STEC Correction Type = 1:

$$STEC_k^{PRN} = C_{00}^{PRN} + C_{01}^{PRN}(\varphi - \varphi_0) + C_{10}^{PRN}(\lambda - \lambda_0)$$

STEC Correction Type = 2:

$$STEC_k^{PRN} = C_{00}^{PRN} + C_{01}^{PRN}(\varphi - \varphi_0) + C_{10}^{PRN}(\lambda - \lambda_0) + C_{11}^{PRN}(\varphi - \varphi_0)(\lambda - \lambda_0)$$

STEC Correction Type = 3:

$$STEC_k^{PRN} = C_{00}^{PRN} + C_{01}^{PRN}(\varphi - \varphi_0) + C_{10}^{PRN}(\lambda - \lambda_0) + C_{11}^{PRN}(\varphi - \varphi_0)(\lambda - \lambda_0) \\ + C_{02}^{PRN}(\varphi - \varphi_0)^2 + C_{20}^{PRN}(\lambda - \lambda_0)^2$$

with

φ, λ : User's location (Latitude, Longitude)

φ_0, λ_0 : Reference coordinate of the selected area (Latitude, Longitude) in MT1.

6.5.2 (Reference) Observation Equations

6.5.2.1 Parameter

Table 5.5.5-1 lists the parameters defined in Section 5.5.1 , 5.5.2 , 5.5.3 and 6.5.1 . These parameters are used for calculations of the pseudorange correction and the carrier-phase correction for the satellite PRN.

Table 6.5.2-1 Parameters

Parameter	Definition	Unit
$t_{satellite}^{PRN}$	Satellite clock corrected by Compact SSR GNSS Clock Correction message (see Section 5.5.1)	s
$\mathbf{x}_{orbit(ECEF)}^{PRN}$	Satellite ECEF position corrected by Compact SSR GNSS Orbit Correction message (see Section 5.5.2)	m
p^{PRN}	Pseudorange observation corrected by Compact SSR Code Bias message (see Section 5.5.3)	m
ϕ^{PRN}	Carrier-phase observation corrected by Compact SSR Phase Bias message (see Section 5.5.3)	cycle
I^{PRN}	Ionospheric slant delay by STEC Correction message (see Section 6.5.1)	m

6.5.2.2 Algorithm

The single frequency pseudorange and carrier-phase observations for the satellite PRN are related to the user position, clock, ionosphere, troposphere and ambiguity parameter according to the following simplified observation equations:

$$P_{f_i}^{PRN} = \rho^{PRN} + c(dT_{GNSS} - t_{satellite}^{PRN}) + I_{f_i}^{PRN} + T^{PRN} + \varepsilon_p^{PRN}$$

$$\Phi_{f_i}^{PRN} = \rho^{PRN} + c(dT_{GNSS} - t_{satellite}^{PRN}) - I_{f_i}^{PRN} + T^{PRN} + N_{f_i} \lambda_{f_i} + \varepsilon_\phi^{PRN}$$

where

$P_{f_i}^{PRN}$: pseudorange observation corrected by Compact SSR Code Bias message.
$\Phi_{f_i}^{PRN}$: carrier-phase observation corrected by Compact SSR Phase Bias message.
$(\lambda_{f_i} \phi_{f_i}^{PRN})$	
f_i	: frequency
λ_{f_i}	: wavelength of frequency f_i
dT_{GNSS}	: receiver clock offset of each GNSS from the QZSS
T^{PRN}	: tropospheric slant delay of the receiver
$I_{f_i}^{PRN}$: ionospheric slant delay of the receiver to the frequency f_i , calculated by STEC Correction message.
N_{f_i}	: ambiguity of the carrier-phase
$\varepsilon_p^{PRN}, \varepsilon_\phi^{PRN}$: relevant measurement noise components including multipath

ρ^{PRN} is the geometrical range computed by satellite position corrected by orbit correction $\mathbf{X}_{orbit(ECEF)}^{PRN} = (x_{orbit}^{PRN}, y_{orbit}^{PRN}, z_{orbit}^{PRN})$ and user position $(x_{user}, y_{user}, z_{user})$ as follow:

$$\rho^{PRN} = \sqrt{(x_{orbit}^{PRN} - x_{user})^2 + (y_{orbit}^{PRN} - y_{user})^2 + (z_{orbit}^{PRN} - z_{user})^2}$$

Note that the user receiver side specific compensations such as user site displacements, phase wind-up, user receiver antenna phase center offset (PCO), user receiver phase center variation (PCV), and quarter cycle carrier phase shifts which are described in 5.5.4 are not included in these observation equations. Users should apply the compensations to the GNSS observation data (both carrier phase and pseudo range) in the positioning calculation process.

Since the objective of the STEC correction is to shorten the initial convergence time, we recommend using STEC correction message provided by MADOCA-PPP with the following steps:

- Use the STEC correction message only from the start of positioning until convergence.
- After convergence, the ionospheric delay estimated by user's own processing should be used instead of the delay by the STEC correction message.
- To avoid discontinuities when switching the delay by the STEC correction message to the delay estimated by user's own processing, remove the bias between the delay by STEC correction message and the delay estimated by user's own processing.