

Quasi-Zenith Satellite System
Interface Specification
Centimeter Level Augmentation Service
(IS-QZSS-L6-008)

(Mar 18, 2026)

Cabinet Office

Disclaimer of Liability

The Cabinet Office, Government of Japan (“CAO”) and Quasi-Zenith Satellite System Services Inc. make the User Interface Specification (IS-QZSS) (“Document”) available to the public to promote the services using Quasi-Zenith Satellite System (“QZSS”) by development of receivers, applications and so on, and also are aiming for high accuracy and convenience with respect to satellite positioning services and message services of QZSS (collectively “Services”). The Services are freely available to any user. However, the receivers and/or applications developed based on this Document may not receive signals or may receive incorrect signals due to no warranty of the Services. You are therefore highly recommended to ensure appropriate measures to avoid accidents such as redundancy, backup and fail-safe, if you develop receivers and/or applications using the Services for the purpose that will possibly give an impact to human life, body and properties. The Services may be suspended or changed without prior notice in accordance with the decision by Government of Japan. This Document and the Services are available subject to the following terms and conditions. You may use this Document only if you agree to such terms and conditions. You shall be deemed to agree such terms and conditions by using this Document.

(1) With respect to this Document and the information included in this Document, the Cabinet Office, Government of Japan (“CAO”) and Quasi-Zenith Satellite System Services Inc. (“QSS”) disclaim all warranties of any kind, express or implied, including but not limited to, the followings:

- i) warranty of accuracy, completeness, usefulness, and fitness for a particular request or purpose;
- ii) warranty that this Document and the information included in this Document will not be changed in to the future; and
- iii) warranty that this Document and the information included in this Document do not infringe any third party’s intellectual property rights.

(2) With respect to satellite positioning services and message services (collectively “Services”), CAO and QSS disclaim all warranties of any kind, express or implied, from any cause whether it is related to Quasi-Zenith Satellite System, other outside systems or not, including but not limited to, the followings:

- i) warranty as to service area, accuracy, availability, continuity, and integrity described in this Document;
- ii) warranty of usefulness, and fitness for a particular request or purpose; and
- iii) warranty that the use of Services does not infringe any third party’s intellectual property rights.

(3) To the extent permitted by applicable laws, CAO and QSS shall not be responsible and liable for any damages and losses, including but not limited to, direct, indirect, incidental, special or consequential damages, whether under contractual liability, product liability, strict liability, tort liability or otherwise (including intent or negligence), caused by the use of this Document, the information included in this Document and the Services, the inability to use the Services, or the change of this Document and the information included in this Document.

Revision History

Rev. No.	Date	Page	Revisions		
001 Draft Edition	March 25, 2016		Draft edition		
	July 12, 2016	-	Adds Disclaimer of Liability		
	March 28,2017	1		Adds description of Centimeter Level Augmentation Service for Experiment	
		2		Fixed applicable document (1), (3) Adds reference document (5), (6)	
		20		Corrects description of (3) L6 Message Type ID Updates Message Generation Facility ID in Table 4.1.2-2	
		22		Updates No. of Bit for Compact SSR GNSS Satellite Code and Phase Bias Message	
		24		Fixed the definition of (5) multiple message indicator	
		34-37		Updates header of MT4073,6	
		39-40		Corrects DF range of C00 in MT4073,8	
		65-68		Adds subsection for L6E message.	
		September 15,2017	2		Fixed applicable document (3) Adds reference document (5), (6)
			34-36		Updates data structure of header part for Compact SSR GNSS Satellite Code and Phase Bias Message in Figure 4.1.2-8 and Table 4.1.12-19~20
	40			Adds description of SSR STEC Quality Indicator in 4.1.2.2.9 (4) Corrects description of λ_0 in 4.1.2.2.9 (5)	
	43			Adds description for Tropospheric Delay Quality Indicator Adds definition for constant offset of tropospheric wet vertical delay in 4.1.2.2.10 (5)	
	45-51			Updates nominal transmission pattern in Table 4.1.2-30	
	58-63			Updates definition of GRID in Table 4.1.4-1 Adds a support file " <i>clas_grid.def</i> " as appendix	
	73			Adds description for reference table of the SSR troposphere quality indicator	
	79			Adds subsection of GNSS Code/Phase Bias	
	81, 83			Adds description for interpolation method	
	82-83			Adds troposphere vertical delay wet variation value term Fixed subscript of mapping function	
	April 3,2018	84		Adds subsection for user dependent errors	
		2		Updates applicable document (3) Replaces reference document (8) with an updated one. Adds reference document (9)	
		3-4		Adds contents of section 2.3 and 2.4	
		20		Adds description to clarify the meaning of nominal validity period in 4.1.1.2 (4)	
		23		Changes the PPP-RTK from RTK-PPP	
		22, 69		Corrects description of subframe indicator in Table 4.1.2-2 and 4.2.2-2	
24			Adds description for user algorithm in 4.1.2.2.1		
28			Updates Compact SSR signal mask in Table 4.1.2-9		

Document subject to the disclaimer of liability

		33	Adds description for Compact SSR Code Bias in 4.1.2.2.5 (1)		
		49-54	Updates Subtype transmission pattern in Figure 4.1.2-12		
		60-65	Updates definition of GRID (Table 4.1.4-1 Compact network ID and coordinates)		
		68, 70	Updates reference source page of reference document (8)		
		71	Adds description for integrity information		
		80	Adds description regarding velocity calculation of a GEO satellite		
		81-82	Adds description of rigorous compensating method for “Network Bias correction” Remove description for phase wind up from section 5.5.3.2 to 5.5.6		
		84, 86	Adds description of interpolation/extrapolation method with three grids		
		87	Adds description for receiver inter system bias in 5.5.5.6		
		88	Adds subsection for calculation of Observation Space Representation in 5.5.5.7		
		August 31,2018	19	Adds Nominal Update Interval of Compact SSR GNSS Combined Correction in Table 4.1.1-1	
			20	Adds Nominal Validity Period of Compact SSR GNSS Combined Correction in Table 4.1.1-2	
			24	Adds Sub type 11, and updates Sub Type 6 in Table 4.1.2-3	
			47,48	Adds subsection for Sub Type 11 in 4.1.2.2.12	
			49-55	Updates Sub Type transmission pattern in 4.1.2.2.13	
			62-67	Updates definition of GRID (Table 4.1.4-1 Compact network ID and coordinates) Updates a support file “ <i>clas_grid.def</i> ”	
			84	Fixed equation of $\delta BIAS$ ’ calculation	
		001	November 5, 2018	87	Adds note for STEC Network correction
				2	Updates applicable document (3)
22	Adds description of user algorithm for different Message Generation Facility ID				
46	Corrects total data size in Figure 4.1.2-12				
48-54	Updates Sub Type transmission pattern in 4.1.2.2.13				
55	Adds description for validity interval				
61-66	Updates definition of GRID (Table 4.1.4-1 Compact network ID and coordinates) Updates a support file “ <i>clas_grid.def</i> ”				
72	Adds description for usage of integrity information in 5.4				
002	December 27, 2019	86	Corrects suffix of equation of ionosphere slant delay in 5.5.4.2		
		2	Updates document version of applicable document (3)		
		3	Adds items in terms and definitions		
		20, 21, 25	Adds Sub Type 12 in Table 4.1.1-1~2, 4.1.2-3		
		23	Corrects description of user algorithm for different Vender ID and Message Generation		

Document subject to the disclaimer of liability

			Facility ID
		25, 33, 35, 37	Unifies abbreviation for the number of signals “N _{sig} ” in Table 4.1.2-3, Figure 4.1.2-6~8
		28, 31	Adds definition for BeiDou in Table 4.1.2-8, 12
		42, 43	Fixed STEC Correction Type 3 in 4.1.2.2.9
		47, 48	Adds description for Service Information Message in 4.1.2.2.11
		51-57, 96-97, 99	Adds description for Compact SSR Atmospheric Correction
		58-64	Updates Sub Type transmission pattern in 4.1.2.2.14
		72, 76	Corrects coordinates in Table 4.1.4-1
		82	Corrects superscript of ranging error formula in 5.4
		94	Adds note in Table 5.5.3-1
003	August 20, 2020	56	Adds description for Tropospheric Correction Availability
004	July 14, 2021	15, 18	Specifies non-standard cord in Table 3.2.1-1 and Table 3.2.2-2
		71, 76	Deletes Compact Network ID 13 or more from “definition of GRID” Updates a support file “ <i>clas_grid.def</i> ”
		81	Updates definition of coordinate
005	September 9, 2022	1	Excluded regarding Centimeter Level Augmentation Service for Experiment (L6E) in the scope of this document
		2	Obsoletes Reference Documents (7) and (8) Updates document version of Reference Document (9)
		6-7, 11-14	Adds QZSS Block III satellite specification
		7	Updates annotation in Table 3.1.1-5
		24	Corrects the first bit of SIBFRAME in Figure 4.1.2-2
		26	Corrects the bits of GNSS ID in Figure 4.1.2-3
		28	Corrects satellite ID for QZSS in Compact SSR Satellite mask
		39	Corrects message name of Sub Type 7
77	Obsoletes the section 4.2 since L6E message is defined in dedicated interface specification documents, IS-QZSS-MDC and IS-QZSS-SAS		
006	January 21, 2025	2	Updates the revision of (1) in the reference documents
		6-8,10-16,18	Obsoletes the description about Block I and L6I
		15	Obsoletes the Remarks of the first row of Table 3.2.1-1
		20	Adds Compositions of Augmented Satellites in 4.1.1.2
		24	Updates the L6 Message Type ID in 4.1.2.1(3)
		26	Corrects the number of bits of the Compact SSR STEC Correction in table 4.1.2-3 to include the case of STEC correction type=3.
		27	Corrects the bit of the GNSS ID in Figure 4.1.2-3
41	Corrects the number of bits to include the case of STEC correction type=3 in Figure 4.1.2-10.		

Document subject to the disclaimer of liability

			Specifies the number of bits can be changed in Figure 4.1.2-10 to comply with Table 4.1.2-24 according to the value of STEC correction type.
		45	Corrects the bit of the STEC residual correction in Figure 4.1.2-11 to consist with Table 4.1.2-27.
		52	Corrects the bit of the SSR update interval in Figure 4.1.2-15 to consist with Table 4.1.2-35.
		53-54	Corrects the DF Ranges of Troposphere Residual offset in Table 4.1.2-36.
		57	Updates the STEC Correction Availability in 4.1.2.2.13(2)
		100, 101	Adds description for the algorithm in 5.5.7.2
007	July 31, 2025	20	Updates the description for Compositions of Augmented Satellites in 4.1.1.2
		24	Updates the L6 Message Type ID in 4.1.2.1(3)
		25	Corrects wording in 4.1.2.2.1 for clarity.
		29	Updates the definition of IOD SSR in 4.1.2.2.2 (6)
		67	Corrects the title of 4.1.2.3 (2)
		98	Updates the wording of the parameter definition in Table 5.5.5-2 for clarity.
		101,102	Updates the description for the algorithm in 5.5.7.2
008	Mar 18, 2026	80	Updates definition of coordinate.

"TBD" is an abbreviation for "To be determined." Those items marked "TBD" have not yet been determined but will be determined in the future.

Table of Contents

1. Scope	1
2. Reference and Terminology	2
2.1. Applicable Documents	2
2.2. Reference Documents	2
2.3. Terms and Definitions	3
2.4. Abbreviation.....	3
3. Signal Properties	6
3.1. RF Signal Characteristic.....	6
3.1.1. Signal Structure	6
3.1.2. Frequency	7
3.1.3. Configurations.....	8
3.1.3.1 L6 Signal Configuration	8
3.1.3.2 Signal Timing	10
3.1.4. Correlation Loss	11
3.1.5. Carrier Phase Noise	11
3.1.6. Spurious Characteristics	12
3.1.7. Phase Relationships Between the Signals	12
3.1.8. Minimum Received Power Level.....	12
3.1.9. Polarization Characteristics	12
3.1.10. Group Delay	13
3.1.10.1 PRN Code Phase Relationships Between Signals	13
3.1.10.2 Phase Relationships within the Frequency Band.....	13
3.1.11. PRN Code Jitter.....	13
3.1.12. Code Carrier Coherency (Phase Relationship between PRN Code and Carrier Wave).....	13
3.1.13. Antenna Phase Center Characteristics	13
3.1.14. Comparison of Block I, II and III RF Characteristics (Reference).....	14
3.2. PRN Code.....	15
3.2.1. PRN Number Assignments.....	15
3.2.2. L6 Code Generation	15
3.2.3. Non-Standard Code	18
4. Message Format	19
4.1. L6 Message (Centimeter-Level Augmentation Service Message)	19
4.1.1. Message Structure	19
4.1.1.1 General	19
4.1.1.2 Timing	20
4.1.2. Message contents.....	23
4.1.2.1 Header Part.....	23
4.1.2.2 Data Part.....	25

4.1.2.3 Null Message.....	67
4.1.3. FEC Encoded Algorithm	67
4.1.4. Definition of GRID	73
4.2. L6E Message (obsolete).....	79
5. User Algorithms	80
5.1. Time System.....	80
5.2. Geodetic Datum.....	80
5.2.1. Ellipsoid	80
5.2.2. Coordinate	80
5.2.3. Relationship with Japanese Geodetic Datum 2011	80
5.3. Constants	81
5.3.1. Speed of Light	81
5.3.2. Circular Constant.....	81
5.3.3. Angular Velocity of the Earth's Rotation.....	81
5.3.4. Earth's Gravitation Constant	81
5.3.5. Semi-circle	81
5.4. Integrity	81
5.4.1. Alert Flag.....	82
5.4.2. SSR URA	83
5.4.3. Atmosphere Correction Quality Indicator	86
5.4.4. Null Message.....	88
5.5. Calculation Algorithms for Compact SSR	89
5.5.1. Calculation of GNSS Clock Correction	89
5.5.1.1 Parameter.....	89
5.5.1.2 Algorithm	89
5.5.2. Calculation of GNSS Orbit Correction.....	91
5.5.2.1 Parameters	91
5.5.2.2 Algorithm	92
5.5.3. Calculation of GNSS Code/Phase Bias	93
5.5.3.1 Parameter.....	93
5.5.3.2 Algorithm	93
5.5.4. Calculation of Ionosphere Slant Delay Correction.....	95
5.5.4.1 Parameters	95
5.5.4.2 Algorithm	95
5.5.5. Calculation of Troposphere Delay Correction.....	98
5.5.5.1 Parameters	98
5.5.5.2 Algorithm	98
5.5.6. (Reference) User dependent errors.....	100
5.5.7. (Reference) Calculation of Observation Space Representation.....	101
5.5.7.1 Parameters	101
5.5.7.2 Algorithm	101

1. Scope

This interface specification document describes the interface specification between the Quasi-Zenith Satellite System (QZSS) and users of the Centimeter-Level Augmentation Service (CLAS). The interface specification includes the signal characteristic, message specification, and user algorithm.

The service introduction and the performance characteristics such as the service area, accuracy, availability, continuity and integrity are described in the applicable document (1) PS-QZSS, Performance Standard of QZSS.

2. Reference and Terminology

2.1. Applicable Documents

The cited parts of the following documents are recognized as being part of this document. This document may be updated when these applicable documents are updated.

- (1) PS-QZSS, Quasi-Zenith Satellite System Performance Standard.
- (2) RTCM STANDARD 10403.2 DIFFERENTIAL GNSS (GLOBAL NAVIGATION SATELLITE SYSTEMS) SERVICE –VERSION3, RTCM SPECIAL COMMITTEE NO.104, 1-FEB-2013.
- (3) RTCM Paper, Specification of Compact SSR Messages for Satellite Based Augmentation Service, Version 0.8, 17-SEP-2019.

2.2. Reference Documents

The following documents are referred on the creation of this document. This document might be updated when these reference documents are updated.

- (1) Global Positioning Systems Directorate Systems Engineering & Integration Interface Specification IS-GPS-200, Navstar GPS Space Segment/Navigation User Interfaces, Revision N 22-AUG-2022
- (2) Survey Act (Act No. 188 of June 3, 1950, Japan)
- (3) Working Rules for Operating Specifications (Notice 413, Ministry of Land, Infrastructure, Transport and Tourism, 2008)
- (4) Niell, A. E., Global mapping functions for the atmosphere delay at radio wavelengths, J. Geophys. Res., 101, 3227-3246, 1996.
- (5) Wu, J.T., S.C. Wu, G.A. Hajj, W.I. Bertiger, S.M. Lichten., Effects of Antenna Orientation on GPS Carrier Phase, Manuscripta Geodaetica, 18, 91-98, 1993.
- (6) G.Petit and B.Luzum (eds.), IERS Technical Note No.36, IERS Conventions (2010), 2010.
- (7) obsolete
- (8) obsolete
- (9) Multi GNSS survey manual (draft) - Utilization of modernized GPS, Galileo etc. - Commentary, Geospatial Information Authority of JAPAN (GSI), 2020

2.3. Terms and Definitions

Terms	Definitions
alert flag	See Section 5.4.1 If the service stops due to an error occurring in the ground or satellite system, an alert flag is notified to the user that the service is not available.
L6 message	See Section 4.1.1.1 A message transmitted by L6 signal, consisting of a 49-bit header, a 1695-bit data part, and a 256-bit Reed-Solomon code. The message is transmitted in one second.
frame	See Table 4.1.2-2 Multiple subframe. The number of subframe depends on an update interval of each Compact SSR message and a number of networks. For CLAS, frame consist of 5 subframe (30 successive data parts of L6 message).
subframe	See Table 4.1.2-2 Successive data parts of L6 message from 1 to 0 of multiple Message Indicator
Compact SSR message	See Section 4.1.2.2 Bandwidth efficient State Space Representation (SSR) format message for Precise Point Positioning - Real Time Kinematic (PPP-RTK) service defined as a proprietary message in the applicable document (2). Compact SSR messages are included in the data part of L6 message.
PPP-RTK	PPP-RTK is a conventional RTK using range corrections converted from SSR messages, which is defined in applicable document (3). Note that this method is called RTK-PPP in (2).

2.4. Abbreviation

-A-

-B-

bps bits per second

BPSK Binary Phase Shift Keying

-C-

CDMA Code Division Multiple Access

CLAS Centimeter Level Augmentation Service

CSK Code Shift Keying

CSSR Compact State Space Representation

-D-

-E-

ECEF Earth Centered Earth Fixed

-F-

-G-

GEO Geostationary Orbits

GEONET GNSS Earth Observation Network System

GLONASS Global Navigation Satellite System

GNSS Global Navigation Satellite System

Document subject to the disclaimer of liability

GPS	Global Positioning System
GPST	GPS Time
GRS	Geodetic Reference System
GSI	Geospatial Information Authority of Japan
-H-	
-I-	
IGS	International GNSS Service
IOD	Issue Of Data
IODE	Issue of Data Ephemeris
ITRF	International Terrestrial Reference Frame
I/NAV	Integrity Navigation Message
-J-	
JGD	Japanese Geodetic Datum
-K-	
-L-	
LNAV	Legacy NAVigation
LSB	Least Significant Bit
-M-	
MCS	Master Control Station
MDC	Multi-GNSS Advanced Orbit and Clock Augmentation
MSB	Most Significant Bit
MT	Message Type
-N-	
-O-	
OSR	Observation Space Representation
-P-	
PPP-RTK	Precise Point Positioning - Real-Time Kinematic
PRN	Pseudorandom Noise
-Q-	
QZO	Quasi-Zenith Orbits
QZS	Quasi-Zenith Satellite
QZSS	Quasi-Zenith Satellite System
QZSST	QZSS Time
-R-	
RMS	Root Mean Square
RS	Reed-Solomon
RTCM	Radio Technical Commission for Maritime Services
RTK-PPP	Real-Time Kinematic - Precise Point Positioning
-S-	
SAS	Signal Authentication Service
SIR-URE	Signal-In-Reference User Range Error
sps	symbols per second

SSR	State Space Representation
ST	Sub Type
STEC	Slant Total Electron Content
SV	Space Vehicle
-T-	
TAI	International Atomic Time
-U-	
URA	User Range Accuracy
-V-	
-W-	
-X-	
-Y-	
-Z-	

3. Signal Properties

3.1. RF Signal Characteristic

3.1.1. Signal Structure

Table 3.1.1-1 is obsoleted due to the termination of QZS1. Table 3.1.1-2 define the signal structure. Table 3.1.1-3 is obsoleted due to the termination of QZS1. Table 3.1.1-4 list the PRN code characteristics. Table 3.1.1-5 lists the message characteristics.

Table 3.1.1-1 obsoleted

Table 3.1.1-2 Signal structure (Block II and III)

Frequency band	Signal name	Modulation	PRN code name	Overlay code name	Message name
L6	L62	BPSK *1	L6 (code 1)	-	L6D
			L6 (code 2)	-	L6E

*1: This bit string is generated by two types of bit strings, *code 1* and *code 2* (corresponding to two channels), that are selected alternately in a chip-by-chip multiplexing.

Table 3.1.1-3 obsoleted

Table 3.1.1-4 PRN code characteristics (Block II and III)

PRN code name	Chip rate	Length	Period	Overlay code
L62 (code 1)	2.5575 Mcps	10,230 chip	4 ms	-
L62 (code 2)	2.5575 Mcps	10,230 chip	4 ms	-

Table 3.1.1-5 Message characteristics

Message name	bit rate	Symbol rate	Period (minimum frame size)	Coding system
L6D	2,000 bps	250 sps	1 s	RS (255,223)
L6E*1	2,000 bps	250 sps	1 s	RS (255,223)

*1 Block II and III

3.1.2. Frequency

Table 3.1.2-1 shows the frequency and bandwidth. The operational QZS frequency, f_s , is offset with respect to the reference frequency of $f_0 = 10.23$ [MHz], in order to provide compensation for the relativistic effect to which the QZS satellites are subjected due to their orbital motion. The frequency is as follows: L6 band offsets -0.690397Hz.

Table 3.1.2-1 Frequency and bandwidth

Frequency band	Block II and III
L6 band nominal center frequency : $1278.75 \text{ MHz} = 125 \times f_0$	42.0 MHz (± 21.0 MHz)

3.1.3. Configurations

3.1.3.1 L6 Signal Configuration

Figure 3.1.3-1 is obsoleted due to the termination of QZS1.

As shown in Figure 3.1.3-2, the L6 baseband signal is generated with a chipping rate of 5.115 Mchip/s by interleaving the following two 2.5575-Mcps bit streams.

For L61, the two streams consist of a 4-ms PRN short code modulated by means of code shift keying (CSK) by the Reed-Solomon encoded navigation message, and a 410-ms PRN long code modulated by a square wave with a period of 820 [ms], beginning from 0 ("010101...").

For L62, the two streams consist of two 4-ms PRN short codes modulated by means of code shift keying (CSK) by the Reed-Solomon encoded messages.

As defined in Figure 3.1.3-3, CSK modulation shifts the phase of the PRN code by the number of chips indicated by the 8-bit encoded navigational message symbol.

Figure 3.1.3-1 obsoleted

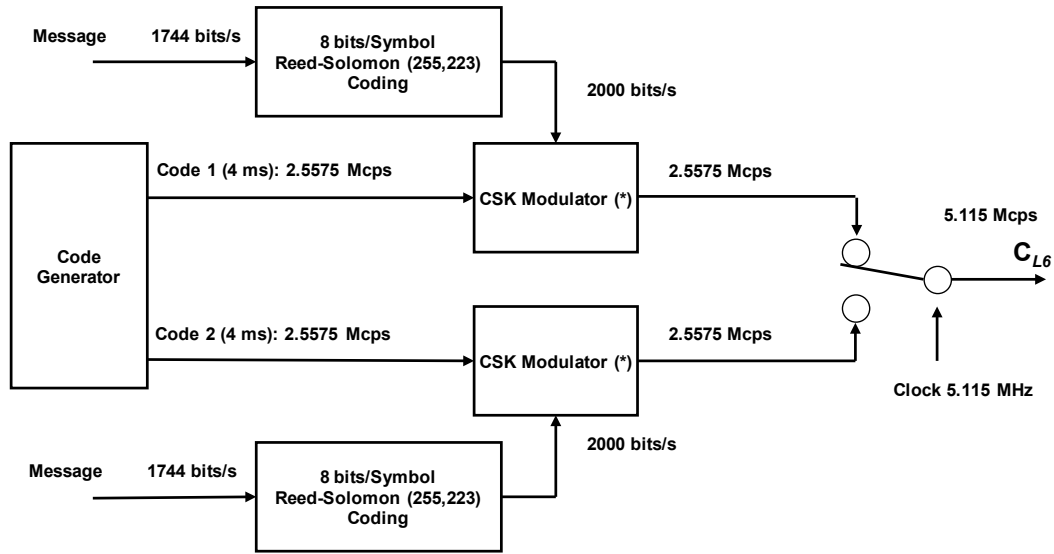

(*) Definition of Code Shift Keying (CSK) Modulation

Figure 3.1.3-2 L62 Signal structure

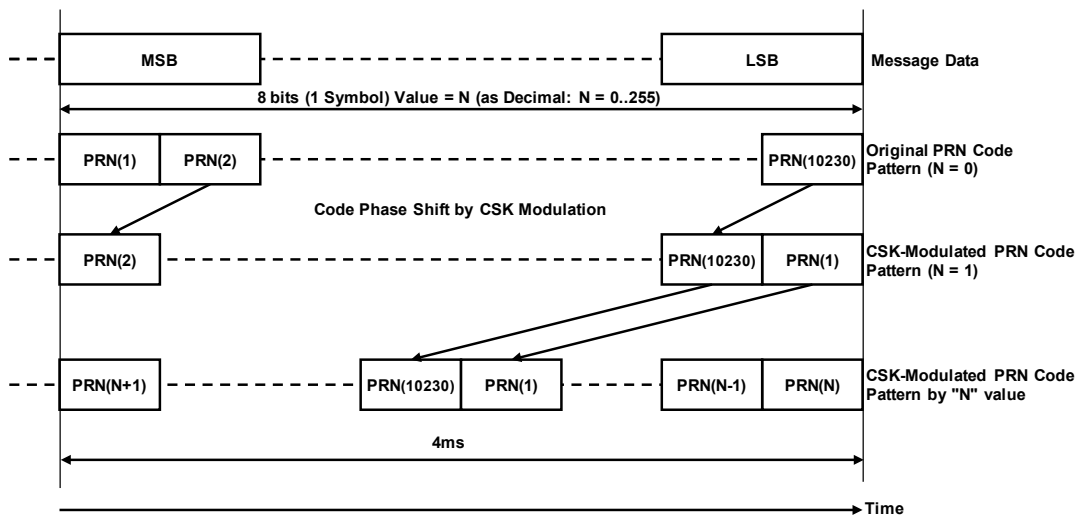

Figure 3.1.3-3 CSK modulation

3.1.3.2 Signal Timing

Figure 3.1.3-4 is obsolete due to the termination of QZS1.

For L62, the initialization period for the code generators are 4 ms for both the Code 1 generator and Code 2 generator. Figure 3.1.3-5 shows the timing relationship between Code 1 and Code 2.

Figure 3.1.3-4 obsolete

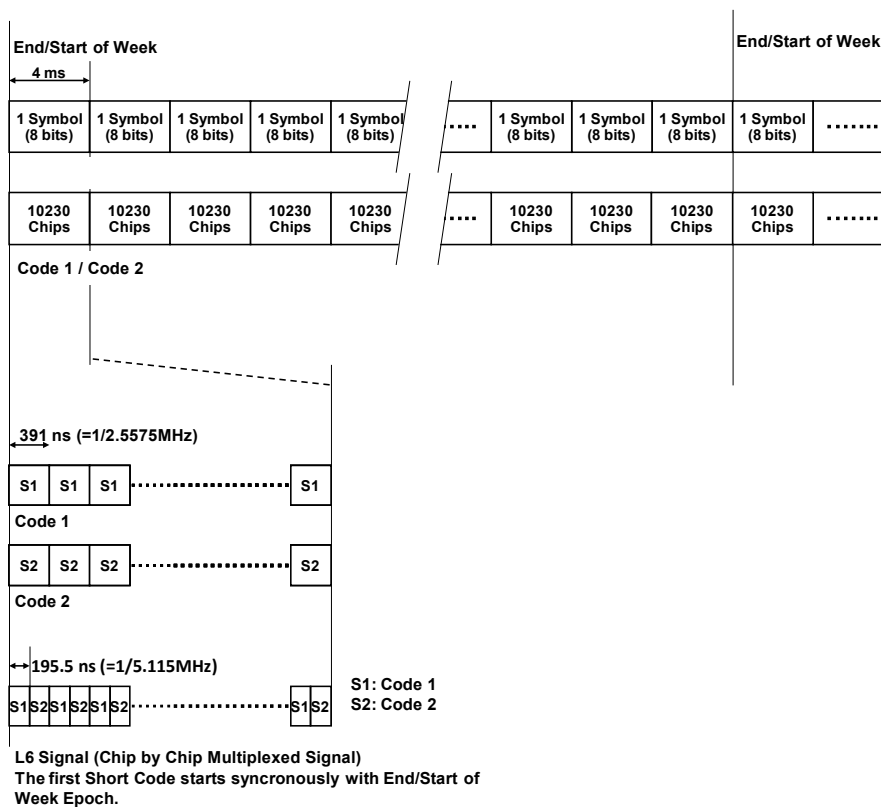

Figure 3.1.3-5 Signal timing (L62)

3.1.4. Correlation Loss

Correlation loss is defined as the difference between the theoretical demodulated (de-spread) power level and the output signal power level. The correlation loss values have the following levels.

Block II and III: 0.6 dB or less

3.1.5. Carrier Phase Noise

The spectrum density of the carrier phase noise for an un-modulated signal is of a level in which the tracking error of the carrier in a phase-locked loop (PLL) with a 10-Hz single-sided bandwidth is less than the following value:

Block II and III: 0.1 rad (RMS)

3.1.6. Spurious Characteristics

Any spurious transmissions shall be of less than the following value of the power level of the unmodulated carrier wave.

Block II and III : -40 dB or less

3.1.7. Phase Relationships Between the Signals

N/A (L6 signal is BPSK modulation.)

3.1.8. Minimum Received Power Level

A ground-based isotropic antenna with a gain of 0 dBi for circularly polarized wave reception is provided and, when the signals are received from a satellite with an elevation angle of 10° or more, the received power must not be less than the value indicated in Table 3.1.8-1.

Table 3.1.8-1 Minimum received power level

Signal	Block II and III
L6	-156.82 dBW (Total power of Code 1 and Code 2)

3.1.9. Polarization Characteristics

The L6 signal is right-hand circularly polarized.

Table 3.1.9-1 shows the axial ratio (power ratio of the long axis to the short axis) of the QZS circularly polarized waves, in a beam range of ± 10° from the boresight direction.

Table 3.1.9-1 Axial ratio (power ratio of long axis to short axis)

Signal	Block II and III
L6	No more than 2.0 dB

3.1.10. Group Delay

3.1.10.1 PRN Code Phase Relationships Between Signals

The PRN code phase differences between the QZS signals at the antenna phase center shall not exceed the values listed in Table 3.1.10-1. The maximum allowable fluctuations in the phase differences are listed in Table 3.1.10-2.

Table 3.1.10-1 Differences in pseudo random noise (PRN) code phases between signals

Signal	Block II	Block III
L6-L1	35 ns	35 ns
L6-L2	15 ns	—
L6-L5	20 ns	20 ns

Table 3.1.10-2 Fluctuation in phase difference

Block II and III
2 ns (3σ)

3.1.10.2 Phase Relationships within the Frequency Band

Not defined. Because the L6 signal consists of two codes (Code 1 and Code 2) that are time division multiplexed.

3.1.11. PRN Code Jitter

The jitter of the PRN code shall not exceed 2.0 ns for a value of 3σ .

Moreover, the mean value of the difference between the rising edge delay (or advance) and the falling edge shall not exceed 1.0 ns.

3.1.12. Code Carrier Coherency (Phase Relationship between PRN Code and Carrier Wave)

The fluctuations in the difference between the PRN code phase and the carrier wave phase at the antenna phase center for signals shall not exceed 1.2 ns.

3.1.13. Antenna Phase Center Characteristics

Not defined

3.1.14. Comparison of Block II and III RF Characteristics (Reference)

A comparison of the Block II and III RF characteristics is given in Table 3.1.14-1.

Table 3.1.14-1 Comparison table of Block II and III RF characteristics

No.	Item	QZSS Block II	QZSS Block III
1	Correlation loss	0.6 dB	0.6 dB
2	Carrier phase noise	0.1 rad(RMS)	0.1 rad(RMS)
3	Spurious characteristics	-40 dBc	-40 dBc
4	Phase relation	N/A	N/A
5	Minimum received power level	-156.82 dBW	-156.82 dBW
6	Polarization characteristics	2.0 dB	2.0 dB
7	Group delay (Absolute value of among the signals) *	L6-L1: 35 ns L6-L2: 15 ns L6-L5: 20 ns	L6-L1: 35 ns L6-L5: 20 ns
8	Fluctuation of group delay between the frequency	2.0 ns (3 σ)	2.0 ns (3 σ)
9	Fluctuation of group delay in the identical frequency	N/A	N/A
10	Phase relationships within the frequency band	N/A	N/A
11	PRN code jitter	2.0 ns (3 σ)	2.0 ns (3 σ)
12	Coherency of code carrier	1.2 ns	1.2 ns
13	Antenna phase center special quality	N/A	N/A

*Value at the transmitting antenna of the satellite.

When using the L1 signal timing to acquire the L6 signal, it is necessary to consider the propagation delay and the internal delay in the receiver design.

3.2. PRN Code

3.2.1. PRN Number Assignments

Table 3.2.1-1 lists the PRN numbers and satellites types.

Table 3.2.1-1 PRN numbers and satellite types

PRN (Code1)	PRN (Code2)	Satellite types	Remarks
193	203	QZO	
194	204	QZO	
195	205	QZO	
196	206	QZO	
197	207	QZO	
198	208	QZO	Used as a non-standard code
199	209	(Q)GEO	
200	210	(Q)GEO	
201	211	(Q)GEO	
202	212	(Q)GEO	Used as a non-standard code

3.2.2. L6 Code Generation

Separate 20-bit stage code generators are used to generate the two code patterns (Code 1 and Code 2). The satellite numbers (PRN numbers) are identified by the default settings for each of these code generators.

Figure 3.2.2-1 is obsoleted due to the termination of QZS1.

For L62, as shown in Figure 3.2.2-2, the L62 signal code consists of a Kasami series Code 1 (2.5575 Mcps) and Code 2 (2.5575 Mcps). Both codes have a 10,230 chip length and a 4-ms period.

Figure 3.2.2-1 obsolete

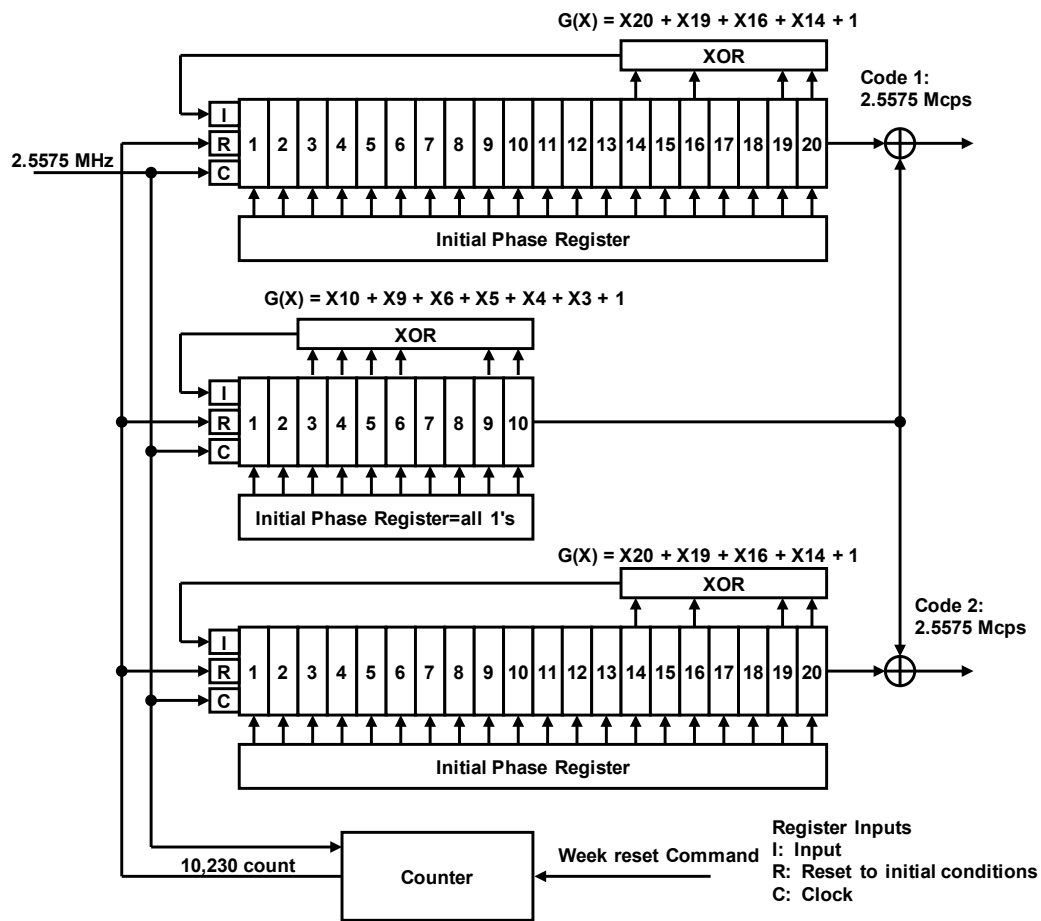

Figure 3.2.2-2 Block diagram of code generation (L62)

Table 3.2.2-1 obsolete

Table 3.2.2-2 L6 code phase assignment (L62)

Code 1			Code 2		
PRN No.	Initial Shift Register State (Octal)	End Shift Register State (Octal)	PRN No.	Initial Shift Register State (Octal)	End Shift Register State (Octal)
193	0255021	3766050	203	1142153	0765516
194	0327455	1277740	204	1723711	3617751
195	0531421	0407113	205	3672765	0454615
196	0615350	0223234	206	0030404	2147760
197	0635477	1761450	207	0000546	0753651
198	1547457	0325503	208	1306224	1210414
199	1715254	2675565	209	3642512	1417417
200	1741247	1374150	210	0255043	3450571
201	2322713	1534774	211	2020075	1617410
202	2534561	1610215	212	3571777	1240160

* 198/208/202/212: It is possible to use non-standard code.

The first digit in the octal notation represents the first two chips (i.e. The most significant "0" in the binary notation shall be ignored)

For example: In the case of '1741247' in octal notation, the first 20 chips are '01 111 100 001 010 100 111' in binary notation.

3.2.3. Non-Standard Code

In the event of a problem with the QZSS occurring upon testing, a non-standard code (NSC) is transmitted. This is done to protect users by ensuring that they do not use erroneous signals.

4. Message Format

4.1. L6 Message (Centimeter-Level Augmentation Service Message)

4.1.1. Message Structure

4.1.1.1 General

The L6 message signal structure is shown in Figure 4.1.1-1. Each message has a length of 2000 bits, consisting of a 49-bit header, a 1695-bit data section, and a 256-bit Reed-Solomon code. The transmission of each L6 message takes one second.

The header of the L6 message starts from bit 1 (MSB), followed by the data part (1695-bit), which is transmitted from bit 50. The Reed-Solomon Code is transmitted from bit 1745, after the data part. The data part for Code 1 (L6D) includes multiple RTCM STANDARD 10403.2 (applicable document (2)) compatible messages. The L6 message does not transmit the broadcast ephemeris included in each GNSS navigation message.

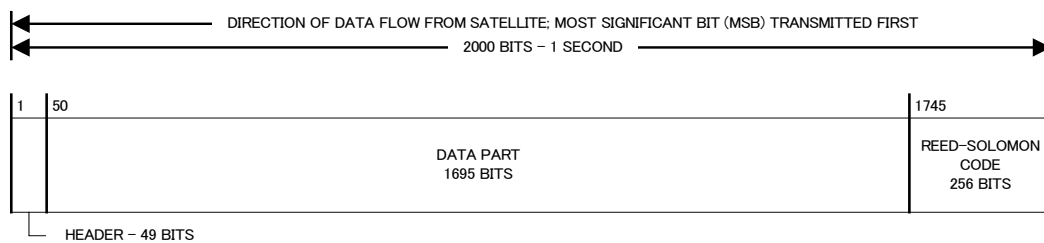

Figure 4.1.1-1 L6 Message Structure

4.1.1.2 Compositions of Augmented Satellites

There are two patterns of L6 messages with different combination of satellites to be augmented, which are assigned to each QZSS satellite as shown in Table 4.1.1-1. Which pattern the received L6D signal is can be determined by the “CLAS Transmit Pattern ID” (see section 4.1.2.1 for more information). The maximum number of satellites to be augmented is 17 for both patterns. The two patterns have up to five different combinations of satellites to be augmented, resulting in a maximum number of satellites is 22 when using the two patterns of L6 signals.

The only difference between the two patterns is the combination of satellites to be augmented. By using the logical sum of the satellites included in the two patterns, the number of satellites to be augmented can be increased up to five. If two QZSS satellites are tracked in order from the highest elevation angle, different patterns of L6 signals are obtained in most cases.

Table 4.1.1-1 Nominal Pattern of L6D Messages Transmitted by each Satellite

Satellite Name	PRN number	Transmit Pattern
QZS2	194	2
QZS4	195	1
QZS1R	196	2
QZS5	197	1
QZS3	199	1*1, 2

(*1) QZS3 normally transmits Pattern 1, but may transmit Pattern 2 as needed when other satellites are unavailable for long periods of time due to maintenance or malfunction. In this case, General NAQU will notify QZS3 to change the transmission pattern.

4.1.1.3 Timing

(1) Transmission Pattern

Section 4.1.2.2.14 shows an example of the transmission pattern. The transmission pattern of the data part in the L6 message may differ between satellites. Therefore, the user algorithm cannot assume any specific transmission pattern. When QZS is located in the southern hemisphere, there is the possibility of transmitting information other than that for Japan.

(2) Transmission Timing

During normal operation, the L6 message is transmitted at the same timing from each satellite.

(3) Update Interval

Table 4.1.1-2 shows the nominal update interval for each message. Note that the user algorithm cannot rely on any specific transmission cycle because it may be changed in the future for reasons of performance improvement.

Table 4.1.1-2 Nominal Update Interval

Message Name	Message Type ID Sub Type ID *1	Nominal Update Interval [s]
Compact SSR Mask	MT4073,1	30
Compact SSR GNSS Orbit Correction	MT4073,2	30
Compact SSR GNSS Clock Correction	MT4073,3	5
Compact SSR GNSS Satellite Code Bias	MT4073,4	30
Compact SSR GNSS Satellite Phase Bias	MT4073,5	30
Compact SSR GNSS Satellite Code and Phase Bias	MT4073,6	30
Compact SSR GNSS URA	MT4073,7	30
Compact SSR STEC Correction	MT4073,8	30
Compact SSR Gridded Correction	MT4073,9	30
Compact SSR Service Information	MT4073,10	(N/A)
Compact SSR GNSS Combined Correction	MT4073,11	5 or 30
Compact SSR Atmospheric Correction	MT4073,12	30
Null Message	(N/A)	(N/A)

(*1) Sub-type ID is compliant with Compact SSR (Message Type 4073) which is defined as a proprietary message in the applicable document (3) that is compatible with the applicable document (2) RTCM STANDARD 10403.2. Section 4.1.2.2 provides more information about the message format for each sub type.

(4) Nominal Validity Period

Each message has a nominal validity period based on each characteristic. Table 4.1.1-3 shows Nominal Validity Interval of each message. Origin of Validity Interval is exact second of QZSSST that is sent in the header part of Message that contains the information (refer to the data field “GPS Epoch Time 1s” and “GNSS Hourly Epoch Time 1s”). The quality of data is not guaranteed if outdated data is used.

Table 4.1.1-3 Nominal Validity Period

Message Name	Message Type ID Sub Type ID	Nominal Validity Period [s]
Compact SSR Mask	MT4073,1	*1
Compact SSR GNSS Orbit Correction	MT4073,2	60
Compact SSR GNSS Clock Correction	MT4073,3	10
Compact SSR GNSS Satellite Code Bias	MT4073,4	60
Compact SSR GNSS Satellite Phase Bias	MT4073,5	60
Compact SSR GNSS Satellite Code and Phase Bias	MT4073,6	60
Compact SSR GNSS URA	MT4073,7	60
Compact SSR STEC Correction	MT4073,8	60
Compact SSR Gridded Correction	MT4073,9	60
Compact SSR Service Information	MT4073,10	(N/A)
Compact SSR GNSS Combined Correction	MT4073,11	10 or 60
Compact SSR Atmospheric Correction	MT4073,12	60
Null Message	(N/A)	(N/A)

*1 Validity interval of Compact SSR Mask is described in 4.1.2.2.2 (6).

4.1.2. Message contents

4.1.2.1 Header Part

The header of the L6 message is shown in Figure 4.1.2-1. The header part has a length of 49-bit consisting of a 32-bit preamble, an 8-bit PRN, an 8-bit L6 message type ID and a 1-bit alert flag. Table 4.1.2-1 defines the header parameters.

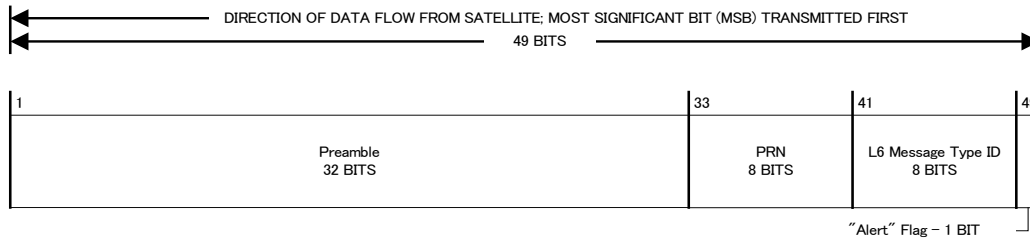

Figure 4.1.2-1 Header of L6 message

Table 4.1.2-1 Definitions of header parameters

DF Name	DF Range	BIT	LSB	DF Unit	Note
Preamble	-	32	-	-	
PRN	-	8	-	-	
L6 Message Type ID	-	8	-	-	
"Alert" Flag	-	1	-	-	

(1) Preamble

At the beginning of each message is a 32-bit preamble. The value of the preamble is "0001101011001111111110000011101"_(B).

(2) PRN

Each message has an 8-bit PRN number immediately after the preamble. The PRN number is the PRN number of the satellite transmitting that message. For PRN No. = 193 - 211, then the satellite is QZSS.

(3) L6 Message Type ID (CLAS)

Each message has an 8-bit L6 message type ID immediately following the PRN. Table 4.1.2-2 lists the definitions of the L6 message type ID parameters.

The first 3-bit are the Vendor ID for CLAS. The following 2-bit indicate the message generation facility and the CLAS transmit pattern. The following 2-bit indicate the CLAS transmit pattern. The combination of “Message Generation Facility and CLAS Transmit Pattern ID” and “CLAS Transmit Pattern ID” can be used to determine Facility. The last 1-bit is the indicator for the subframe header. If the value of this indicator is “1”, the message is the start of a subframe. In the user algorithm, the Compact SSR messages with the same Vendor ID and “Message Generation Facility and CLAS Transmit Pattern ID” encoded in the header of L6 message every second should be used.

If the above condition is not met, Compact SSR messages with a previous set of the Vendor ID and the “Message Generation Facility and CLAS Transmit Pattern ID” should be used.

Table 4.1.2-2 L6 message type ID (CLAS)

Bit Field	Data Name	Note
7-5	Vendor ID	“101” _(B) for CLAS
4-3	Message Generation Facility and CLAS Transmit Pattern ID	“00” _(B) : Facility1 Pattern1 or Facility3 Pattern2 “01” _(B) : Facility1 Pattern2 or Facility3 Pattern1 “10” _(B) : Facility2 Pattern1 or Facility4 Pattern2 “11” _(B) : Facility2 Pattern2 or Facility4 Pattern1
2-1	CLAS Transmit Pattern ID	“00” _(B) : Pattern 1 “01” _(B) : Pattern 2 “10” _(B) : Reserved “11” _(B) : Reserved
0	Subframe indicator	“1” _(B) : first data part of a subframe “0” _(B) : others

(*1) See section 4.1.1.2 for more information on CLAS Transmit Pattern.

(4) Alert Flag

Each message has a 1-bit alert flag immediately following the L6 Message Type ID. The Alert Flag indicates the health status of CLAS. When the Alert flag is “1”_(B), the service is not available.

4.1.2.2 Data Part

4.1.2.2.1 General

The nominal sequence of the CLAS message consists of 30 successive data parts of the L6 Message. Five successive data parts of the L6 message constitute a subframe. Six successive subframes of the L6 message constitute a frame. Sub Type ID 1 - 12 is transmitted in a given order. When the messages of the same sub type are transmitted within one subframe for Sub Type ID 1 - 7, users must use the latest message in the subframe. Figure 4.1.2-2 shows the structure of the L6 message, frame, and subframe.

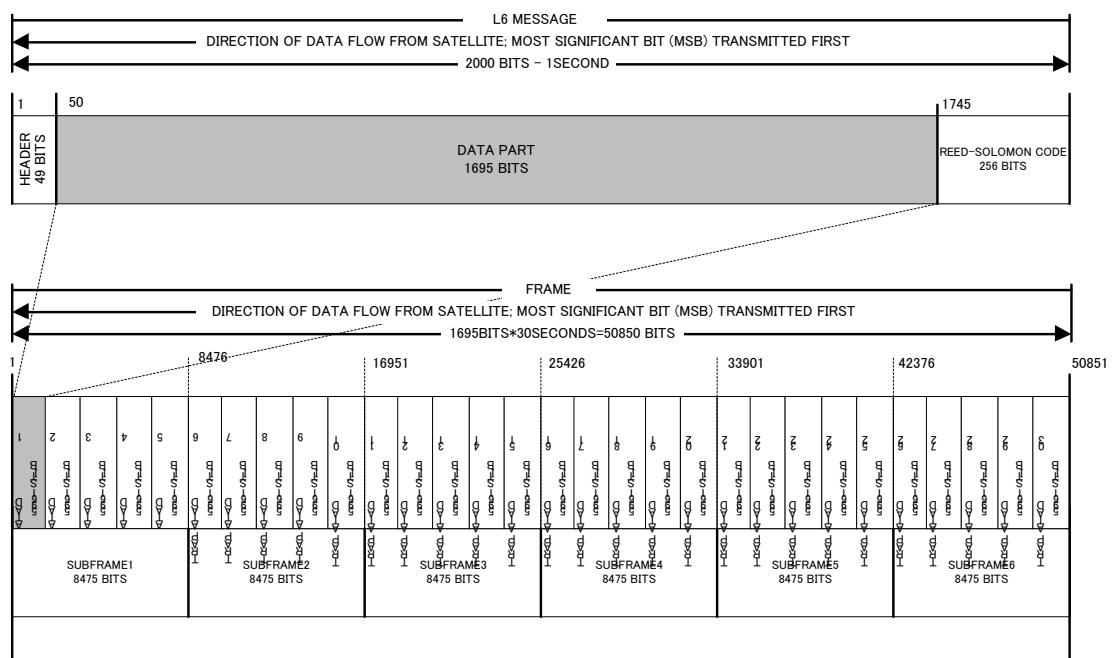

Figure 4.1.2-2 Structure of L6 message, frame, and subframe

The data part of the L6 message includes any sub type of multiple messages of MT 4073 “Compact SSR,” as defined in the applicable document (3). The data in each message is given in state space representation (SSR) form, as standardized in the applicable document (2) RTCM STANDARD 10403.2. The correction in SSR form can be applied to precise point positioning - real-time kinematic (PPP-RTK). In the user algorithm, the SSR correction can be converted into a range correction in the observation space representation (OSR) and can be applied to the positioning calculation right after message acquisition if its user position is acquired by standalone positioning. The integer ambiguity of the carrier phase can be resolved by the single difference between satellites or the double difference between satellites and a virtual reference station.

Table 4.1.2-3 RTCM STANDARD 10403.2 Message Type 4073 Definition of Sub Type

Sub Type	Sub Type Name	No. of Bit*	Notes
1**	Compact SSR Mask	$49+(61+N_{\text{cell}})\times N_{\text{sys}}$	4.1.2.2.2
2	Compact SSR GNSS Orbit Correction	$37+(51 \text{ or } 49) \times N_{\text{sat}}$	4.1.2.2.3
3	Compact SSR GNSS Clock Correction	$37+15\times N_{\text{sat}}$	4.1.2.2.4
4	Compact SSR GNSS Satellite Code Bias	$37+11\times N_{\text{sig}}\times N_{\text{sat}}$	4.1.2.2.5
5	Compact SSR GNSS Satellite Phase Bias	$37+17\times N_{\text{sig}}\times N_{\text{sat}}$	4.1.2.2.6
6***	Compact SSR GNSS Satellite Code and Phase Bias	$45+ N_{\text{sat}} + (11 \text{ or } 17 \text{ or } 28)\times N_{\text{sig}}\times M_{\text{sat}}$	4.1.2.2.7
7	Compact SSR GNSS URA	$37+6\times N_{\text{sat}}$	4.1.2.2.8
8	Compact SSR STEC Correction	$44+N_{\text{sat}}+(20 \text{ or } 44 \text{ or } 54 \text{ or } 70)\times M_{\text{sat}}$	4.1.2.2.9
9	Compact SSR Gridded Correction	$57+N_{\text{sat}}+(17+(7 \text{ or } 16)\times M_{\text{sat}})\times N_{\text{grid}}$	4.1.2.2.10
10	Compact SSR Service Information	TBD	4.1.2.2.11
11	Compact SSR GNSS Combined Correction	$40+5+N_{\text{sat}}+(15 \text{ or } (+49 \text{ or } +51))\times M_{\text{sat}}$	4.1.2.2.12
12	Compact SSR Atmospheric Correction	$52+(22\text{or}36\text{or}43)+(6\text{or}8)\times N_{\text{grid}} + N_{\text{sat}} + (8+(14\text{or}38\text{or}48\text{or}64))+2+(4\text{or}5\text{or}7)\times N_{\text{grid}}\times M_{\text{sat}}$	4.1.2.2.13

* N_{cell} = No. of Cell Mask of each GNSS, N_{sat} = No. of satellite, N_{sig} = No. of signal, N_{sys} = No. of GNSS, M_{sat} = No. of satellite in local network, N_{grid} = No. of grid in local network

** The size of N_{cell} depends on each GNSS

*** In the case of “Network Bias Correction” equals to “0”_(B), “No. of Bit” equals “ $40+28\times N_{\text{sig}}\times N_{\text{sat}}$ ”.

**** The size of N_{sig} depends on the number of signals which are set to 1 in the filed “Compact SSR Signal mask” of Sub Type 1.

4.1.2.2.2 Sub Type 1 – Compact SSR Mask Message

The sub type 1 message structure is shown in Figure 4.1.2-3. The message header and GNSS specific part are defined in Table 4.1.2-4 and Table 4.1.2-5, respectively.

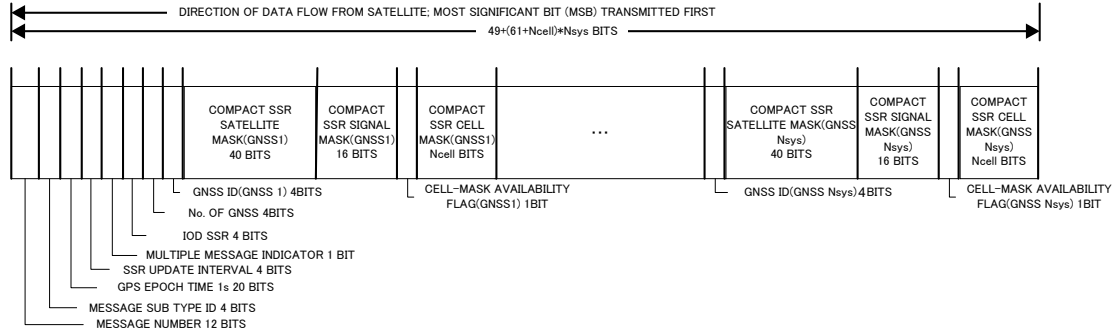

Figure 4.1.2-3 Compact SSR Mask Message structure

Table 4.1.2-4 Contents of message header, Compact SSR Mask Message

DF Name	DF Range	BIT	LSB	DF Unit	Note
Message Number	0-4095	12	-	-	4073
Message Sub Type ID	0-15	4	-	-	1
GPS Epoch Time 1s	0-604799	20	1	s	
SSR Update Interval	0-15	4	1	-	
Multiple Message Indicator	0-1	1	1	-	
IOD SSR	0-15	4	1	-	
No. of GNSS	0-15	4	1	-	

Table 4.1.2-5 Contents of GNSS-specific part of Compact SSR Mask Message

DF Name	DF Range	BIT	LSB	DF Unit	Note
GNSS ID 1	0-15	4	-	-	
Compact SSR Satellite mask 1	-	40	-	-	
Compact SSR Signal mask 1	-	16	-	-	
Cell-mask Availability Flag	0-1	1			
Compact SSR Cell mask 1	-	N_{cell}	-	-	
					}
GNSS ID N_{sys}	0-15	4	-	-	
Compact SSR Satellite mask N_{sys}	-	40	-	-	
Compact SSR Signal mask N_{sys}	-	16	-	-	
Cell-mask Availability Flag	0-1	1			
Compact SSR Cell mask N_{sys}	-	N_{cell}	-	-	

(1) Message Number

The message number is defined in "RTCM STANDARD 10403.2" (applicable document (2)). Until the standardization of compact SSR has been completed, 4073 is used as the proprietary message.

(2) Message Sub-Type ID

The message sub-type ID is defined in the compact SSR specification (applicable document (3)).

(3) GPS Epoch Time 1s

Seconds since the beginning of the GPS week. The data is defined in QZSST.

(4) SSR Update Interval

The SSR update intervals for all the SSR parameters start at time 00:00:00 of the QZSST time frame. The supported SSR update intervals are listed in Table 4.1.2-6.

Table 4.1.2-6 SSR update interval

SSR Update Interval	Update Interval
0	1 s
1	2 s
2	5 s
3	10 s
4	15 s
5	30 s
6	60 s
7	120 s
8	240 s
9	300 s
10	600 s
11	900 s
12	1800 s
13	3600 s
14	7200 s
15	10800 s

(5) Multiple Message Indicator

Indicator for transmitting message with the same message number, message sub-type ID, Compact Network ID, and epoch time. "0": last message of a sequence, "1": multiple message transmitted.

(6) IOD SSR

A change of issue of data SSR is used to indicate a change in the SSR generating configuration. The IOD SSR is combined with the CLAS Transmit Pattern indicator as shown in Table 4.1.2-7. The IOD SSR content is counted up from 0₍₁₀₎. When the compact SSR satellite mask, compact SSR signal mask, or compact SSR cell mask have been changed, the IOD SSR is counted up.

Table 4.1.2-7 IOD SSR

Bit Field	Data Name	Note
3	CLAS Transmit Pattern indicator	“0” _(B) : Pattern 1 “1” _(B) : Pattern 2
2-0	IOD SSR Content	Counted up from “000” _(B) to “111” _(B)

(7) No. of GNSS

Number of augmented GNSS.

(8) GNSS ID

Indicator for specifying the GNSS. Table 4.1.2-8 lists the reciprocal relationship between the GNSS ID and GNSS.

Table 4.1.2-8 GNSS ID

GNSS ID	GNSS
0	GPS
1	GLONASS
2	Galileo
3	BeiDou
4	QZSS
5	SBAS
6-9	Reserved

(9) Compact SSR Satellite mask

The sequence of bits, which specifies those GNSS satellites for which data is augmented in this message. The most significant bit (MSB), or the first encoded bit corresponds to that GNSS satellite for which ID = 1, the second bit corresponds to a GNSS satellite for which ID = 2, etc. The least significant bit (LSB), or the last-encoded bit corresponds to a GNSS satellite with ID = 40. For QZSS, a satellite with ID = 1-10 is PRN193-202. Table 4.1.2-9 lists the reciprocal relationships between the compact SSR satellite mask and GNSS.

Table 4.1.2-9 Compact SSR satellite mask

Compact SSR Satellite Mask	0	1	2	3	4	5	6	7	8	9	10	11	12	13	14
GPS	1	2	3	4	5	6	7	8	9	10	11	12	13	14	15
GLONASS	1	2	3	4	5	6	7	8	9	10	11	12	13	14	15
Galileo	1	2	3	4	5	6	7	8	9	10	11	12	13	14	15
BeiDou	1	2	3	4	5	6	7	8	9	10	11	12	13	14	15
QZSS	193	194	195	196	197	198	199	200	201	202	Reserved				

Compact SSR Satellite Mask	15	16	17	18	19	20	21	22	23	24	25	26	27	28	29
GPS	16	17	18	19	20	21	22	23	24	25	26	27	28	29	30
GLONASS	16	17	18	19	20	21	22	23	24	Reserved					
Galileo	16	17	18	19	20	21	22	23	24	25	26	27	28	29	30
BeiDou	16	17	18	19	20	21	22	23	24	25	26	27	28	29	30
QZSS	Reserved														

Compact SSR Satellite Mask	30	31	32	33	34	35	36	37	38	39
GPS	31	32	33	34	35	36	37	38	39	40
GLONASS	Reserved									
Galileo	31	32	33	34	35	36	37	Reserved		
BeiDou	31	32	33	34	35	36	37	38	39	40
QZSS	Reserved									

(10) Compact SSR Signal mask

The sequence of bits which defines the selected signals for correction messages defined for each GNSS, as listed in Table 4.1.2-10.

Table 4.1.2-10 Compact SSR signal mask

Compact SSR Signal mask	GPS	GLONASS	Galileo	BeiDou	QZSS	SBAS
0	L1 C/A	G1 C/A	E1 B1/NAV OS/CS/SoL	B1 I	L1 C/A	L1 C/A
1	L1 P	G1 P	E1 C no data	B1 Q	L1 L1C(D)	L5 I
2	L1 Z-tracking	G2 C/A	E1 B+C	B1 I+Q	L1 L1C(P)	L5 Q
3	L1 L1C(D)	G2 P	E5a I F/NAV OS	B3 I	L1 L1C(D+P)	L5 I+Q
4	L1 L1C(P)	G1a(D)	E5a Q no data	B3 Q	L2 L2C(M)	
5	L1 L1C(D+P)	G1a(P)	E5a I+Q	B3 I+Q	L2 L2C(L)	
6	L2 L2C(M)	G1a(D+P)	E5b I1/NAV OS/CS/SoL	B2 I	L2 L2C(M+L)	
7	L2 L2C(L)	G2a(D)	E5b Q no data	B2 Q	L5 I	
8	L2 L2C(M+L)	G2a(P)	E5b I+Q	B2 I+Q	L5 Q	
9	L2 P	G2a(D+P)	E5 I		L5 I+Q	
10	L2 Z-tracking	G3 I	E5 Q			
11	L5 I	G3 Q	E5 I+Q			
12	L5 Q	G3 I+Q	Service specific 1			
13	L5 I+Q		Service specific 2			
14			Service specific 3			
15						

(11) Cell-mask Availability Flag

If the flag set to “1”_(B), the cell-mask is included.

(12) Compact SSR Cell Mask

The sequence of bits, which specifies those signals for which data is available in this message for each satellite. Note that the cell mask is not included if the cell-mask availability flag is set to zero. In this case, all of the signals included in the signal mask are selected for all the selected satellites.

Document subject to the disclaimer of liability

4.1.2.2.3 Sub Type 2 – Compact SSR GNSS Orbit Correction Message

The sub type 2 message structure is shown in Figure 4.1.2-4. The message header and satellite-specific part are defined in Table 4.1.2-11 and Table 4.1.2-12, respectively.

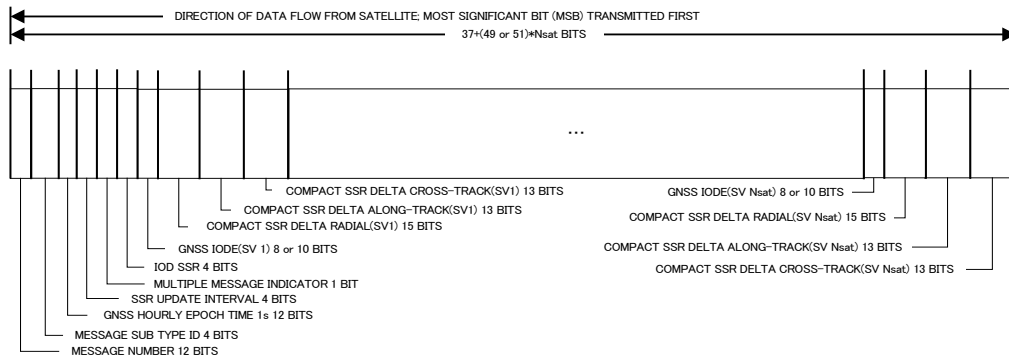

Figure 4.1.2-4 Compact SSR GNSS Orbit Correction Message structure

Table 4.1.2-11 Contents of message header, compact SSR GNSS Orbit Correction Message

DF Name	DF Range	BIT	LSB	DF Unit	Note
Message Number	0-4095	12	-	-	4073
Message Sub Type ID	0-15	4	-	-	2
GNSS Hourly Epoch Time 1s	0-3599	12	1	s	3600-4095 indicates data not available
SSR Update Interval	0-15	4	1	-	
Multiple Message Indicator	0-1	1	1	-	
IOD SSR	0-15	4	1	-	

Table 4.1.2-12 Contents of satellite-specific part of compact SSR GNSS Orbit Correction Message

DF Name	DF Range	BIT	LSB	DF Unit	Note
GNSS IODE(SV 1)	0-255 or 0-1023	8 or 10	1	-	
Compact SSR Delta Radial(SV 1)	±26.2128	15	0.0016	m	-26.2144 indicates data not available
Compact SSR Delta Along-Track(SV 1)	±26.208	13	0.0064	m	-26.2144 indicates data not available
Compact SSR Delta Cross-Track(SV 1)	±26.208	13	0.0064	m	-26.2144 indicates data not available
λ					
GNSS IODE(SV Nsat)	0-255 or 0-1023	8 or 10	1	-	
Compact SSR Delta Radial (SV Nsat)	±26.2128	15	0.0016	m	-26.2144 indicates data not available
Compact SSR Delta Along-Track (SV Nsat)	±26.208	13	0.0064	m	-26.2144 indicates data not available
Compact SSR Delta Cross-Track (SV Nsat)	±26.208	13	0.0064	m	-26.2144 indicates data not available

(1) GNSS Hourly Epoch Time 1 s

Hours, minutes, and seconds part of GPS epoch time.

(2) GNSS IODE

IODE value of broadcast ephemeris used for calculation of range correction. Here, 10-bit are assigned for Galileo, and 8-bit are assigned for other GNSS.

(3) Compact SSR Delta Radial, Along-Track and Cross-Track

Radial, along-track and cross-track orbit correction for broadcast ephemeris. In the user algorithm, the appropriate broadcast ephemeris provided by the navigation message defined in Table 4.1.2-13 should be used.

Table 4.1.2-13 Augmented Navigation Message¹

GNSS	Navigation Message
GPS	LNAV
GLONASS (FDMA)	GLONASS-M
GLONASS (CDMA)	GLONASS-K
Galileo	I/NAV
BeiDou	D1
QZSS	LNAV

(4) IOD SSR

A change of issue of data SSR is used to indicate a change in the information included in the compact SSR mask message.

¹ In which of this definition, supported GNSS in CLAS is defined in Section 6.1 of the applicable document (1).

4.1.2.2.4 Sub Type 3 – Compact SSR GNSS Clock Correction Message

The sub-type 3 message structure is shown in Figure 4.1.2-5. The message header and satellite-specific part are defined in Table 4.1.2-14 and Table 4.1.2-15, respectively.

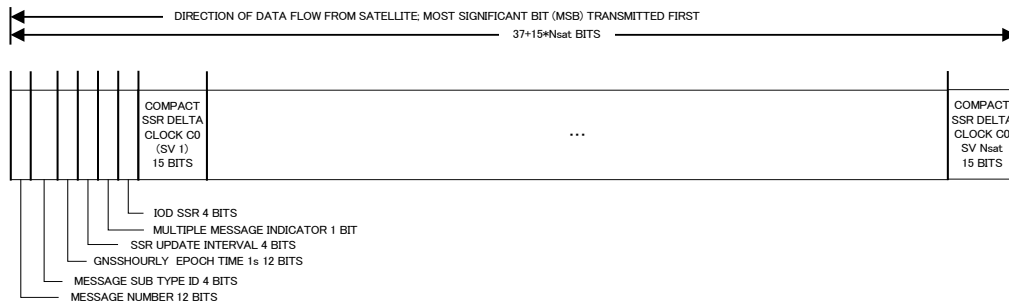

Figure 4.1.2-5 Compact SSR GNSS Clock Correction Message structure

Table 4.1.2-14 Contents of message header, compact SSR GNSS Clock Correction Message

DF Name	DF Range	BIT	LSB	DF Unit	Note
Message Number	0-4095	12	-	-	4073
Message Sub Type ID	0-15	4	-	-	3
GNSS Hourly Epoch Time 1s	0-3599	12	1	s	3600-4095 indicates data not available
SSR Update Interval	0-15	4	1	-	
Multiple Message Indicator	-	1	-	-	
IOD SSR	0-15	4	1	-	

Table 4.1.2-15 Contents of satellite-specific part of the compact SSR GNSS Clock Correction Message

DF Name	DF Range	BIT	LSB	DF Unit	Note
Compact SSR Delta Clock C0 (SV1)	±26.2128	15	0.0016	m	-26.2144 indicates data not available
}					
Compact SSR Delta Clock C0 (SV Nsat)	±26.2128	15	0.0016	m	-26.2144 indicates data not available

(1) Compact SSR Delta Clock

The bias term (C0) of clock correction for broadcast ephemeris. In the user algorithm, the appropriate broadcast ephemeris provided by the navigation message defined in Table 4.1.2-13 should be used.

4.1.2.2.5 Sub Type 4 – Compact SSR GNSS Satellite Code Bias Message

The sub type 4 message structure is shown in Figure 4.1.2-6. The message header and satellite-specific part are defined in Table 4.1.2-16 and Table 4.1.2-17, respectively.

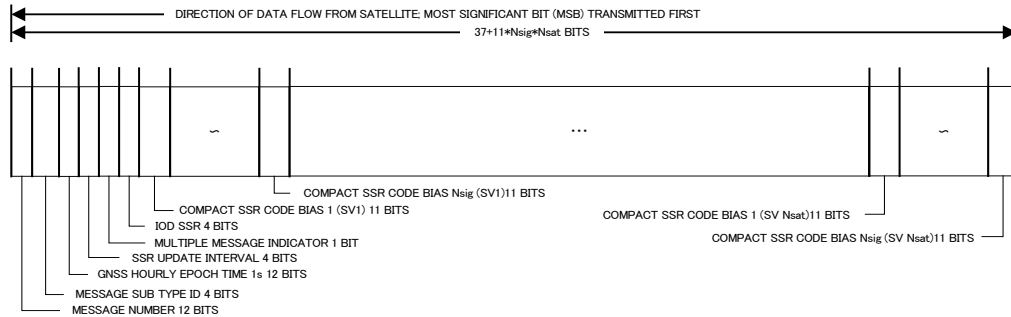

Figure 4.1.2-6 Compact SSR GNSS satellite code bias message structure

Table 4.1.2-16 Contents of message header, compact SSR GNSS satellite code bias message

DF Name	DF Range	BIT	LSB	DF Unit	Note
Message Number	0-4095	12	-	-	4073
Message Sub Type ID	0-15	4	-	-	4
GNSS Hourly Epoch Time 1s	0-3599	12	1	s	3600-4095 indicates data not available
SSR Update Interval	0-15	4	1	-	
Multiple Message Indicator	-	1	-	-	
IOD SSR	0-15	4	1	-	

Table 4.1.2-17 Contents of satellite-specific part of compact SSR GNSS satellite code bias message

DF Name	DF Range	BIT	LSB	DF Unit	Note
Compact SSR Code Bias 1 (SV 1)	±20.46	11	0.02	m	-20.48 indicates data not available
}					
Compact SSR Code Bias $N_{code}(SV 1)$	±20.46	11	0.02	m	-20.48 indicates data not available
}					
Compact SSR Code Bias 1 (SV N_{sat})	±20.46	11	0.02	m	-20.48 indicates data not available
}					
Compact SSR Code Bias $N_{code}(SV N_{sat})$	±20.46	11	0.02	m	-20.48 indicates data not available

(1) Compact SSR Code Bias

This code bias is an absolute value. The code biases must be added to the pseudo range measurements of the corresponding code signal to get corrected pseudo ranges.

The compact SSR code bias for the satellite of each GNSS is transmitted in the order indicated in Sub Type 1: Compact SSR Mask. Only the signal indicated by the compact SSR cell mask is transmitted in this message.

4.1.2.2.6 Sub Type 5 – Compact SSR GNSS Satellite Phase Bias Message

The sub type 5 message structure is shown in Figure 4.1.2-7. The message header and satellite-specific part are defined in Table 4.1.2-18 and Table 4.1.2-19 respectively.

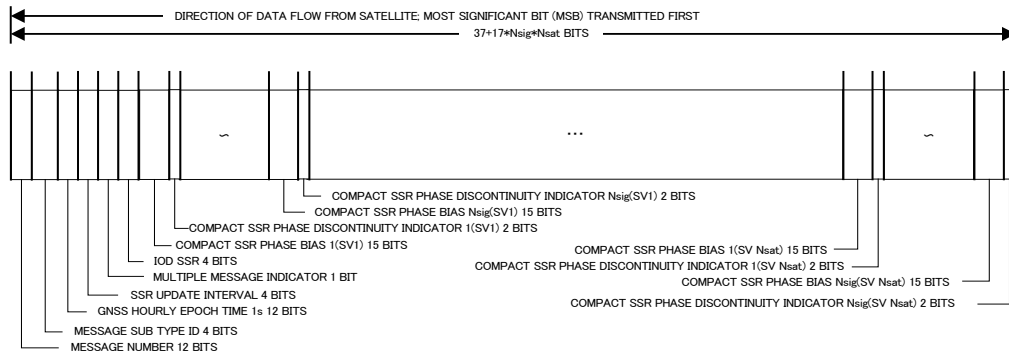

Figure 4.1.2-7 Compact SSR GNSS Satellite Phase Bias Message structure

Table 4.1.2-18 Contents of message header, Compact SSR Satellite Phase Bias Message

DF Name	DF Range	BIT	LSB	DF Unit	Note
Message Number	0-4095	12	-	-	4073
Message Sub Type ID	0-15	4	-	-	5
GNSS Hourly Epoch Time 1s	0-3599	12	1	s	3600-4095 indicates data not available
SSR Update Interval	0-15	4	1	-	
Multiple Message Indicator	-	1	-	-	
IOD SSR	0-15	4	1	-	

Table 4.1.2-19 Contents of satellite-specific part of Compact SSR GNSS Satellite Phase Bias Message

DF Name	DF Range	BIT	LSB	DF Unit	Note
Compact SSR Phase Bias1 (SV1)	±16.383	15	0.001	m	-16.384 indicates data not available
Compact SSR Phase Discontinuity Indicator1 (SV 1)	0-3	2	1	-	
}					
Compact SSR Phase Bias N _{phase} (SV 1)	±16.383	15	0.001	m	-16.384 indicates data not available
Compact SSR Phase Discontinuity IndicatorN _{phase} (SV 1)	0-3	2	1	-	
}					
Compact SSR Phase Bias 1 (SV N _{sat})	±16.383	15	0.001	m	-16.384 indicates data not available
Compact SSR Phase Discontinuity Indicator1 (SV N _{sat})	0-3	2	1	-	
}					
Compact SSR Phase Bias N _{phase} (SV N _{sat})	±16.383	15	0.001	m	-16.384 indicates data not available
Compact SSR Phase Discontinuity Indicator N _{phase} (SV N _{sat})	0-3	2	1	-	

(1) Compact SSR Phase Bias

SSR Phase bias for specified signal. The compact SSR phase bias for the satellite of each GNSS is transmitted in the order indicated by sub type 1: compact SSR mask. Only the signal indicated by compact SSR cell mask is transmitted with this message.

(2) Phase discontinuity indicator

The phase discontinuity indicator is counted up when the phase bias is discontinuous.

4.1.2.2.7 Sub Type 6 – Compact SSR GNSS Satellite Code and Phase Bias

The sub type 6 message structure is shown in Figure 4.1.2-8. The message header and satellite-specific part are defined in Table 4.1.2-20 and Table 4.1.2-21, respectively.

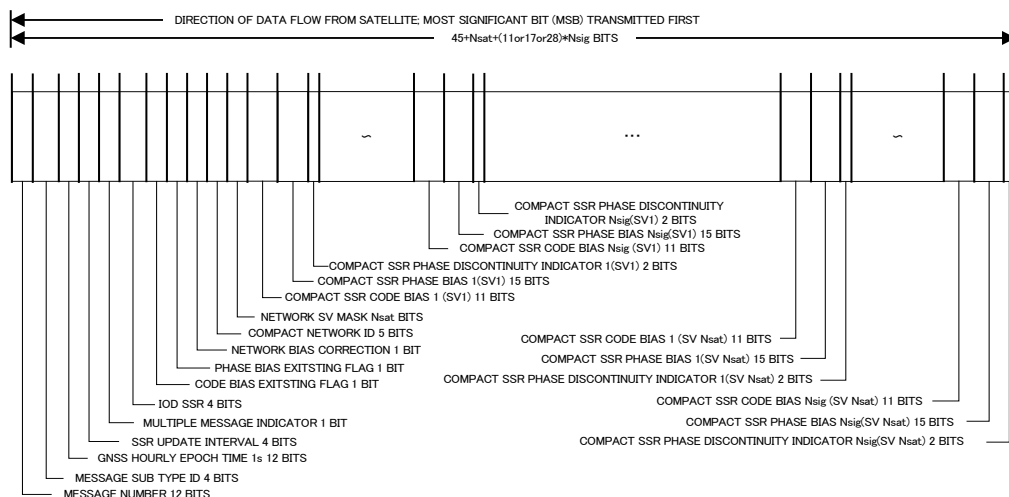

Figure 4.1.2-8 Compact SSR GNSS Satellite Code and Phase Bias Message structure

Table 4.1.2-20 Contents of message header, Compact SSR GNSS Satellite Code and Phase Bias Message

DF Name	DF Range	BIT	LSB	DF Unit	Note
Message Number	0-4095	12	-	-	4073
Message Sub Type ID	0-15	4	-	-	6
GNSS Hourly Epoch Time 1s	0-3599	12	1	s	3600-4095 indicates data not available
SSR Update Interval	0-15	4	1	-	
Multiple Message Indicator	-	1	-	-	
IOD SSR	0-15	4	1	-	
Code Bias Existing Flag	-	1	-	-	
Phase Bias Existing Flag	-	1	-	-	
Network Bias Correction	-	1	-	-	
Compact Network ID	0-31	5	1	-	Included only if "Network Bias Correction" equals to "1" 0 - undefined
Network SV Mask	-	N_{sat}	1	-	Included only if "Network Bias Correction" equals to "1"

Table 4.1.2-21 Contents of satellite-specific part of Compact SSR GNSS Satellite Code and Phase Bias Message

DF Name	DF Range	BIT	LSB	DF Unit	Note
Compact SSR Code Bias 1 (SV 1)	± 20.46	11	0.02	m	-20.48 indicates data not available Included only if "Code Bias Existing Flag" equals to "1"
Compact SSR Phase Bias1 (SV1)	± 16.383	15	0.001	m	-16.384 indicates data not available Included only if "Phase Bias Existing Flag" equals to "1"
Compact SSR Phase Discontinuity Indicator1 (SV 1)	0-3	2	1	-	Included only if "Phase Bias Existing Flag" equals to "1"
}					
Compact SSR Code Bias N_{code} (SV 1)	± 20.46	11	0.02	m	-20.48 indicates data not available Included only if "Code Bias Existing Flag" equals to "1"
Compact SSR Phase Bias N_{phase} (SV 1)	± 16.383	15	0.001	m	-16.384 indicates data not available Included only if "Phase Bias Existing Flag" equals to "1"
Compact SSR Phase Discontinuity Indicator N_{phase} (SV 1)	0-3	2	1	-	Included only if "Phase Bias Existing Flag" equals to "1"
Compact SSR Code Bias 1 (SV 2)	± 20.46	11	0.02	m	-20.48 indicates data not available Included only if "Code Bias Existing Flag" equals to "1"
Compact SSR Phase Bias 1 (SV 2)	± 16.383	15	0.001	m	-16.384 indicates data not available Included only if "Phase Bias Existing Flag" equals to "1"
Compact SSR Phase Discontinuity Indicator1 (SV 2)	0-3	2	1	-	Included only if "Phase Bias Existing Flag" equals to "1"
}					
Compact SSR Code Bias N_{code} (SV N_{sat})	± 20.46	11	0.02	m	-20.48 indicates data not available Included only if "Code Bias Existing Flag" equals to "1"
Compact SSR Phase Bias N_{phase} (SV N_{sat})	± 16.383	15	0.001	m	-16.384 indicates data not available Included only if "Phase Bias Existing Flag" equals to "1"
Compact SSR Phase Discontinuity Indicator N_{phase} (SV N_{sat})	0-3	2	1	-	Included only if "Phase Bias Existing Flag" equals to "1"

(1) Code Bias Existing Flag

If the flag set to "1"_(B), Code Bias is included.

(2) Phase Bias Existing Flag

If the flag set to "1"_(B), Phase Bias is included.

(3) Network Bias Correction

If the flag set to "1"_(B), correction for Phase or Code Bias in local network

4.1.2.2.8 Sub Type 7 – Compact SSR GNSS URA Message

The Sub Type 7 Message structure is shown in Figure 4.1.2-9. The message header and satellite-specific part are defined in Table 4.1.2-22 and Table 4.1.2-23, respectively.

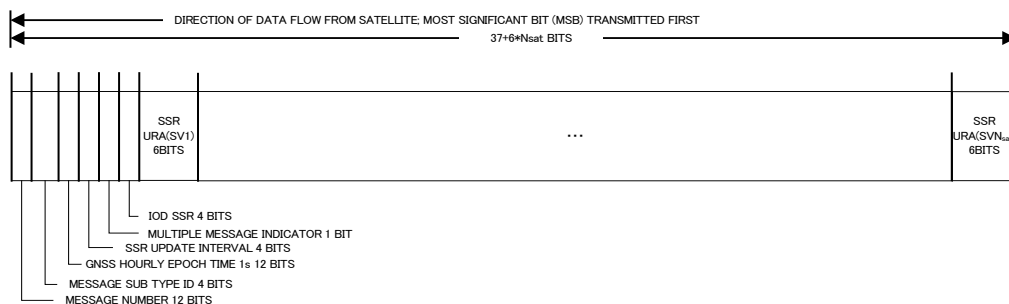

Figure 4.1.2-9 Compact SSR GNSS URA Message structure

Table 4.1.2-22 Contents of message header, compact SSR URA Message

DF Name	DF Range	BIT	LSB	DF Unit	Note
Message Number	0-4095	12	-	-	4073
Message Sub Type ID	0-15	4	-	-	7
GNSS Hourly Epoch Time 1s	0-3599	12	1	s	3600-4095 indicates data not available
SSR Update Interval	0-15	4	1	-	
Multiple Message Indicator	-	1	-	-	
IOD SSR	0-15	4	1	-	

Table 4.1.2-23 Contents of satellite-specific part of compact SSR GNSS URA message

DF Name	DF Range	BIT	LSB	DF Unit	Note
SSR URA (SV1)	bits 5-3 : 0-7 bits 2-0 : 0-7	6	-	-	
}					
SSR URA (SV Nsat)	bits 5-3 : 0-7 bits 2-0 : 0-7	6	-	-	

(1) SSR URA

SSR users range accuracy (URA) (1 sigma) for range correction computed from a complete signal in space specific SSR set as disseminated by the compact SSR messages. The URA is represented by a combination of URA_CLASS and URA_VALUE. The 3 MSBs define the URA_CLASS within a range of 0-7 while the 3 LSBs define the URA_VALUE within a range of 0-7. The URA is computed as described in 5.4.2.

4.1.2.2.9 Sub Type 8 – Compact SSR STEC Correction Message

The sub type 8 message structure is shown Figure 4.1.2-10. The message header and satellite-specific part are defined in Table 4.1.2-24 and Table 4.1.2-25, respectively.

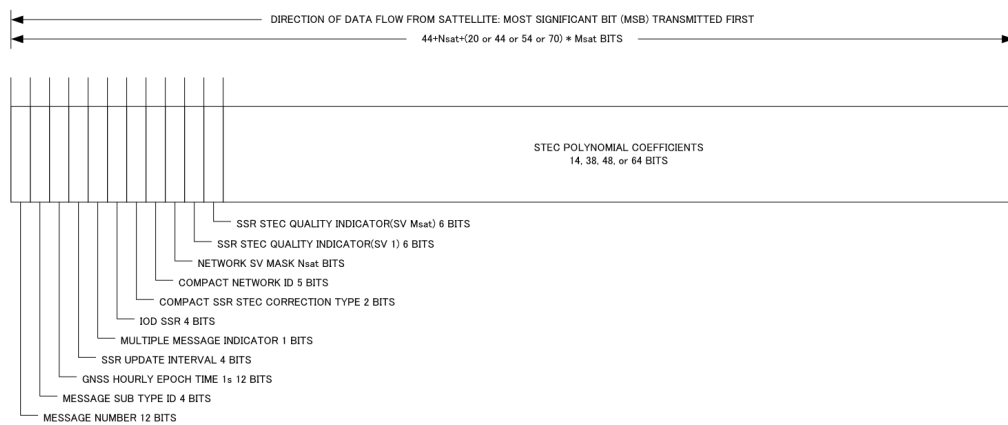

Figure 4.1.2-10 Compact SSR STEC Correction Message structure

Table 4.1.2-24 Contents of message header, Compact SSR STEC Correction Message

DF Name	DF Range	BIT	LSB	DF Unit	Note
Message Number	0-4095	12	-	-	4073
Message Sub Type ID	0-15	4	-	-	8
GNSS Hourly Epoch Time 1_s	0-3599	12	1	s	3600-4095 indicates data not available
SSR Update Interval	0-15	4	1	-	
Multiple Message Indicator	-	1	-	-	
IOD SSR	0-15	4	1	-	
Compact SSR STEC Correction Type	0-3	2	1		
Compact Network ID	0-31	5	1	-	0 - undefined
Network SV mask	-	N_{sat}	1	-	

Table 4.1.2-25 Contents of satellite-specific part of Compact SSR STEC Correction Message

(i) STEC correction type = 0

DF Name	DF Range	BIT	LSB	DF Unit	Note
SSR STEC Quality Indicator(SV 1)	bits 5-3 : 0-7 bits 2-0 : 0-7	6	-	-	
STEC Polynomial Coefficients C_{00} (SV 1)	± 409.55	14	0.05	TECU	-409.6 indicates data not available
}					
SSR STEC Quality Indicator(SV M_{sat})	bits 5-3 : 0-7 bits 2-0 : 0-7	6	-	-	
STEC Polynomial Coefficients C_{00} (SV M_{sat})	± 409.55	14	0.05	TECU	-409.6 indicates data not available

(ii) STEC correction type = 1

DF Name	DF Range	BIT	LSB	DF Unit	Note
SSR STEC Quality Indicator(SV 1)	bits 5-3 : 0-7 bits 2-0 : 0-7	6	-	-	
STEC Polynomial Coefficients C_{00} (SV 1)	± 409.55	14	0.05	TECU	-409.6 indicates data not available
STEC Polynomial Coefficients C_{01} (SV 1)	± 40.94	12	0.02	TECU /deg	-40.96 indicates data not available
STEC Polynomial Coefficients C_{10} (SV 1)	± 40.94	12	0.02	TECU /deg	-40.96 indicates data not available
}					
SSR STEC Quality Indicator(SV M_{sat})	bits 5-3 : 0-7 bits 2-0 : 0-7	6	-	-	
STEC Polynomial Coefficients C_{00} (SV M_{sat})	± 409.55	14	0.05	TECU	-409.6 indicates data not available
STEC Polynomial Coefficients C_{01} (SV M_{sat})	± 40.94	12	0.02	TECU /deg	-40.96 indicates data not available
STEC Polynomial Coefficients C_{10} (SV M_{sat})	± 40.94	12	0.02	TECU /deg	-40.96 indicates data not available

(iii) STEC correction type = 2

DF Name	DF Range	BIT	LSB	DF Unit	Note
SSR STEC Quality Indicator(SV 1)	bits 5-3 : 0-7 bits 2-0 : 0-7	6	-	-	
STEC Polynomial Coefficients C_{00} (SV 1)	± 409.55	14	0.05	TECU	-409.6 indicates data not available
STEC Polynomial Coefficients C_{01} (SV 1)	± 40.94	12	0.02	TECU /deg	-40.96 indicates data not available
STEC Polynomial Coefficients C_{10} (SV 1)	± 40.94	12	0.02	TECU /deg	-40.96 indicates data not available
STEC Polynomial Coefficients C_{11} (SV 1)	± 10.22	10	0.02	TECU /deg ²	-10.24 indicates data not available
}					
SSR STEC Quality Indicator(SV M_{sat})	bits 5-3 : 0-7 bits 2-0 : 0-7	6	-	-	
STEC Polynomial Coefficients C_{00} (SV M_{sat})	± 409.55	14	0.05	TECU	-409.6 indicates data not available
STEC Polynomial Coefficients C_{01} (SV M_{sat})	± 40.94	12	0.02	TECU /deg	-40.96 indicates data not available
STEC Polynomial Coefficients C_{10} (SV M_{sat})	± 40.94	12	0.02	TECU /deg	-40.96 indicates data not available
STEC Polynomial Coefficients C_{11} (SV M_{sat})	± 10.22	10	0.02	TECU /deg ²	-10.24 indicates data not available

(iv) STEC correction type = 3

DF Name	DF Range	BIT	LSB	DF Unit	Note
SSR STEC Quality Indicator(SV 1)	bits 5-3 : 0-7 bits 2-0 : 0-7	6	-	-	
STEC Polynomial Coefficients C_{00} (SV 1)	± 409.55	14	0.05	TECU	-409.6 indicates data not available
STEC Polynomial Coefficients C_{01} (SV 1)	± 40.94	12	0.02	TECU /deg	-40.96 indicates data not available
STEC Polynomial Coefficients C_{10} (SV 1)	± 40.94	12	0.02	TECU /deg	-40.96 indicates data not available
STEC Polynomial Coefficients C_{11} (SV 1)	± 10.22	10	0.02	TECU /deg ²	-10.24 indicates data not available
STEC Polynomial Coefficients C_{02} (SV 1)	± 0.635	8	0.005	TECU /deg ²	-6.4 indicates data not available
STEC Polynomial Coefficients C_{20} (SV 1)	± 0.635	8	0.005	TECU /deg ²	-6.4 indicates data not available
)					
SSR STEC Quality Indicator(SV M_{sat})	bits 5-3 : 0-7 bits 2-0 : 0-7	6	-	-	
STEC Polynomial Coefficients C_{00} (SV M_{sat})	± 409.55	14	0.05	TECU	-409.6 indicates data not available
STEC Polynomial Coefficients C_{01} (SV M_{sat})	± 40.94	12	0.02	TECU /deg	-40.96 indicates data not available
STEC Polynomial Coefficients C_{10} (SV M_{sat})	± 40.94	12	0.02	TECU /deg	-40.96 indicates data not available
STEC Polynomial Coefficients C_{11} (SV M_{sat})	± 10.22	10	0.02	TECU /deg ²	-10.24 indicates data not available
STEC Polynomial Coefficients C_{02} (SV M_{sat})	± 0.635	8	0.005	TECU /deg ²	-6.4 indicates data not available
STEC Polynomial Coefficients C_{20} (SV M_{sat})	± 0.635	8	0.005	TECU /deg ²	-6.4 indicates data not available

- (1) Compact SSR STEC correction type
STEC correction type for 0-2 as listed in Table 4.1.2-25.
- (2) Compact Network ID
Network ID to identify specific local correction messages.
- (3) Network SV mask
Bit stream used to select specific satellite set.
- (4) SSR STEC Quality Indicator
SSR STEC quality indicator. The definition is the same as that for SSR URA whereas the dimension is TECU instead of m. The SSR STEC quality indicator is computed as described in 5.4.3.
- (5) STEC Polynomial Coefficients (C_{00} , C_{01} , C_{10} , C_{11} , C_{02} , C_{20})
Coefficients are used to define STEC in a specific local or regional network, as defined in Table 4.1.2-25. Table 4.1.2-26 defines C_{00} , C_{01} , C_{10} , C_{11} , C_{02} , and C_{20} Where ϕ is the latitude of the user, λ is the longitude of the user, ϕ_0 is the latitude of the reference, and λ_0 is longitude of the reference.

Table 4.1.2-26 Definition of STEC polynomial coefficients (C_{00} , C_{01} , C_{10} , C_{11} , C_{02} , C_{20})

STEC Correction Type	STEC Network Correction
0	$\delta I_{ai} = C_{00}$
1	$\delta I_{ai} = C_{00} + C_{01}(\phi - \phi_0) + C_{10}(\lambda - \lambda_0)$
2	$\delta I_{ai} = C_{00} + C_{01}(\phi - \phi_0) + C_{10}(\lambda - \lambda_0) + C_{11}(\phi - \phi_0)(\lambda - \lambda_0)$
3	$\delta I_{ai} = C_{00} + C_{01}(\phi - \phi_0) + C_{10}(\lambda - \lambda_0) + C_{11}(\phi - \phi_0)(\lambda - \lambda_0) + C_{02}(\phi - \phi_0)^2 + C_{20}(\lambda - \lambda_0)^2$

4.1.2.2.10 Sub Type 9 – Compact SSR Gridded Correction Message

The sub type 9 message structure is shown in Figure 4.1.2-11. The message header and grid-specific part are defined in Table 4.1.2-27 and Table 4.1.2-28, respectively.

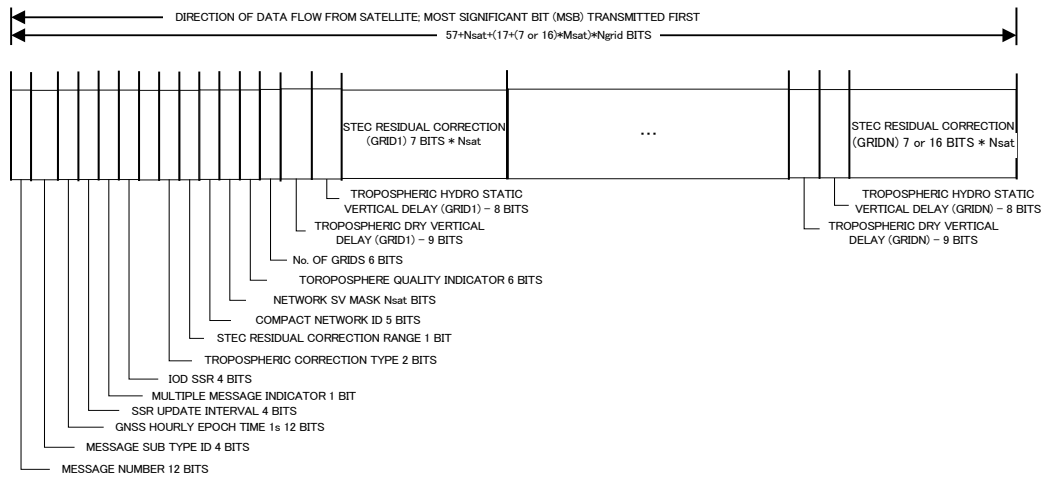

Figure 4.1.2-11 Compact SSR Gridded Correction Message structure

Table 4.1.2-27 Contents of message header, Compact SSR Gridded Correction Message

DF Name	DF Range	BIT	LSB	DF Unit	Note
Message Number	0-4095	12	-	-	4073
Message Sub Type ID	0-15	4	-	-	9
GNSS Hourly Epoch Time 1s	0-3599	12	1	s	3600-4095 indicates data not available
SSR Update Interval	0-15	4	1	-	
Multiple Message Indicator	-	1	-	-	
IOD SSR	0-15	4	1	-	
Tropospheric Correction Type	0-3	2	1	-	
STEC Residual Correction Range	0-1	1	1	-	
Compact Network ID	0-31	5	1	-	0 - undefined
Network SV mask	-	N_{sat}	-	-	
Troposphere Quality Indicator	bits 5-3 : 0-7 bits 2-0 : 0-7	6	-	-	
No. of Grids	0-63	6	1	-	

Table 4.1.2-28 Contents of grid-specific part of compact SSR Gridded Correction Message

DF Name	DF Range	BIT	LSB	DF Unit	Note
Tropospheric Hydro-Static Vertical Delay(Grid 1)	±1.02	9	0.004	m	-1.024 indicates data not available
Tropospheric Wet Vertical Delay(Grid 1)	±0.508	8	0.004	m	-0.512 indicates data not available
STEC Residual Correction (Grid 1)(SV 1)	±2.52 or ±1310.68	7 or 16	0.04	TECU	-2.56 indicates data not available or -1310.72 indicates data not available
}					
STEC Residual Correction (Grid 1)(SV M _{sat})	±2.52 or ±1310.68	7 or 16	0.04	TECU	-2.56 indicates data not available or -1310.72 indicates data not available
}					
Tropospheric Hydro Static Vertical Delay (Grid N)	±1.02	9	0.004	m	-1.024 indicates data not available
Tropospheric Wet Vertical Delay (Grid N)	±0.508	8	0.004	m	-0.512 indicates data not available
STEC Residual Correction (Grid N)(SV 1)	±2.52 or ±1310.68	7 or 16	0.04	TECU	-2.56 indicates data not available or -1310.72 indicates data not available
}					
STEC Residual Correction (Grid N)(SV M _{sat})	±2.52 or ±1310.68	7 or 16	0.04	TECU	-2.56 indicates data not available or -1310.72 indicates data not available

(1) Tropospheric Correction Type

It defines the nominal value of the hydrostatic and wet term and utilized mapping function for the calculation of troposphere slant delay.

0: Tropospheric correction is not included.

1: Constant offset 2.3 is used for the hydrostatic term, 0.252 is used for the wet term and Neill mapping function is used.

2-3: Reserved.

(2) STEC Residual Correction Range

Bit 7 if it is set to 0, otherwise bit 16 is used for STEC residual correction.

Table 4.1.2-29 Diff mode (STEC residual correction range = 0)

DF Name	DF Range	BIT	LSB	DF Unit	Note
STEC Residual Correction	±2.52	7	0.04	TECU	-2.56 indicates data not available

Table 4.1.2-30 Standalone mode (STEC residual correction range = 1)

DF Name	DF Range	BIT	LSB	DF Unit	Note
STEC Residual Correction	±1310.68	16	0.04	TECU	-1310.72 indicates data not available

(3) Troposphere Quality Indicator

Quality indicator of troposphere. Definition is the same as that for SSR URA. The troposphere quality indicator is computed as described in 5.4.3.

(4) Tropospheric Hydro-Static Vertical Delay

Variation in the hydro static tropospheric vertical delay relative to the nominal value. The constant nominal value, 2.3 m, is applied if the tropospheric correction type is equal to 1. The other types are reserved.

(5) Tropospheric Wet Vertical Delay

Variation in the wet tropospheric vertical delay relative to the nominal value. The constant nominal value, 0.252 m, is applied if the tropospheric correction type is equal to 1.

(6) STEC Residual Correction

If the STEC residual correction range is set to 0, the STEC residual correction is int7. Otherwise it is int16.

4.1.2.2.11 Sub Type 10 – Service Information

The sub type 10 message structure is shown in Figure 4.1.2-12. The message is defined in Table 4.1.2-30. Some constant or slowly changing data such as coordinate transformation parameters or reference grid position of sub type 9 are broadcasted as Service Information Packet by utilizing one or more messages of this sub type.

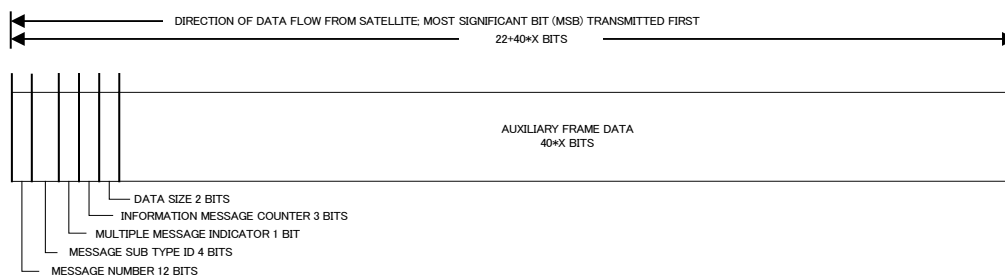

Figure 4.1.2-12 Compact SSR Service Information Message structure

Table 4.1.2-31 Contents of Compact SSR Service Information Message

DF Name	DF Range	BIT	LSB	DF Unit	Note
Message Number	0-4095	12	-	-	4073
Message Sub Type ID	0-15	4	-	-	10
Multiple Message Indicator	-	1	-	-	
Information Message Counter	0-7	3	1	-	
Data Size	0-3	2	1	-	
Auxiliary Frame Data	-	40*X	-	-	X is (Data Size + 1)

(1) Information Message Counter

Incremental counter for successive service information messages.

This counter counts up (0,1,2,...,7) in the sequence of multiple chunks of Auxiliary Frame Data for the specific Service Information Packet. When the content of the Service Information Packet has changed, the Information Message Counter shall be reset to zero (0). The maximum length of Service Information Packet is 1,280bits (160 bytes).

(2) Data Size

Indicator for specifying data size for Auxiliary Frame Data per one message.

(3) Auxiliary Frame Data

Data for constructing Service Information Packet.

The length of Auxiliary Frame Data is (DataSize+1) multiplied by 40 bits. The maximum length of Auxiliary Frame Data is 160bits (20 bytes). The Multiple Message Indicator is set to zero (0) in the last part of Auxiliary Frame Data, otherwise set to one (1).

The Service Information Packet structure is shown in Figure 4.1.2-13. The Service Information Packet shall be transferred by decomposing to the one or more Auxiliary Frame Data, it should be recovered on the user receivers by concatenating the multiple Auxiliary Frame Data. The detailed specification of Service Information Packet for CLAS is TBD.

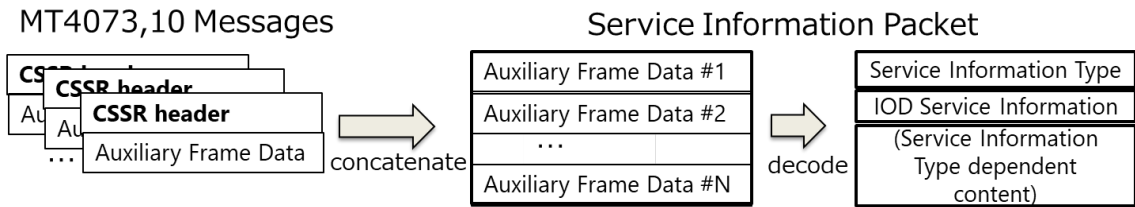

Figure 4.1.2-13 Service Information Packet structure

The contents of header part of Service Information Packet is defined in Table 4.1.2-31. The Service Information Packet always starts from the Service Information Type and the IOD Service Information. The content of the Service Information Packet can be identified by the Service Information Type and the IOD Service Information. When users missing some part of the successive Auxiliary Frame Data, it can be recovered by receiving the missing part in the next repeating data stream with the same Service Information Type and IOD Service Information.

Table 4.1.2-32 Contents of header part of Service Information Packet

DF Name	DF Range	BIT	LSB	DF Unit	Note
Service Information Type	0-15	4	-	-	
IOD Service Information	0-7	3	-	-	
(the remaining part of the header)	-	-	-	-	It depends on the value of Service Information Type

4.1.2.2.12 Sub Type 11 – Compact SSR GNSS Combined Correction

The sub type 11 message structure is shown in Figure 4.1.2-14. The message header and satellite-specific part are defined in Table 4.1.2-33 and Table 4.1.2-33, respectively.

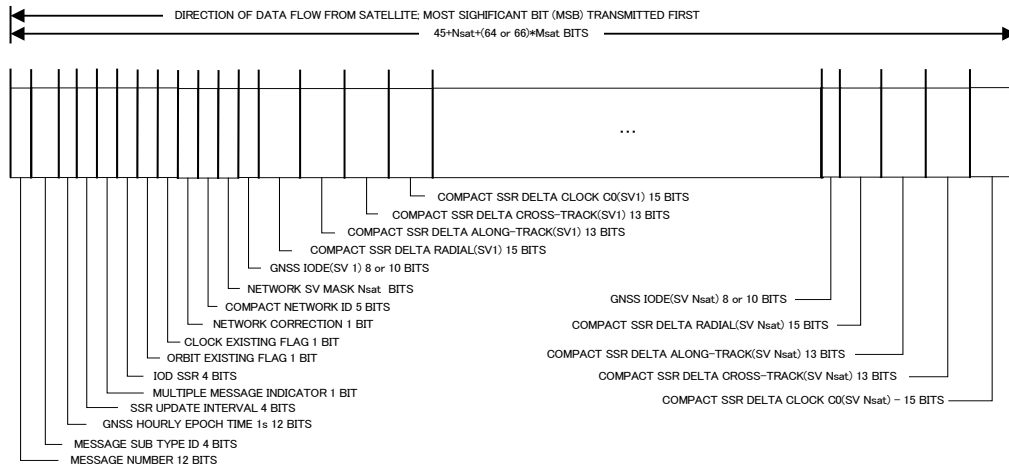

Figure 4.1.2-14 Compact SSR GNSS Combined Correction Message structure

Table 4.1.2-33 Contents of message header, Compact SSR GNSS Combined Correction Message

DF Name	DF Range	BIT	LSB	DF Unit	Note
Message Number	0-4095	12	-	-	4073
Message Sub Type ID	0-15	4	-	-	11
GNSS Hourly Epoch Time 1s	0-3599	12	1	s	3600-4095 indicates data not available
SSR Update Interval	0-15	4	1	-	
Multiple Message Indicator	-	1	-	-	
IOD SSR	0-15	4	1	-	
Orbit Existing Flag	-	1	-	-	
Clock Existing Flag	-	1	-	-	
Network Correction	-	1	-	-	
Compact Network ID	0-31	5	1	-	Included only if "Network Correction" equals to "1" 0 - undefined
Network SV Mask	-	N_{sat}	1	-	Included only if "Network Correction" equals to "1"

Table 4.1.2-34 Contents of satellite-specific part of Compact SSR GNSS Combined Correction Message

DF Name	DF Range	BIT	LSB	DF Unit	Note
GNSS IODE(SV 1)	0-255 or 0-1023	8 or 10	1	-	Included only if "Orbit Existing Flag" equals to "1"
Compact SSR Delta Radial(SV 1)	±26.2128	15	0.0016	m	Included only if "Orbit Existing Flag" equals to "1" -26.2144 indicates data not available
Compact SSR Delta Along-Track(SV 1)	±26.208	13	0.0064	m	Included only if "Orbit Existing Flag" equals to "1" -26.2144 indicates data not available
Compact SSR Delta Cross-Track(SV 1)	±26.208	13	0.0064	m	Included only if "Orbit Existing Flag" equals to "1" -26.2144 indicates data not available
Compact SSR Delta Clock C0(SV1)	±26.2128	15	0.0016	m	Included only if "Clock Existing Flag" equals to "1" -26.2144 indicates data not available
}					
GNSS IODE(SV M _{sat})	0-255 or 0-1023	8 or 10	1	-	Included only if "Orbit Existing Flag" equals to "1"
Compact SSR Delta Radial (SV M _{sat})	±26.2128	15	0.0016	m	Included only if "Orbit Existing Flag" equals to "1" -26.2144 indicates data not available
Compact SSR Delta Along-Track (SV M _{sat})	±26.208	13	0.0064	m	Included only if "Orbit Existing Flag" equals to "1" -26.2144 indicates data not available
Compact SSR Delta Cross-Track (SV M _{sat})	±26.208	13	0.0064	m	Included only if "Orbit Existing Flag" equals to "1" -26.2144 indicates data not available
Compact SSR Delta Clock C0(SV M _{sat})	±26.2128	15	0.0016	m	Included only if "Clock Existing Flag" equals to "1" -26.2144 indicates data not available

(1) Orbit Existing Flag

If the flag set to "1"_(B), "GNSS IODE", "Compact SSR Delta Radial", "Compact SSR Along-Track", and "Compact SSR Delta Cross-track" are included.

(2) Clock Existing Flag

If the flag set to "1"_(B), "Compact SSR Delta Clock C0" is included.

(3) Network Correction

If the flag set to "1"_(B), the state parameters "Compact SSR Delta Clock C0" or/and "GNSS IODE", "Compact SSR Delta Radial", "Compact SSR Along-Track", and "Compact SSR Delta Cross-track" in local network should be used in exchange of the state parameters included in Sub Type 2 or 3.

4.1.2.2.13 Sub Type 12 – Compact SSR Atmospheric Correction

The sub type 12 message is a combined message including contents of STEC Correction (Sub Type 8) and Gridded Correction (Sub Type 9). The message consists of a header, a tropospheric correction part, and a STEC correction part. The sub type 12 message structure is shown in Figure 4.1.2-15 and Table 4.1.2-34. The message header, the tropospheric correction part and the STEC correction part are defined in Table 4.1.2-35, Table 4.1.2-36 and Table 4.1.2-37, respectively.

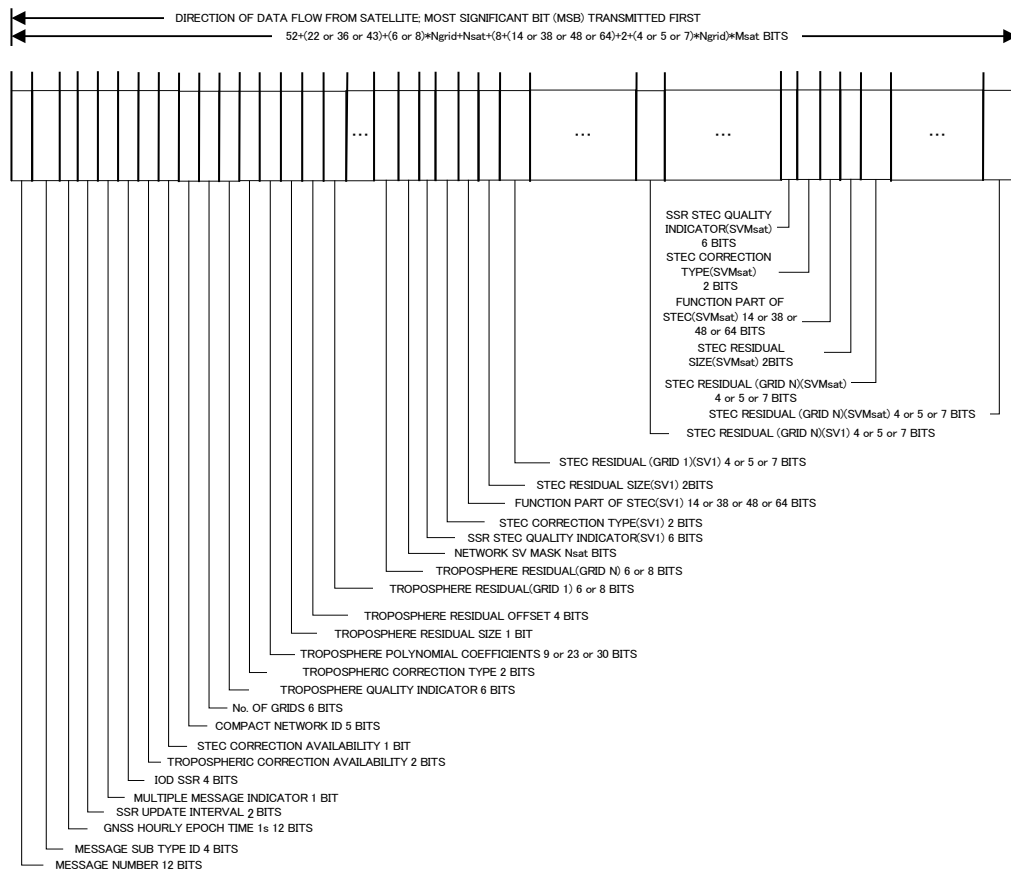

Figure 4.1.2-15 Compact SSR Atmospheric Correction

Table 4.1.2-35 Structure of Compact SSR Atmospheric Correction

DF Name	DF Range	BIT	LSB	DF Unit	Note
Header Part	-	-	-	-	Defined in Table 4.1.2-35
Tropospheric Correction Part	-	-	-	-	Defined in Table 4.1.2-36 Included only if "Tropospheric Correction Availability" is not zero.
STEC Correction Part	-	-	-	-	Defined in Table 4.1.2-37 Included only if "STEC Correction Availability" is not zero.

Table 4.1.2-36 Contents of message header, Compact SSR Atmospheric Correction Message

DF Name	DF Range	BIT	LSB	DF Unit	Note
Message Number	0-4095	12	-	-	4073
Message Sub Type ID	0-15	4	-	-	12
GNSS Hourly Epoch Time 1s	0-3599	12	1	s	3600-4095 indicates data not available
SSR Update Interval	0-15	4	1	-	
Multiple Message Indicator	-	1	-	-	
IOD SSR	0-15	4	1	-	
Tropospheric Correction Availability	0-3	2	-	-	
STEC Correction Availability	0-3	2	-	-	
Compact Network ID	0-31	5	1	-	0 - undefined
No. of Grids	0-63	6	1	-	

Table 4.1.2-37 Contents of tropospheric correction part, Compact SSR Atmospheric Correction Message
(i) Tropospheric Correction Type = 0

DF Name	DF Range	BIT	LSB	DF Unit	Note
Troposphere Quality Indicator	-	6	-	-	
Tropospheric Correction Type	0-3	2	1	-	
Troposphere Polynomial Coefficients T_{00}	± 1.02	9	0.004	m	-1.024 indicates data not available
Troposphere Residual Size	0-1	1	-	-	It specifies the size of Tropospheric Residual for 0: 6bit, 1: 8bit
Troposphere Residual Offset	0-0.30m	4	0.02	m	
Troposphere Residual (Grid 1)	± 0.124 or ± 0.508	6 or 8	0.004	m	-0.128 or -0.512 indicate data not available
}					
Troposphere Residual (Grid N)	± 0.124 or ± 0.508	6 or 8	0.004	m	-0.128 or -0.512 indicate data not available

(ii) Tropospheric Correction Type = 1

DF Name	DF Range	BIT	LSB	DF Unit	Note
Troposphere Quality Indicator	-	6	-	-	
Tropospheric Correction Type	0-3	2	1	-	
Troposphere Polynomial Coefficients T_{00}	± 1.02	9	0.004	m	-1.024 indicates data not available
Troposphere Polynomial Coefficients T_{01}	± 0.126	7	0.002	m/deg	-0.128 indicates data not available
Troposphere Polynomial Coefficients T_{10}	± 0.126	7	0.002	m/deg	-0.128 indicates data not available
Troposphere Residual Size	0-1	1	-	-	It specifies the size of Tropospheric Residual for 0: 6bit, 1: 8bit
Troposphere Residual Offset	0-0.30m	4	0.02	m	
Troposphere Residual (Grid 1)	± 0.124 or ± 0.508	6 or 8	0.004	m	-0.128 or -0.512 indicate data not available
λ					
Troposphere Residual (Grid N)	± 0.124 or ± 0.508	6 or 8	0.004	m	-0.128 or -0.512 indicate data not available

(iii) Tropospheric Correction Type = 2

DF Name	DF Range	BIT	LSB	DF Unit	Note
Troposphere Quality Indicator	-	6	-	-	
Tropospheric Correction Type	0-3	2	1	-	
Troposphere Polynomial Coefficients T_{00}	± 1.02	9	0.004	m	-1.024 indicates data not available
Troposphere Polynomial Coefficients T_{01}	± 0.126	7	0.002	m/deg	-0.128 indicates data not available
Troposphere Polynomial Coefficients T_{10}	± 0.126	7	0.002	m/deg	0.128 indicates data not available
Troposphere Polynomial Coefficients T_{11}	± 0.063	7	0.001	m/deg ²	-0.064 indicates data not available
Troposphere Residual Size	0-1	1	-	-	It specifies the size of Tropospheric Residual for 0: 6bit, 1: 8bit
Troposphere Residual Offset	0-0.30m	4	0.02	m	
Troposphere Residual (Grid 1)	± 0.124 or ± 0.508	6 or 8	0.004	m	-0.128 or -0.512 indicate data not available
λ					
Troposphere Residual (Grid N)	± 0.124 or ± 0.508	6 or 8	0.004	m	-0.128 or -0.512 indicate data not available

Table 4.1.2-38 Contents of STEC correction part, Compact SSR Atmospheric Correction Message

DF Name	DF Range	BIT	LSB	DF Unit	Note
Network SV Mask	-	N_{sat}	1	-	
SSR STEC Quality Indicator(SV 1)	bits 5-3 : 0-7 bits 2-0 : 0-7	6	-	-	
STEC Correction Type(SV 1)	0-3	2	1		
Functional Part of STEC(SV 1)	-	-	-	-	Defined in Table 4.1.2-38
STEC Residual Size (SV 1)	0-3	2	-	-	It specifies the size of STEC Residual
STEC Residual (Grid 1)(SV 1)	-	-	-	-	Defined in Table 4.1.2-39
)					
STEC Residual (Grid N)(SV 1)	-	-	-	-	Defined in Table 4.1.2-39
)					
SSR STEC Quality Indicator(SV M_{sat})	bits 5-3 : 0-7 bits 2-0 : 0-7	6	-	-	
STEC Correction Type (SV M_{sat})	0-3	2	1		
Functional Part of STEC(SV M_{sat})	-	-	-	-	Defined in Table 4.1.2-38
STEC Residual Size (SV M_{sat})	0-3	2	-	-	It specifies the size of STEC Residual
STEC Residual (Grid 1)(SV M_{sat})	-	-	-	-	Defined in Table 4.1.2-39
)					
STEC Residual (Grid N)(SV M_{sat})	-	-	-	-	Defined in Table 4.1.2-39

Table 4.1.2-39 Contents of Functional Part of STEC

(i) STEC Correction Type = 0

DF Name	DF Range	BIT	LSB	DF Unit	Note
STEC Polynomial Coefficients C_{00}	± 409.55	14	0.05	TECU	-409.6 indicates data not available

(ii) STEC Correction Type = 1

DF Name	DF Range	BIT	LSB	DF Unit	Note
STEC Polynomial Coefficients C_{00}	± 409.55	14	0.05	TECU	-409.6 indicates data not available
STEC Polynomial Coefficients C_{01}	± 40.94	12	0.02	TECU /deg	-40.96 indicates data not available
STEC Polynomial Coefficients C_{10}	± 40.94	12	0.02	TECU /deg	-40.96 indicates data not available

(iii) STEC Correction Type = 2

DF Name	DF Range	BIT	LSB	DF Unit	Note
STEC Polynomial Coefficients C_{00}	± 409.55	14	0.05	TECU	-409.6 indicates data not available
STEC Polynomial Coefficients C_{01}	± 40.94	12	0.02	TECU /deg	-40.96 indicates data not available
STEC Polynomial Coefficients C_{10}	± 40.94	12	0.02	TECU /deg	-40.96 indicates data not available
STEC Polynomial Coefficients C_{11}	± 10.22	10	0.02	TECU /deg ²	-10.24 indicates data not available

(iv) STEC Correction Type = 3

DF Name	DF Range	BIT	LSB	DF Unit	Note
STEC Polynomial Coefficients C_{00}	± 409.55	14	0.05	TECU	-409.6 indicates data not available
STEC Polynomial Coefficients C_{01}	± 40.94	12	0.02	TECU /deg	-40.96 indicates data not available
STEC Polynomial Coefficients C_{10}	± 40.94	12	0.02	TECU /deg	-40.96 indicates data not available
STEC Polynomial Coefficients C_{11}	± 10.22	10	0.02	TECU /deg ²	-10.24 indicates data not available
STEC Polynomial Coefficients C_{02}	± 0.635	8	0.005	TECU /deg ²	-0.64 indicates data not available
STEC Polynomial Coefficients C_{20}	± 0.635	8	0.005	TECU /deg ²	-0.64 indicates data not available

Table 4.1.2-40 Contents of STEC Residual

(i) STEC Residual Size = 0

DF Name	DF Range	BIT	LSB	DF Unit	Note
STEC Residual	±0.28	4	0.04	TECU	-0.32 indicate data not available

(ii) STEC Residual Size = 1

DF Name	DF Range	BIT	LSB	DF Unit	Note
STEC Residual	±0.84	4	0.12	TECU	-0.96 indicate data not available

(iii) STEC Residual Size = 2

DF Name	DF Range	BIT	LSB	DF Unit	Note
STEC Residual	±2.4	5	0.16	TECU	-2.56 indicate data not available

(iv) STEC Residual Size = 3

DF Name	DF Range	BIT	LSB	DF Unit	Note
STEC Residual	±15.12	7	0.24	TECU	-15.36 indicate data not available

(1) Tropospheric Correction Availability

If it is not set to zero, the tropospheric correction part shown in Table 4.1.2-36 is included. If both bit(0) and bit(1) are set to zero, the tropospheric correction part is not included.

If bit(0) is set to “1”_(B), the hydrostatic term which consist of “Tropospheric Correction Type” and “Troposphere Polynomial Coefficients” is included. If bit(0) is set to “0”_(B), the hydrostatic term which consist of “Tropospheric Correction Type” and “Troposphere Polynomial Coefficients” is not included.

If bit(1) is set to “1”_(B), the wet term which consists of “Troposphere Residual Size”, “Troposphere Residual Offset” and “Troposphere Residual” is included. If bit(1) is set to “0”_(B), the wet term which consists of “Troposphere Residual Size” , “Troposphere Residual Offset” and “Troposphere Residual” is not included.

(2) STEC Correction Availability

Indicator for specifying the STEC correction part. Table 4.1.2-40 shows whether data fields of the functional part and the residual part are present or not. Note that both bit(0) and bit(1) is set to “1”_(B) which is fixed setting in CLAS.

Table 4.1.2-41 Nominal Transmission Pattern of Subtype

Bit(0)	Bit(1)	Functional Part	Residual Part
0	0	Not Included	Not Included
0	1	Not Included	Included
1	0	Included	Not Included
1	1	Included	Included

(3) Tropospheric Correction Type

Tropospheric correction type for 0-2 as shown in Table 4.1.2-36.

The correction type 3 is reserved.

(4) Troposphere Polynomial Coefficients (T_{00} , T_{01} , T_{10} , T_{11})

Coefficients are used to define the hydrostatic term of the troposphere delay in a specific local or regional network, as defined in Table 4.1.2-37. Table 4.1.2-38 defines T_{00} , T_{01} , T_{10} , and T_{11} . Where ϕ is the latitude of the user, λ is the longitude of the user, ϕ_0 is the latitude of the reference, and λ_0 is longitude of the reference.

Table 4.1.2-42 Definition of polynomial coefficients (T_{00} , T_{01} , T_{10} , T_{11})

Tropospheric Correction Type	Hidro-Static Tropospheric Correction
0	$\Delta T_{hs}=T_{00}$
1	$\Delta T_{hs}=T_{00}+T_{01}(\phi - \phi_0)+T_{10}(\lambda - \lambda_0)$
2	$\Delta T_{hs}=T_{00}+T_{01}(\phi - \phi_0)+T_{10}(\lambda - \lambda_0)+T_{11}(\phi - \phi_0)(\lambda - \lambda_0)$
3	reserved

(5) Troposphere Residual Size

It specifies the data size of “Troposphere Residual” for 0: 6bit, 1: 8bit.

(6) Troposphere Residual Offset

The constant value for the wet term of Tropospheric Correction.

(7) Troposphere Residual

The wet term of Tropospheric Correction for each grid.

(8) STEC Polynomial Coefficients (C_{00} , C_{01} , C_{10} , C_{11} , C_{02} , C_{20})

Coefficients are used to define STEC in a specific local or regional network, as defined in Table 4.1.2-39. Table 4.1.2-26 defines C_{00} , C_{01} , C_{10} , C_{11} , C_{02} , and C_{20} Where ϕ is the latitude of the user, λ is the longitude of the user, ϕ_0 is the latitude of the reference, and λ_0 is longitude of the reference.

(9) STEC Residual Size

It specifies the size of “STEC Residual” for 0: 4bit (LSB=0.04), 1: 4bit (LSB=0.12), 2:5bit (LSB=0.16), 3:7bit (LSB=0.24).

(10) STEC Residual

STEC Residual correction. The data size depends on “STEC Residual Size”.

4.1.2.2.14 Sub Type Transmission Pattern

Each sub type is transmitted at a rate of one cycle within 30 seconds, according to the transmission schedule. Table 4.1.2-43 and Figure 4.1.2-16 show a nominal pattern. Note that the user algorithm should not assume any specific pattern.

Table 4.1.2-43 Nominal Transmission Pattern of Subtype

Sec	Subframe Number	Sub Type	Compact Network ID
0-4	1	1,2,3,11,4,6,7,12	12,2
5-9	2	3,11,6,12	3,4
10-14	3	3,11,6,12	5,6
15-19	4	3,11,6,12	7,8
20-24	5	3,11,6,12	9,10
25-29	6	3,11,6,12	11,1

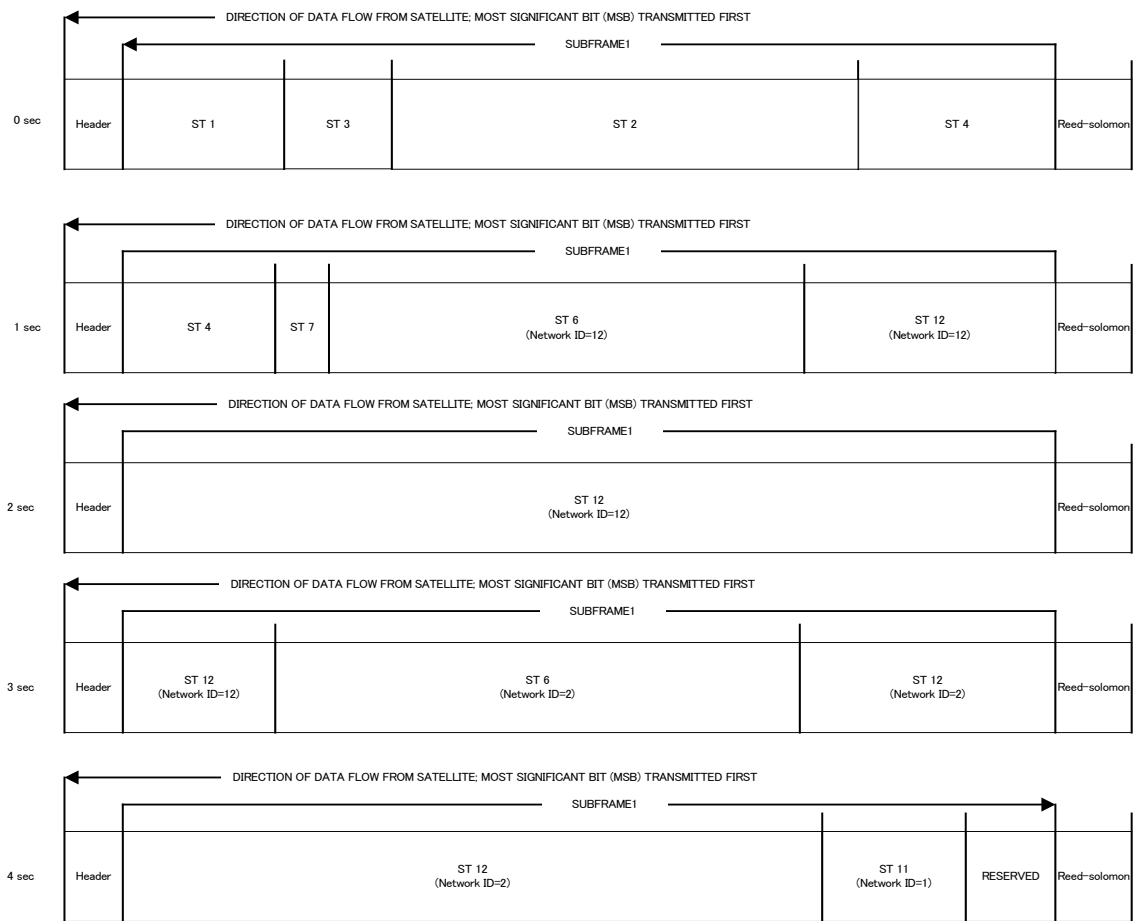

Figure 4.1.2-16 Subtype transmission pattern

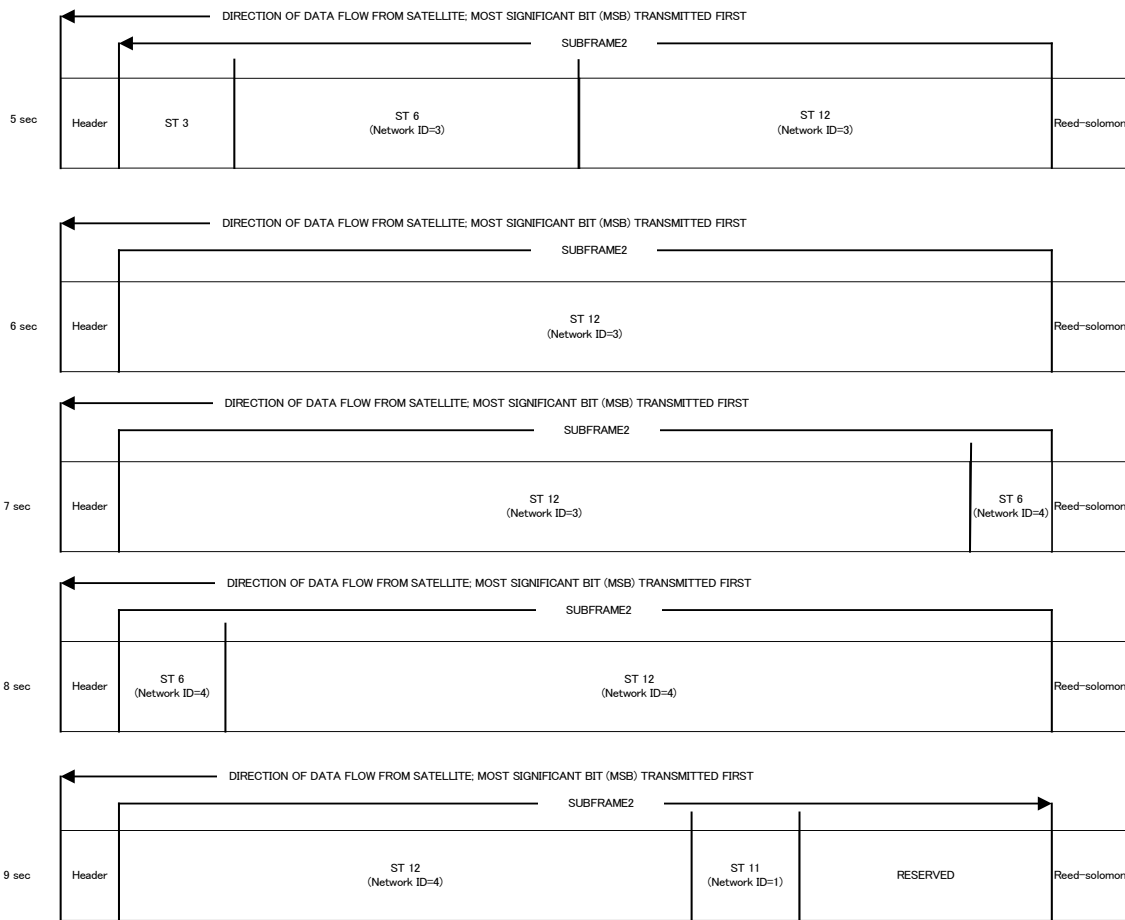

Figure 4.1.2-16 Subtype transmission pattern (continued)

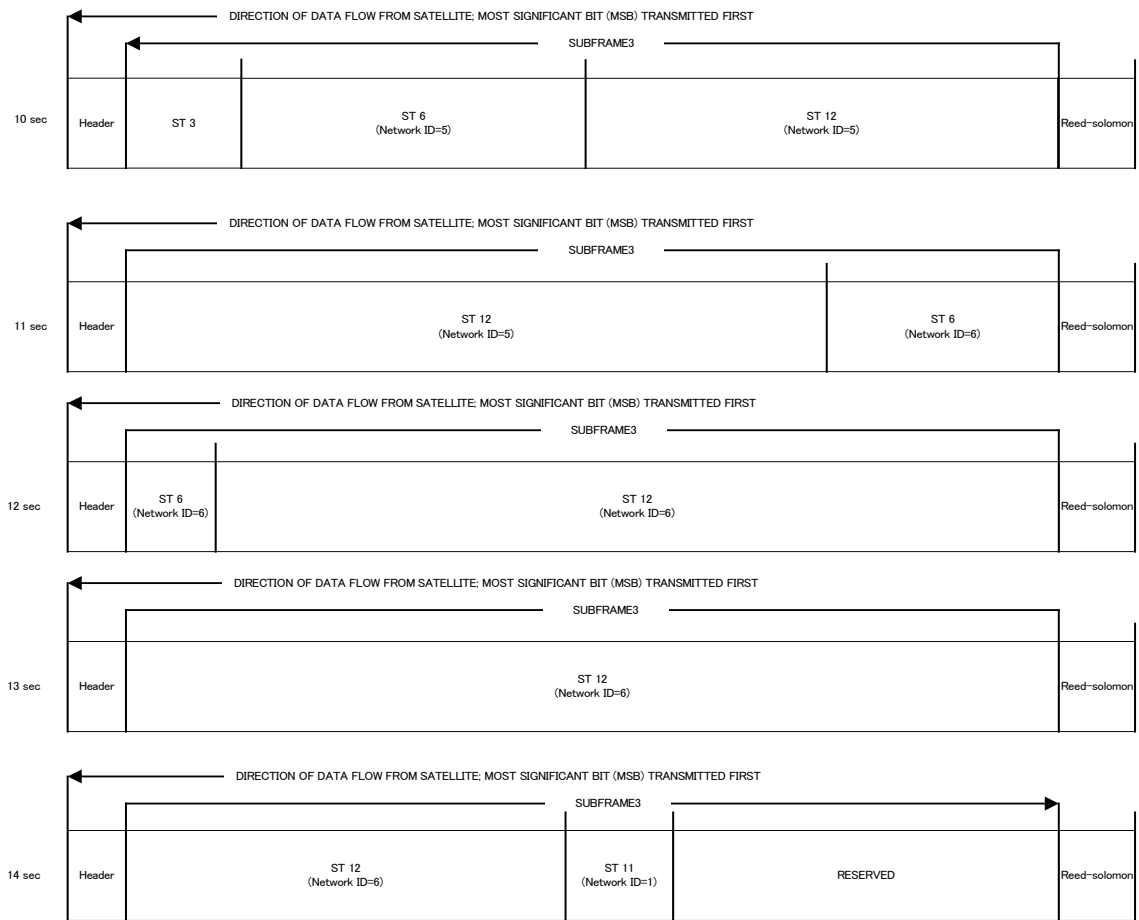

Figure 4.1.2-16 Subtype transmission pattern (continued)

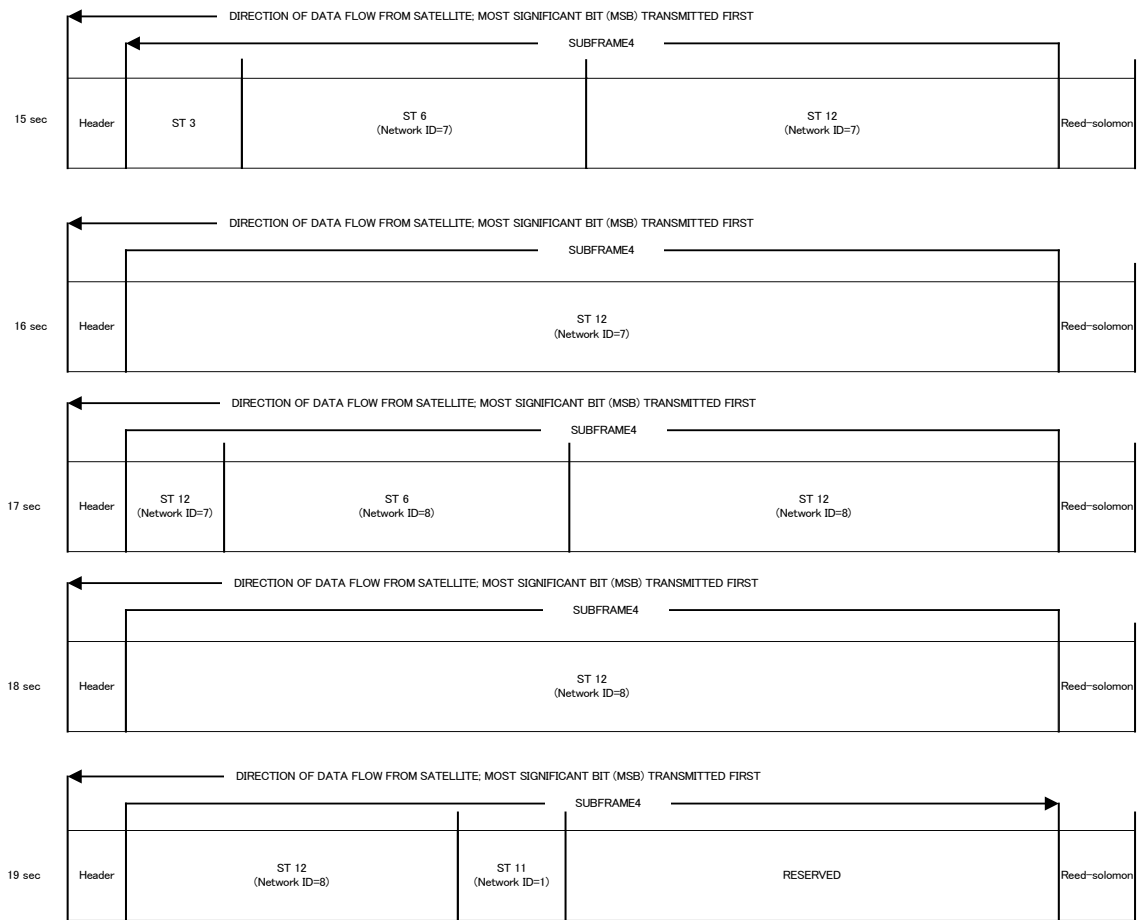

Figure 4.1.2-16 Subtype transmission pattern (continued)

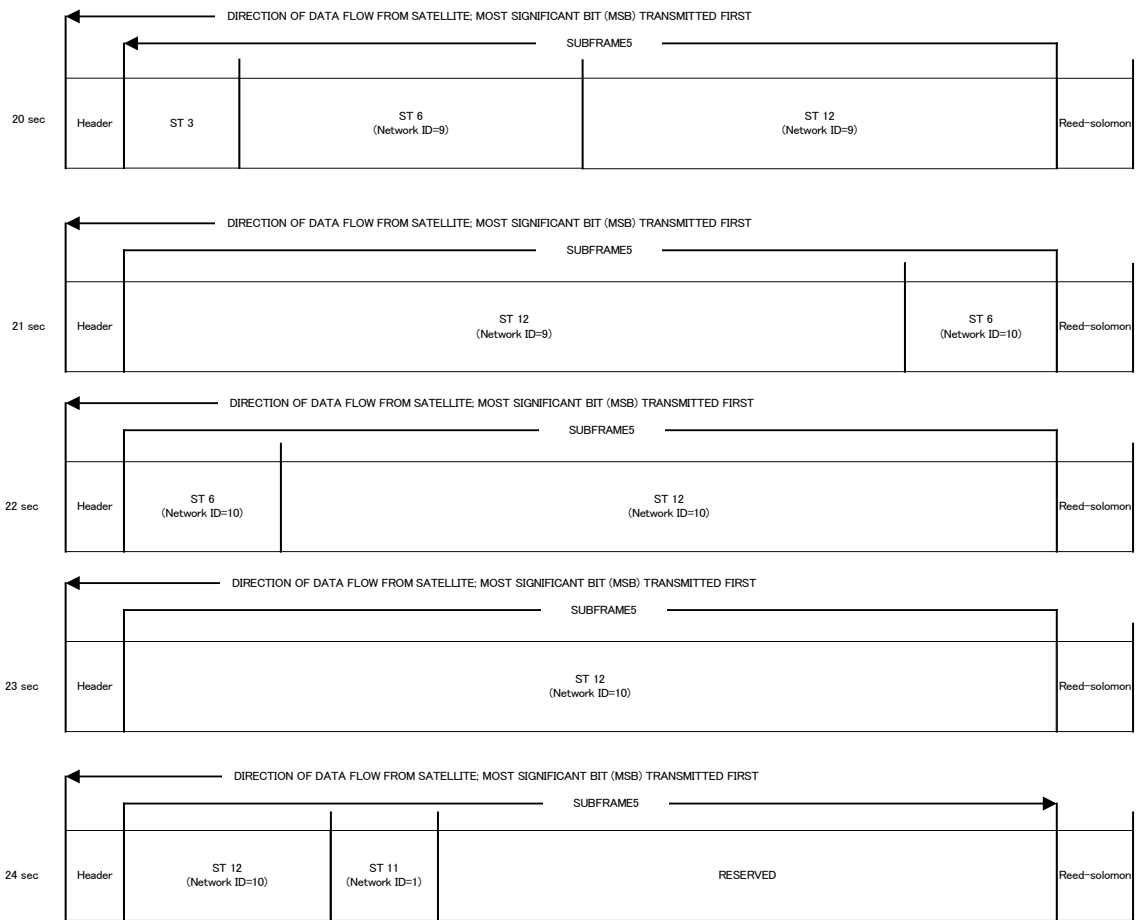

Figure 4.1.2-16 Subtype transmission pattern (continued)

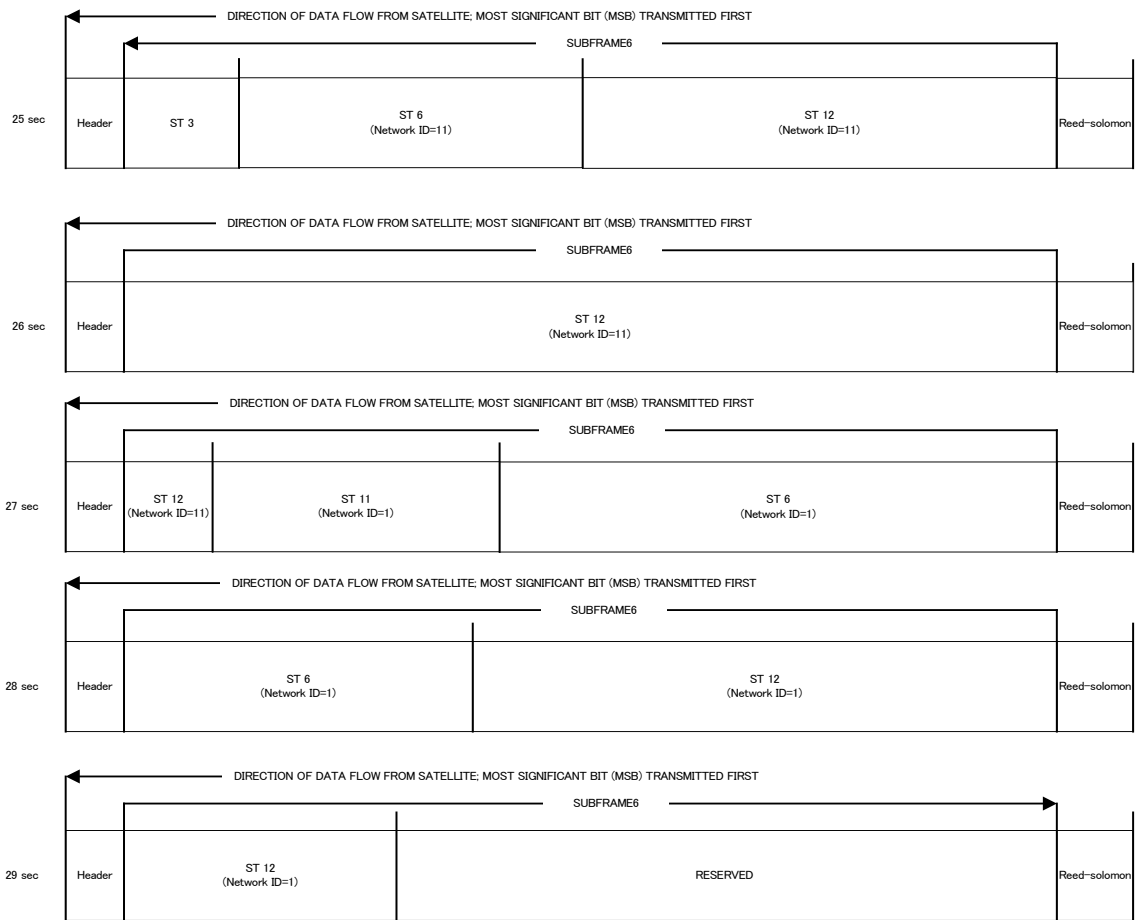

Figure 4.1.2-16 Subtype transmission pattern (continued)

4.1.2.3 Null Message

If there is no CLAS information to be transmitted, as determined by the satellite system side, a null message is sent. The nominal validity interval of each message after a null message is shown in Table 4.1.1-2. User can use the message within the nominal validity interval.

The following events are envisaged in the situation when there is no CLAS information to be transmitted.

- (1) The L6 positioning upload data from the ground system is not sent.

When an abnormality occurs in the ground system and system uplink disconnection occurs, the null message is transmitted.

- (2) Unintended L6 positioning upload data is transmitted to the satellite system.

When the L6 positioning upload data authentication becomes NG in the satellite system, the data is discarded and a null message is transmitted.

The preamble of the null message is a fixed value. PRN number is numbered (8-bit) with the PRN code to be used. Thus, the L6 message type ID is 0 and the Alert Flag is "1"_(B). The first 7-bit of the data part (1695-bit) are "0101010"_(B), and the other repeats the "10101010"_(B).

4.1.3. FEC Encoded Algorithm

Reed-Solomon (255, 223) encoding is applied to the 1744-bit of the navigation message (preamble, PRN, message type ID, alert flag, and data section). Every 8-bit of the resulting bit-stream constitutes one symbol. (See Section 4.1.2.3.1 for details)

To add the 32-symbol (256-bit) Reed-Solomon code to the 218-symbol (1744-bit) navigation message, nine "0" symbols (72-bit) are inserted at the beginning of the 214-symbol (1712-bit) data bit string that does not include the 4-symbol (32-bit) preamble at the beginning of the header. The resulting 223-symbol (1784-bit) data bit string (with the 9 zero symbols inserted) is Reed-Solomon encoded (255,223) to generate a 32-symbol (256-bit) parity word. The 250 symbols (2000-bit) that comprise the 32-symbol parity words added to the original 218-symbol (1744-bit) data bit string (including the preamble) are then input to the CSK modulator (see Figure 4.1.3-1).

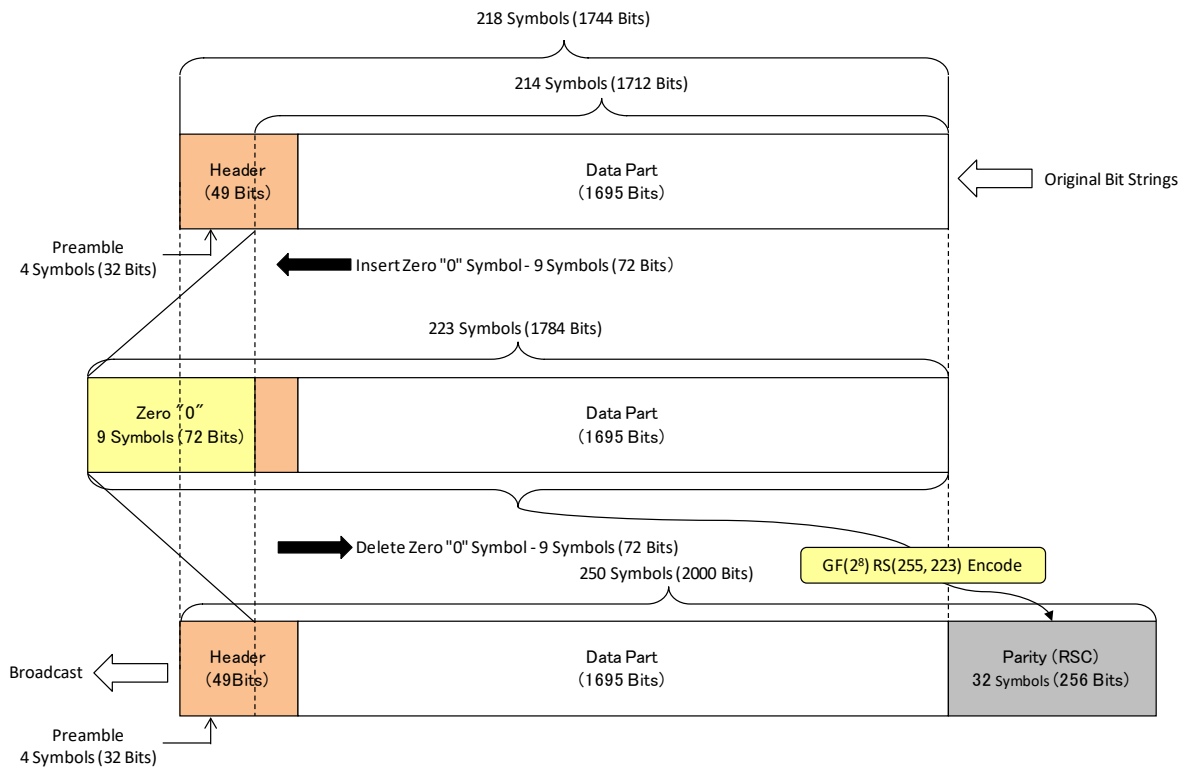

Figure 4.1.3-1 Compact SSR STEC correction message structure

4.1.3.1.1 Reed Solomon Coding/Decoding Algorithm for L6 Navigation Message

(1) Construct Galois Field $GF(2^8)$

We choose $F(x) = x^8 + x^7 + x^2 + x + 1$ as a primitive polynomial of degree 8 over \mathbf{Z}_2 . (Note that, because this is the binary case, addition (+) is equivalent to exclusive-OR (XOR) and multiplication (x) is equivalent to the logical AND operation.) When α is a root of $F(x) = 0$, we have the following (note that $\alpha^8 = -\alpha^8$ over \mathbf{Z}_2):

$$\alpha^8 = -\alpha^8 = \alpha^7 + \alpha^2 + \alpha + 1 \quad 4.1.3-1$$

From equation 4.1.3-1 any power of α can be represented by a linear combination of $\alpha^7, \alpha^6, \alpha^5, \alpha^4, \alpha^3, \alpha^2, \alpha^1, \alpha^0 (= 1)$ over \mathbf{Z}_2 (note that $\alpha^i + \alpha^i = 0$) as follows:

$$\begin{aligned} \alpha^8 &= \alpha^7 + \alpha^2 + \alpha + 1 \\ \alpha^9 &= \alpha^8 \times \alpha = \alpha^8 + \alpha^3 + \alpha^2 + \alpha \\ &= (\alpha^7 + \alpha^2 + \alpha + 1) + \alpha^3 + \alpha^2 + \alpha \\ &= \alpha^7 + \alpha^3 + 1 \\ \alpha^{10} &= \alpha^9 \times \alpha = \alpha^8 + \alpha^4 + \alpha \\ &= (\alpha^7 + \alpha^2 + \alpha + 1) + \alpha^4 + \alpha \\ &= \alpha^7 + \alpha^4 + \alpha^2 + 1 \\ &\vdots \\ \alpha^{254} &= \alpha^7 + \alpha^6 + \alpha + 1 \end{aligned} \quad 4.1.3-2$$

Then, the order of α is 255, since:

$$\begin{aligned} \alpha^{255} &= \alpha^{254} \times \alpha = \alpha^8 + \alpha^7 + \alpha^2 + \alpha \\ &= (\alpha^7 + \alpha^2 + \alpha + 1) + \alpha^7 + \alpha^2 + \alpha \\ &= 1 + \alpha^0 \end{aligned} \quad 4.1.3-3$$

From equations 4.1.3-3, the addition of two powers of α is as follows: When

$$\alpha^m = \mu_{m7}\alpha^7 + \mu_{m6}\alpha^6 + \dots + \mu_{m1}\alpha^1 + \mu_{m0} \quad 4.1.3-4$$

$$\alpha^n = \mu_{n7}\alpha^7 + \mu_{n6}\alpha^6 + \dots + \mu_{n1}\alpha^1 + \mu_{n0} \quad 4.1.3-5$$

the addition is given by:

$$\begin{aligned} \alpha^m + \alpha^n &= (\mu_{m7} + \mu_{n7})\alpha^7 + (\mu_{m6} + \mu_{n6})\alpha^6 + \\ &\quad \dots (\mu_{m1} + \mu_{n1})\alpha^1 + (\mu_{m0} + \mu_{n0})\alpha^0 \\ &= \alpha^1 \end{aligned} \quad 4.1.3-6$$

Each μ_{mi}, μ_{nj} coefficient is either a zero or a one, and $\mu_{mi} + \mu_{nj}$ is the logical "exclusive OR" of the two coefficients. As a result of the above operations, $\{0, 1 (= \alpha^0), \alpha^1, \alpha^2, \dots, \alpha^{254}\}$ makes a Galois Field $GF(2^8)$.

(2) Change of Basis

From equations 4.1.3-2, one basis for $\{0,1(=\alpha^0),\alpha^1,\alpha^2,\dots,\alpha^{254}\}$ over \mathbf{Z}_2 is the set $\{\alpha^7,\alpha^6,\alpha^5,\alpha^4,\alpha^3,\alpha^2,\alpha^1,\alpha^0\}$.

When $l_0 = \alpha^{125}, l_1 = \alpha^{88}, l_2 = \alpha^{226}, l_3 = \alpha^{163}, l_4 = \alpha^{46}, l_5 = \alpha^{184}, l_6 = \alpha^{67}, l_7 = \alpha^{242}$, the set $\{l_0, l_1, l_2, l_3, l_4, l_5, l_6, l_7\}$ is another basis for $\{0,1(=\alpha^0),\alpha^1,\alpha^2,\dots,\alpha^{254}\}$ over \mathbf{Z}_2 . When the nth power of α is represented by two linear combinations:

$$\begin{aligned}\alpha^n &= u_7\alpha^7 + u_6\alpha^6 + u_5\alpha^5 + u_4\alpha^4 + u_3\alpha^3 \\ &\quad + u_2\alpha^2 + u_1\alpha^1 + u_0\alpha^0 \\ &= z_0l_0 + z_1l_1 + z_2l_2 + z_3l_3 + z_4l_4 + z_5l_5 + z_6l_6 + z_7l_7\end{aligned}\tag{4.1.3-7}$$

The relationship between $u_7, u_6, u_5, u_4, u_3, u_2, u_1, u_0$ and $z_0, z_1, z_2, z_3, z_4, z_5, z_6, z_7$ is given by the following two equations:

$$(z_0, z_1, z_2, z_3, z_4, z_5, z_6, z_7) = \begin{pmatrix} u_7 \\ u_6 \\ u_5 \\ u_4 \\ u_3 \\ u_2 \\ u_1 \\ u_0 \end{pmatrix}^t \begin{pmatrix} 1 & 0 & 0 & 0 & 1 & 1 & 0 & 1 \\ 1 & 1 & 1 & 0 & 1 & 1 & 1 & 1 \\ 1 & 1 & 1 & 0 & 1 & 1 & 0 & 0 \\ 1 & 0 & 0 & 0 & 0 & 1 & 1 & 0 \\ 1 & 1 & 1 & 1 & 1 & 0 & 1 & 0 \\ 1 & 0 & 0 & 1 & 1 & 0 & 0 & 1 \\ 1 & 0 & 1 & 0 & 1 & 1 & 1 & 1 \\ 0 & 1 & 1 & 1 & 1 & 0 & 1 & 1 \end{pmatrix}\tag{4.1.3-8}$$

$$(u_7, u_6, u_5, u_4, u_3, u_2, u_1, u_0) = \begin{pmatrix} z_0 \\ z_1 \\ z_2 \\ z_3 \\ z_4 \\ z_5 \\ z_6 \\ z_7 \end{pmatrix}^t \begin{pmatrix} 1 & 1 & 0 & 0 & 0 & 1 & 0 & 1 \\ 0 & 1 & 0 & 0 & 0 & 0 & 1 & 0 \\ 0 & 0 & 1 & 0 & 1 & 1 & 1 & 0 \\ 1 & 1 & 1 & 1 & 1 & 1 & 0 & 1 \\ 1 & 1 & 1 & 1 & 0 & 0 & 0 & 0 \\ 0 & 1 & 1 & 1 & 1 & 0 & 0 & 1 \\ 1 & 0 & 1 & 0 & 1 & 1 & 0 & 0 \\ 1 & 1 & 0 & 0 & 1 & 1 & 0 & 0 \end{pmatrix}\tag{4.1.3-9}$$

Each u_i, z_j coefficient is either a zero or a one, and the addition of these matrix operations is simply "exclusive OR".

(3) Encoding

When the header and data parts of the L6 message are given, the Reed-Solomon encoding is performed as follows:

The target encoded length is 214 symbols (5 to 218) followed by the Preamble. Consider the bits in each symbol to be $z_0, z_1, z_2, z_3, z_4, z_5, z_6, z_7$ corresponding to the elements of $\{0, 1 (= \alpha^0), \alpha^1, \alpha^2, \dots, \alpha^{254}\}$ (see Section (2)). When the binary string 5th, 6th, ..., 218th symbol is represented by A_5, A_6, \dots, A_{218} ($A_i \in \{0, 1 (= \alpha^0), \alpha^1, \alpha^2, \dots, \alpha^{254}\}$) polynomial $I(x)$ over $\{0, 1 (= \alpha^0), \alpha^1, \alpha^2, \dots, \alpha^{254}\}$ defined as follows:

$$I(x) = A_5x^{213} + A_6x^{212} + \dots + A_{217}x + A_{218}$$

If the code generator polynomial over $\{0, 1 (= \alpha^0), \alpha^1, \alpha^2, \dots, \alpha^{254}\}$ is defined as follows:

$$g(x) = \prod_{j=112}^{143} (x - \alpha^{11j}) \quad 4.1.3-10$$

Then, $P(x)$ is the remainder after dividing $x^{32}I(x)$ by $g(x)$. Division is used for the operation of the Galois Field $\{0, 1 (= \alpha^0), \alpha^1, \alpha^2, \dots, \alpha^{254}\}$ (see Section (1)).

$P(x)$ is written as follows:

$$P(x) = B_1x^{31} + B_2x^{30} + \dots + B_{31}x + B_{32} \quad 4.1.3-11$$

$$B_i \in \{0, 1 (= \alpha^0), \alpha^1, \alpha^2, \dots, \alpha^{254}\}$$

When each B_i is represented by a linear combination of set $\{l_0, l_1, l_2, l_3, l_4, l_5, l_6, l_7\}$:

$$B_i = z_0l_0 + z_1l_1 + z_2l_2 + z_3l_3 + z_4l_4 + z_5l_5 + z_6l_6 + z_7l_7 \quad 4.1.3-12$$

The 32-symbol Reed-Solomon Code is generated by thinking of $z_0, z_1, z_2, z_3, z_4, z_5, z_6, z_7$ as the bits of the symbol.

(4) Decoding

Similarly, in Section (3), the polynomial $S(x)$ is generated as follows from the 5th to 250th symbols of the received message.

$$S(x) = A'_5 x^{245} + A'_6 x^{244} + \dots + A'_{249} x + A'_{250} \quad 4.1.3-13$$

Thus, by employing this R-S encoding/decoding, we can detect errors and correct those up until 16 symbol errors occur, by computing 32 polynomials $S(\alpha^{11j})$, $j = 112 \sim 143$. Provided there are no errors, $S(\alpha^{11j})$ is all zeroes.

4.1.4. Definition of GRID

Gridded Correction of Ionosphere and Troposphere information for subtype 9 is relative to the ellipsoid height 0 in the grid point. Table 4.1.4-1 shows the compact network ID and coordinates.

Network ID 12 is standalone. Sub type 9 is transmitted in ascending GRID No. These grid parameters are contained in the support file *clas_grid.def* file attached in this document as Appendix.

Table 4.1.4-1 Compact network ID and coordinates (1/6)

Compact Network ID	GRID No.	Latitude	Longitude
1	1	24.75	125.37
	2	24.83	125.17
	3	24.64	124.69
	4	24.54	124.30
	5	24.34	124.17
	6	24.06	123.80
	7	24.43	123.79
	8	24.45	122.94

Compact Network ID	GRID No.	Latitude	Longitude
2	1	26.42	126.87
	2	26.15	127.53
	3	26.69	127.53
	4	26.69	128.18
	5	27.23	128.18
	6	27.23	128.84
	7	27.77	128.51
	8	27.77	129.17
	9	28.30	129.17
	10	28.30	129.83
	11	25.83	131.23

Table 4.1.4-1 Compact network ID and coordinates (2/6)

Compact Network ID	GRID No.	Latitude	Longitude
3	1	33.16	129.50
	2	33.70	129.50
	3	34.23	129.50
	4	34.77	129.50
	5	34.23	128.84
	6	32.62	128.84
	7	33.16	128.84
	8	31.81	129.50
	9	31.00	130.49
	10	31.00	131.14
	11	30.46	130.49
	12	30.46	131.14
	13	31.54	130.16
	14	32.08	130.16
	15	32.62	130.16
	16	33.16	130.16
	17	33.70	130.16
	18	31.54	130.82
	19	32.08	130.82
	20	32.62	130.82
	21	33.16	130.82
	22	33.70	130.82
	23	31.54	131.47
	24	32.08	131.47
	25	32.62	131.47
	26	33.16	131.47
	27	33.70	131.47
	28	28.84	128.84
	29	28.84	129.50
	30	29.38	129.50
	31	29.92	129.50
	32	29.92	130.16

Compact Network ID	GRID No.	Latitude	Longitude
4	1	32.62	132.13
	2	33.16	132.13
	3	33.70	132.13
	4	32.62	132.79
	5	33.16	132.79
	6	33.70	132.79
	7	34.23	132.79
	8	33.16	133.45
	9	33.70	133.45
	10	34.23	133.45
	11	33.16	134.11
	12	33.70	134.11
	13	34.23	134.11
	14	33.70	134.76
	15	34.23	134.76

Table 4.1.4-1 Compact network ID and coordinates (3/6)

Compact Network ID	GRID No.	Latitude	Longitude
5	1	34.23	130.82
	2	34.23	131.47
	3	34.77	131.47
	4	34.23	132.13
	5	34.77	132.13
	6	34.77	132.79
	7	35.31	132.79
	8	34.77	133.45
	9	35.31	133.45
	10	35.85	132.79
	11	35.85	133.45
	12	36.39	133.45
	13	34.77	134.11
	14	35.31	134.11
	15	35.85	134.11

Compact Network ID	GRID No.	Latitude	Longitude
6	1	34.77	134.76
	2	35.31	134.76
	3	35.85	134.76
	4	33.70	135.42
	5	34.23	135.42
	6	34.77	135.42
	7	35.31	135.42
	8	35.85	135.42
	9	33.70	136.08
	10	34.23	136.08
	11	34.77	136.08
	12	35.31	136.08
	13	35.85	136.08
	14	36.39	136.08
	15	34.23	136.74
	16	34.77	136.74
	17	35.31	136.74
	18	35.85	136.74
	19	36.39	136.74
	20	36.93	136.74
	21	37.47	136.74
	22	34.77	137.40
	23	35.31	137.40
	24	35.85	137.40
	25	36.39	137.40
	26	36.93	137.40
	27	37.47	137.40

Table 4.1.4-1 Compact network ID and coordinates (4/6)

Compact Network ID	GRID No.	Latitude	Longitude
7	1	34.77	138.05
	2	35.31	138.05
	3	35.85	138.05
	4	36.39	138.05
	5	34.77	138.71
	6	35.31	138.71
	7	35.85	138.71
	8	36.39	138.71
	9	34.23	139.04
	10	34.23	139.70
	11	34.77	139.37
	12	35.31	139.37
	13	35.85	139.37
	14	36.39	139.37
	15	34.77	140.03
	16	35.31	140.03
	17	35.85	140.03
	18	36.39	140.03
	19	35.31	140.69
	20	35.85	140.69
	21	36.39	140.69
	22	33.11	139.79

Compact Network ID	GRID No.	Latitude	Longitude
8	1	36.93	138.05
	2	36.93	138.71
	3	37.47	138.71
	4	37.74	138.05
	5	38.28	138.05
	6	38.01	138.71
	7	36.93	139.37
	8	37.47	139.37
	9	38.01	139.37
	10	38.55	139.37
	11	36.93	140.03
	12	37.47	140.03
	13	38.01	140.03
	14	38.55	140.03
	15	36.93	140.69
	16	37.47	140.69
	17	38.01	140.69
	18	38.55	140.69
	19	37.47	141.34
	20	38.55	141.34

Table 4.1.4-1 Compact network ID and coordinates (5/6)

Compact Network ID	GRID No.	Latitude	Longitude
9	1	39.09	140.03
	2	39.62	140.03
	3	40.16	140.03
	4	40.70	140.03
	5	41.24	140.03
	6	39.09	140.69
	7	39.62	140.69
	8	40.16	140.69
	9	40.70	140.69
	10	41.24	140.69
	11	39.09	141.34
	12	39.62	141.34
	13	40.16	141.34
	14	40.70	141.34
	15	41.24	141.34
	16	39.09	142.00
	17	39.62	142.00
	18	40.16	142.00

Compact Network ID	GRID No.	Latitude	Longitude
10	1	42.32	139.37
	2	41.78	140.03
	3	42.32	140.03
	4	42.86	140.03
	5	41.78	140.69
	6	42.32	140.69
	7	42.86	140.69
	8	43.40	140.69
	9	41.78	141.34
	10	42.32	141.34
	11	42.86	141.34
	12	43.40	141.34
	13	43.94	141.34
	14	42.32	142.00
	15	42.86	142.00
	16	43.40	142.00
	17	43.94	142.00
	18	42.32	142.66
	19	42.86	142.66
	20	43.40	142.66
	21	41.78	143.32
	22	42.32	143.32
	23	42.86	143.32

Table 4.1.4-1 Compact network ID and coordinates (6/6)

Compact Network ID	GRID No.	Latitude	Longitude
11	1	45.28	141.34
	2	44.48	142.00
	3	45.01	142.00
	4	45.55	142.00
	5	43.94	142.66
	6	44.48	142.66
	7	45.01	142.66
	8	43.40	143.32
	9	43.94	143.32
	10	44.48	143.32
	11	42.86	143.98
	12	43.40	143.98
	13	43.94	143.98
	14	42.86	144.63
	15	43.40	144.63
	16	43.94	144.63
	17	43.40	145.29
	18	43.94	145.29
	19	44.48	145.29

Compact Network ID	GRID No.	Latitude	Longitude
12	1	27.07	142.20
	2	26.64	142.16

4.2. L6E Message (obsolete)

This section is obsolete, and L6E Message is defined in dedicated interface specification documents, IS-QZSS-MDC and IS-QZSS-SAS.

5. User Algorithms

5.1. Time System

The time system of QZSS is called QZSST and has the following characteristics.

(1) Definition

(a) One-second length

The length of one second is identical to International Atomic Time (TAI).

(b) Integer second offset for TAI

The integer second offset for TAI is the same as that for GPS and TAI is always 19 seconds ahead of QZSST.

(c) Starting point of week number for QZSST

The starting point of the week number for QZSST is identical to that for GPST (January 6, 1980).

(2) Time system of “Epoch Time” in compact SSR messages

Data field “GNSS Epoch Time 1s” or “GNSS Hourly Epoch Time 1s” in each compact SSR message, transmitted from QZS, are represented in QZSST.

5.2. Geodetic Datum

The geodetic datum in CLAS is defined as follows.

5.2.1. Ellipsoid

GRS80

5.2.2. Coordinate

ITRF2020 (IGb20)

5.2.3. Relationship with Japanese Geodetic Datum 2011

Positioning results obtained by utilizing CLAS are in the ITRF2020(IGb20) coordinate system which are realized at the current epoch based on the daily coordinate values (F5.1 solution) published by the Geospatial Information Authority of Japan (GSI).

In the case of obtaining positioning results expressed in ITRF94 or ITRF2008, defined in the static datum “Japanese Geodetic Datum 2011 (JGD2011)”, crustal movement transformations are necessary, which are used in ground-based RTK services or network RTK services in Japan (reference document (2), (3)).

5.3. Constants

5.3.1. Speed of Light

Expressed using a small letter "c". The value is $c = 299792458$ [m/s].

5.3.2. Circular Constant

Expressed using the Greek symbol " π ". The value is $\pi = 3.1415926535898$.

5.3.3. Angular Velocity of the Earth's Rotation

Expressed using the Greek symbol " $\dot{\Omega}_e$ ".

The value is $\dot{\Omega}_e = 7.2921151467 \times 10^{-5}$ [rad/s].

5.3.4. Earth's Gravitation Constant

Expressed using the Greek symbol " μ ". The value is $\mu = 3.986005 \times 10^{14}$ [m³/s²].

5.3.5. Semi-circle

Expressed using the circular constant " π ". $1[\text{semi-circle}] = \pi$ [rad]

5.4. Integrity

Integrity for CLAS is implemented with a flag-type-based method indicated in this section and a message-type-based method specified in the applicable document (2) and (3). Integrity information in CLAS consists of the Alert flag described in Section 5.4.1., the quality indicators in Compact SSR messages as defined in Sections 5.4.2. and 5.4.3., and the null message.

Integrity information can be commonly used in any application. Implementation of processing related to integrity information is not indispensable, but there are usage as follows.

The ranging error for satellite "i" can be estimated by the user receiver as follows:

$$\sigma_i = \sqrt{(\sigma_{i,user})^2 + (\sigma_{i,sis}/10)^2 + \left(\frac{40.3 \times 10^{16}}{f^2} \sigma_{i,iono} \times 100\right)^2 + ((\sigma_{i,trop}/10)/\sin E_i)^2}$$

Where, $\sigma_{i,user}$ is local error such as multipath in [cm], $\sigma_{i,sis}$ is SIS (Signal In Space) error such as orbit, clock and signal bias of satellite provided by the Compact SSR GNSS URA message in [mm], $\sigma_{i,iono}$ is ionospheric delay estimation error provided by the Compact SSR STEC Correction message in [TECU], $\sigma_{i,trop}$ is troposphere delay estimation error provided by the Compact SSR Gridded Correction message in [mm]. E_i is the satellite elevation angle in [rad]. The first term $\sigma_{i,user}$ should be defined in the user receiver, the other term is provided by CLAS.

If the estimated ranging error exceeds the user defined threshold for each application, user receivers can, for example, (a) discard the Compact SSR message, (b) decrease the weight of the corresponding satellite observation in the positioning process, or (c) avoid fixing the corresponding satellite carrier phase ambiguities in the positioning process.

Document subject to the disclaimer of liability

5.4.1. Alert Flag

The 1-bit Alert flag that follows the message type ID in each message indicates the comprehensive health status for the satellite system, ground system, and external systems configured in CLAS.

When the Alert flag is set to “1”_(B), this indicates a situation in which CLAS should not be used. In this case, the L6 signal should be used at the user’s own risk.

5.4.2. SSR URA

The SSR user range accuracy (URA) (1 sigma) indicates the quality indicator of SSR correction information for a signal in space (SIS). The user converts the 6-bit index information represented by a combination CLASS and VALUE included in the compact SSR GNSS URA message to a physical quantity using the following equation. The relationship between the SSR URA and index is presented in Table 5.4.2-1. A detailed definition of this message is given in Section 3.5.12.10 of the applicable document (2).

$$\text{SSR URA [mm]} \leq 3^{\text{CLASS}} \left(1 + \frac{\text{VALUE}}{4}\right) - 1 \text{ [mm]}$$

Table 5.4.2-1 Relationship between SSR URA or SSR troposphere quality indicator and physical quantity

Class	Value	Index	SSR URA and SSR Troposphere Quality Indicator [mm]
7	7	63	5466.50 < SSR URA
7	6	62	4919.75 < SSR URA ≤ 5466.50
7	5	61	4373.00 < SSR URA ≤ 4919.75
7	4	60	3826.25 < SSR URA ≤ 4373.00
7	3	59	3279.50 < SSR URA ≤ 3826.25
7	2	58	2732.75 < SSR URA ≤ 3279.50
7	1	57	2186.00 < SSR URA ≤ 2732.75
7	0	56	2003.75 < SSR URA ≤ 2186.00
6	7	55	1821.50 < SSR URA ≤ 2003.75
6	6	54	1639.25 < SSR URA ≤ 1821.50
6	5	53	1457.00 < SSR URA ≤ 1639.25
6	4	52	1274.75 < SSR URA ≤ 1457.00
6	3	51	1092.50 < SSR URA ≤ 1274.75
6	2	50	910.25 < SSR URA ≤ 1092.50
6	1	49	728.00 < SSR URA ≤ 910.25
6	0	48	667.25 < SSR URA ≤ 728.00
5	7	47	606.50 < SSR URA ≤ 667.25
5	6	46	545.75 < SSR URA ≤ 606.50
5	5	45	485.00 < SSR URA ≤ 545.75
5	4	44	424.25 < SSR URA ≤ 485.00

(Table continues)

(Table continued)

Class	Value	Index	SSR URA and SSR Troposphere Quality Indicator [mm]
5	3	43	363.50 < SSR URA ≤ 424.25
5	2	42	302.75 < SSR URA ≤ 363.50
5	1	41	242.00 < SSR URA ≤ 302.75
5	0	40	221.75 < SSR URA ≤ 242.00
4	7	39	201.50 < SSR URA ≤ 221.75
4	6	38	181.25 < SSR URA ≤ 201.50
4	5	37	161.00 < SSR URA ≤ 181.25
4	4	36	140.75 < SSR URA ≤ 161.00
4	3	35	120.50 < SSR URA ≤ 140.75
4	2	34	100.25 < SSR URA ≤ 120.50
4	1	33	80.00 < SSR URA ≤ 100.25
4	0	32	73.25 < SSR URA ≤ 80.00
3	7	31	66.50 < SSR URA ≤ 73.25
3	6	30	59.75 < SSR URA ≤ 66.50
3	5	29	53.00 < SSR URA ≤ 59.75
3	4	28	46.25 < SSR URA ≤ 53.00
3	3	27	39.50 < SSR URA ≤ 46.25
3	2	26	32.75 < SSR URA ≤ 39.50
3	1	25	26.00 < SSR URA ≤ 32.75
3	0	24	23.75 < SSR URA ≤ 26.00
2	7	23	21.50 < SSR URA ≤ 23.75
2	6	22	19.25 < SSR URA ≤ 21.50
2	5	21	17.00 < SSR URA ≤ 19.25
2	4	20	14.75 < SSR URA ≤ 17.00
2	3	19	12.50 < SSR URA ≤ 14.75
2	2	18	10.25 < SSR URA ≤ 12.50
2	1	17	8.00 < SSR URA ≤ 10.25
2	0	16	7.25 < SSR URA ≤ 8.00

(Table continues)

(Table continued)

Class	Value	Index	SSR URA and SSR Troposphere Quality Indicator [mm]
1	7	15	6.50 < SSR URA ≤ 7.25
1	6	14	5.75 < SSR URA ≤ 6.50
1	5	13	5.00 < SSR URA ≤ 5.75
1	4	12	4.25 < SSR URA ≤ 5.00
1	3	11	3.50 < SSR URA ≤ 4.25
1	2	10	2.75 < SSR URA ≤ 3.50
1	1	9	2.00 < SSR URA ≤ 2.75
1	0	8	1.75 < SSR URA ≤ 2.00
0	7	7	1.50 < SSR URA ≤ 1.75
0	6	6	1.25 < SSR URA ≤ 1.50
0	5	5	1.00 < SSR URA ≤ 1.25
0	4	4	0.75 < SSR URA ≤ 1.00
0	3	3	0.50 < SSR URA ≤ 0.75
0	2	2	0.25 < SSR URA ≤ 0.50
0	1	1	SSR URA ≤ 0.25
0	0	0	SSR URA undefined/unknown

5.4.3. Atmosphere Correction Quality Indicator

The atmosphere correction quality indicator is composed of the SSR STEC quality indicator and SSR troposphere quality indicator. Table 5.4.3-1 describes the relationship between the SSR STEC quality indicator and the physical quantity. The relationship between the SSR troposphere quality indicator and index is the same as the SSR URA, as presented in Table 5.4.2-1.

Table 5.4.3-1 Relationship between SSR STEC quality indicator and physical quantity

Class	Value	Index	SSR STEC Quality Indicator [TECU]
7	7	63	33.6664 < Indicator
7	6	62	30.2992 < Indicator ≤ 33.6664
7	5	61	26.9319 < Indicator ≤ 30.2992
7	4	60	23.5647 < Indicator ≤ 26.9319
7	3	59	20.1974 < Indicator ≤ 23.5647
7	2	58	16.8301 < Indicator ≤ 20.1974
7	1	57	13.4629 < Indicator ≤ 16.8301
7	0	56	12.3405 < Indicator ≤ 13.4629
6	7	55	11.2180 < Indicator ≤ 12.3405
6	6	54	10.0956 < Indicator ≤ 11.2180
6	5	53	8.9732 < Indicator ≤ 10.0956
6	4	52	7.8508 < Indicator ≤ 8.9732
6	3	51	6.7284 < Indicator ≤ 7.8508
6	2	50	5.6059 < Indicator ≤ 6.7284
6	1	49	4.4835 < Indicator ≤ 5.6059
6	0	48	4.1094 < Indicator ≤ 4.4835
5	7	47	3.7352 < Indicator ≤ 4.1094
5	6	46	3.3611 < Indicator ≤ 3.7352
5	5	45	2.9870 < Indicator ≤ 3.3611
5	4	44	2.6128 < Indicator ≤ 2.9870
5	3	43	2.2387 < Indicator ≤ 2.6128
5	2	42	1.8645 < Indicator ≤ 2.2387
5	1	41	1.4904 < Indicator ≤ 1.8645
5	0	40	1.3657 < Indicator ≤ 1.4904
4	7	39	1.2410 < Indicator ≤ 1.3657
4	6	38	1.1163 < Indicator ≤ 1.2410
4	5	37	0.9915 < Indicator ≤ 1.1163
4	4	36	0.8668 < Indicator ≤ 0.9915
4	3	35	0.7421 < Indicator ≤ 0.8668
4	2	34	0.6174 < Indicator ≤ 0.7421
4	1	33	0.4927 < Indicator ≤ 0.6174
4	0	32	0.4511 < Indicator ≤ 0.4927

(Table continues)

(Table continued)

Class	Value	Index	SSR STEC Quality Indicator [TECU]
3	7	31	0.4096 < Indicator \cong 0.4511
3	6	30	0.3680 < Indicator \cong 0.4096
3	5	29	0.3264 < Indicator \cong 0.3680
3	4	28	0.2848 < Indicator \cong 0.3264
3	3	27	0.2433 < Indicator \cong 0.2848
3	2	26	0.2017 < Indicator \cong 0.2433
3	1	25	0.1601 < Indicator \cong 0.2017
3	0	24	0.1463 < Indicator \cong 0.1601
2	7	23	0.1324 < Indicator \cong 0.1463
2	6	22	0.1186 < Indicator \cong 0.1324
2	5	21	0.1047 < Indicator \cong 0.1186
2	4	20	0.0908 < Indicator \cong 0.1047
2	3	19	0.0770 < Indicator \cong 0.0908
2	2	18	0.0631 < Indicator \cong 0.0770
2	1	17	0.0493 < Indicator \cong 0.0631
2	0	16	0.0447 < Indicator \cong 0.0493
1	7	15	0.0400 < Indicator \cong 0.0447
1	6	14	0.0354 < Indicator \cong 0.0400
1	5	13	0.0308 < Indicator \cong 0.0354
1	4	12	0.0262 < Indicator \cong 0.0308
1	3	11	0.0216 < Indicator \cong 0.0262
1	2	10	0.0169 < Indicator \cong 0.0216
1	1	9	0.0123 < Indicator \cong 0.0169
1	0	8	0.0108 < Indicator \cong 0.0123
0	7	7	0.0092 < Indicator \cong 0.0108
0	6	6	0.0077 < Indicator \cong 0.0092
0	5	5	0.0062 < Indicator \cong 0.0077
0	4	4	0.0046 < Indicator \cong 0.0062
0	3	3	0.0031 < Indicator \cong 0.0046
0	2	2	0.0015 < Indicator \cong 0.0031
0	1	1	Indicator \cong 0.0015
0	0	0	Indicator undefined/unknown

5.4.4. Null Message

The null message indicates those situations in which CLAS should not be used.

5.5. Calculation Algorithms for Compact SSR

This section shows the compact SSR calculation algorithms, which are also defined in the applicable document (3). Also the observation space representation (OSR) calculation algorithm from the Compact SSR is shown in the section 5.5.6.

5.5.1. Calculation of GNSS Clock Correction

5.5.1.1 Parameter

Table 5.5.1-1 and Table 5.5.1-2 show the parameters defined in the Compact SSR GNSS Clock Correction message and Compact SSR GNSS Combined message. Table 5.5.1-3 lists the parameter required for the calculations.

The algorithms are same for GPS, QZSS (Block IIQ and Block IIG), Galileo, and GLONASS (CDMA).

Table 5.5.1-1 Compact SSR GNSS Clock Correction message parameter

Parameter	Definition	Unit
C_0	Compact SSR Delta Clock	m

Table 5.5.1-2 Compact SSR GNSS Combined message parameter

Parameter	Definition	Unit
$C_{0,k}$	Compact SSR Delta Clock for a specific network k	m

Table 5.5.1-3 Other parameter

Parameter	Definition	Unit
c	Speed of Light (Section 5.3.1.)	m/s

5.5.1.2 Algorithm

If “Network correction” and “Clock Existing Flag” in the sub type 11 message is equals to “1”, the sub type 11 message includes “Compact SSR Delta Clock” in a specific network. The network is identified by “Network ID”. The clock in the network k for satellite PRN is respectively defined by,

```

if “Network correction” == 1 and “Clock Existing Flag”==1 in a specific network
     $C'_{0,k} = C_{0,k}$ 
else
     $C'_{0,k} = C_0$ 
end
    
```

Satellite clock correction δC establishes the following relationship between the parameters of the compact SSR GNSS clock correction.

$$\delta C = C'_{0,k}$$

Where the relationship between the SV clock $t_{broadcast}$ which is derived from the SV clock parameter of the navigation message and satellite clock, derived from the compact SSR GNSS clock correction and SV clock $t_{satellite}$ after correction are as follows:

$$t_{satellite} = t_{broadcast} - \frac{\delta C}{C}$$

5.5.2. Calculation of GNSS Orbit Correction

5.5.2.1 Parameters

Table 5.5.2-1 and Table 5.5.2-2 list the parameters defined in the Compact SSR GNSS Orbit Correction message and Compact SSR GNSS Combined message. Table 5.5.2-3 lists the other parameters required for the calculations.

The algorithms are same for GPS, QZSS (Block IIQ and Block IIG), Galileo, and GLONASS (CDMA).

Table 5.5.2-1 Compact SSR GNSS Orbit Correction message parameters

Parameter	Definition	Unit
δO_{radial}	Compact SSR Delta Radial	m
δO_{along}	Compact SSR Delta Along Track	m
δO_{cross}	Compact SSR Delta Cross Track	m

Table 5.5.2-2 Compact SSR GNSS Combined message parameters

Parameter	Definition	Unit
$\delta O_{radial,k}$	Compact SSR Delta Radial for a specific network k	m
$\delta O_{along,k}$	Compact SSR Delta Along Track for a specific network k	m
$\delta O_{cross,k}$	Compact SSR Delta Cross Track for a specific network k	m

Table 5.5.2-3 Other parameters

Parameter	Definition	Unit
δX	Satellite Orbit Correction	m
e_{radial}	Delta Radial Unit Vector	-
e_{along}	Delta Along Track Unit Vector	-
e_{cross}	Delta Cross Track Unit Vector	-
r	Satellite Position calculated from broadcast ephemeris	m
\dot{r}	Satellite Speed calculated from broadcast ephemeris	m/s

5.5.2.2 Algorithm

If “Network correction” and “Orbit Existing Flag” in the sub type 11 message is equals to “1”, the sub type 11 message includes “Compact SSR Delta Radial/Along-Track/Cross-Track” in a specific network. The network is identified by “Network ID”. The orbit in the network k for satellite PRN is respectively defined by,

if “Network correction” = 1 and “Orbit Existing Flag”=1 in a specific network

$$\delta O'_{radial,k} = \delta O_{radial,k}$$

$$\delta O'_{along,k} = \delta O_{along,k}$$

$$\delta O'_{cross,k} = \delta O_{cross,k}$$

else

$$\delta O'_{radial,k} = \delta O_{radial}$$

$$\delta O'_{along,k} = \delta O_{along}$$

$$\delta O'_{cross,k} = \delta O_{cross}$$

end

Satellite orbit correction $\delta \mathbf{X}$ at time t is calculated as follows:

$$\delta \mathbf{X} = [\mathbf{e}_{radial} \quad \mathbf{e}_{along} \quad \mathbf{e}_{cross}] \begin{bmatrix} \delta O'_{radial,k} \\ \delta O'_{along,k} \\ \delta O'_{cross,k} \end{bmatrix}$$

where

$$\mathbf{e}_{along} = \frac{\dot{\mathbf{r}}(t)}{|\dot{\mathbf{r}}(t)|}, \mathbf{e}_{cross} = \frac{\mathbf{r}(t) \times \dot{\mathbf{r}}(t)}{|\mathbf{r}(t) \times \dot{\mathbf{r}}(t)|}, \mathbf{e}_{radial} = \mathbf{e}_{along}(t) \times \mathbf{e}_{cross}(t)$$

The relationship among the satellite position \mathbf{r} derived from the broadcast ephemeris, the satellite orbit correction $\delta \mathbf{X}$ derived from the compact SSR GNSS orbit correction message, and the corrected satellite position \mathbf{X}_{orbit} are as follows:

$$\mathbf{X}_{orbit} = \mathbf{r} - \delta \mathbf{X}$$

Note that the satellite broadcast velocity vector $\dot{\mathbf{r}}$ for the GEO satellite (QZS-3) can be null, which gives no satellite orbit corrections using the above equations. The velocity vector for QZS-3 is therefore defined in a non-rotating system parallel to the IGS05 at QZSST epoch time as follows:

$$\dot{\mathbf{r}} = \dot{\mathbf{r}}_{broadcast} + \begin{bmatrix} -\dot{\Omega}_e Y_{broadcast} \\ \dot{\Omega}_e X_{broadcast} \\ 0 \end{bmatrix}$$

where the value of the angular velocity of the Earth’s rotation $\dot{\Omega}_e$ is defined in the section 5.3.3.

Document subject to the disclaimer of liability

5.5.3. Calculation of GNSS Code/Phase Bias

5.5.3.1 Parameter

Table 5.5.3-1 and Table 5.5.3-2 shows the parameter defined in the sub type 4 (compact SSR GNSS Satellite Code Bias) message and sub type 5 (compact SSR GNSS Satellite Phase Bias) message and the sub type 6 (Compact SSR GNSS Satellite Code and Phase Bias) message.

The algorithms are same for GPS, QZSS (Block IIQ and Block IIG), Galileo, and GLONASS (CDMA).

Table 5.5.3-1 Compact SSR GNSS Satellite Code Bias message parameter and Phase Bias message parameter

Parameter	Definition	Unit
$BIAS_{phase\ or\ code}^{PRN}$ *	Compact SSR Code Bias (sub type 4) or Compact SSR Phase Bias (sub type 5)	m

* If sub type 4 or sub type 5 are not included in a frame, it is set to zero.

Table 5.5.3-2 Compact SSR GNSS Satellite Code and Phase Bias message parameter

Parameter	Definition	Unit
$\delta BIAS_{k,phase\ or\ code}^{PRN}$	Compact SSR Code Bias(sub type 6) or Compact SSR Phase Bias(sub type 6)	m
los_{user}^{PRN}	Line-of-sight vector from user's rough position to the satellite in earth center earth fixed coordinates	-

5.5.3.2 Algorithm

If “Network Bias correction” in the sub type 6 message is equals to “1”, the sub type 6 message includes bias phase and/or code bias correction in a specific network. The network is identified by “Network ID”. The code or phase bias in the network k for satellite PRN is respectively defined by,

$$NET_BIAS_{k,phase\ or\ code}^{PRN} = BIAS_{phase\ or\ code}^{PRN} + \delta BIAS_{k,phase\ or\ code}^{PRN}$$

Note that update timing of $\delta BIAS_{k,phase}^{PRN}$ included in sub type 6 is different from the Compact SSR orbit correction message (sub type 2) in CLAS. This may cause discontinuity in corrected measurement when latest orbit correction message is applied while previous $\delta BIAS_{k,phase}^{PRN}$ is still used. The discontinuity can be compensated by subtracting difference of sum of clock and orbit correction between before (i-1th) and after (ith) the update of the orbit correction as follows:

$$\delta BIAS_{k,phase}^{PRN'} = \delta BIAS_{k,phase}^{PRN} - [\{-\delta C_i^{PRN} - \delta X_i^{PRN} \cdot \mathbf{los}_{user}^{PRN}(t)\} - \{-\delta C_{i-1}^{PRN} - \delta X_{i-1}^{PRN} \cdot \mathbf{los}_{user}^{PRN}(t-1)\}]$$

where t is the update epoch of the latest Compact SSR GNSS orbit correction message.

5.5.4. Calculation of Ionosphere Slant Delay Correction

5.5.4.1 Parameters

Table 5.5.4-1 lists the parameters defined in the compact SSR STEC network correction, compact SSR gridded correction and Atmospheric correction.

Table 5.5.4-2 lists the parameters required for the calculations.

The algorithms are same for GPS, QZSS (Block IIQ and Block IIG), Galileo, and GLONASS (CDMA).

Table 5.5.4-1 Compact SSR STEC network correction, compact SSR gridded correction, and compact SSR Atmospheric correction message parameters

Parameter	Definition	Unit
STEC Polynomial Coefficients $C_{00}, C_{01}, C_{10}, C_{11}, C_{02}, C_{20}$	SSR ionosphere slant delay correction : Polynomial Coefficients	TECU
STEC Residual Correction $\delta STEC$	SSR ionosphere slant delay correction : Grid-specific parameter	TECU

Table 5.5.4-2 Other parameters

Parameter	Definition	Unit
f	Frequency	Hz

5.5.4.2 Algorithm

The ionosphere slant delay (STEC) consists of the polynomial part of the compact SSR STEC network correction message and the residual part from the compact SSR gridded correction message.

At first, 4 or 3 reference grids with valid STEC values from the compact SSR gridded correction message surrounding the user's rough position obtained from the likes of single-point positioning are selected.

Then, the ionosphere slant delay I_k^{PRN} at each reference grid k and time t for the pseudo-range of satellite PRN is calculated as follows:

$$I_{k,pseudorange}^{PRN}(t) = \frac{40.31 * 10^{16}}{f^2} \times STEC_k^{PRN}(t)$$

where,

$STEC_k^{PRN}(t)$ is calculated in accordance with the "STEC Correction Type" included in the compact SSR STEC correction message, as follows:

STEC Correction Type = 0:

$$STEC_k^{PRN}(t) = C_{00}^{PRN}(t) + \delta STEC_k^{PRN}(t)$$

STEC Correction Type = 1:

$$STEC_k^{PRN}(t) = C_{00}^{PRN}(t) + C_{01}^{PRN}(t)(\varphi - \varphi_0) + C_{10}^{PRN}(t)(\lambda - \lambda_0) + \delta STEC_k^{PRN}(t)$$

STEC Correction Type = 2:

$$STEC_k^{PRN}(t) = C_{00}^{PRN}(t) + C_{01}^{PRN}(t)(\varphi - \varphi_0) + C_{10}^{PRN}(t)(\lambda - \lambda_0) + C_{11}^{PRN}(t)(\varphi - \varphi_0)(\lambda - \lambda_0) + \delta STEC_k^{PRN}(t)$$

STEC Correction Type = 3:

$$STEC_k^{PRN}(t) = C_{00}^{PRN}(t) + C_{01}^{PRN}(t)(\varphi - \varphi_0) + C_{10}^{PRN}(t)(\lambda - \lambda_0) + C_{11}^{PRN}(t)(\varphi - \varphi_0)(\lambda - \lambda_0) + C_{02}^{PRN}(t)(\varphi - \varphi_0)^2 + C_{20}^{PRN}(t)(\lambda - \lambda_0)^2 + \delta STEC_k^{PRN}(t)$$

with

φ, λ : Grid coordinate (Latitude, Longitude)

φ_0, λ_0 : Grid coordinate of the smallest Grid ID within each network (Latitude, Longitude) for which the coordinates are as defined in Section 4.1.4

Note: If STEC Network Correction is not defined at a specific network, it should be defined as zero.

Last, the ionosphere slant delay for the satellite PRN at the user position $I_{user}^{PRN}(t)$ is computed by interpolating or extrapolating $I_k^{PRN}(t)$ on reference grids. An example interpolation method is the bilinear method defined in the data filed DF212 of the applicable document (2). The following equation is to be utilized for interpolation with four nearest grids. The weighting coefficient W_k for each grid is computed depending on the distance between user's rough position and the grid position.

$$I_{user}^{PRN}(t) = \sum_{k=1}^4 W_k I_k^{PRN}(t)$$

For interpolation or extrapolation with three grids, a similar algorithm is used. The weighting coefficient w_k for each grid is computed depending on the distance between user's rough position and the grid position.

$$I_{user}^{PRN}(t) = \sum_{k=1}^3 w_k I_k^{PRN}(t)$$

Note: For carrier-phase range correction, the opposite sign should be applied.

$$I_{k,carrier\ phase}^{PRN}(t) = -\frac{40.31 * 10^{16}}{f^2} \times STEC_k^{PRN}(t)$$

5.5.5. Calculation of Troposphere Delay Correction

5.5.5.1 Parameters

Table 5.5.5-1 lists the parameters defined in the compact SSR gridded correction message. Table 5.5.5-2 lists the parameters required for calculations and recalculations.

The algorithms are same for GPS, QZSS (Block IIQ and Block IIG), Galileo, and GLONASS (CDMA).

Table 5.5.5-1 Compact SSR Gridded Correction Message Parameters

Parameter	Definition	Unit
$\Delta T_{k,hs}$	Troposphere Hydrostatic Vertical Delay Variation at GRID k	m
$\Delta T_{k,wet}$	Troposphere Wet Vertical Delay Variation at GRID k	m

Table 5.5.5-2 Parameters

Parameter	Definition	Unit
M_{hs}^{PRN}	Mapping Function (Hydrostatic)	-
M_{wet}^{PRN}	Mapping Function (Wet)	-
δ_{hs0}	Troposphere Vertical Delay Hydrostatic Variation constant value(= 2.3)	m
δ_{wet0}	Troposphere Vertical Delay Wet Variation constant value sub type 9: 0.252 sub type 12: Troposphere residual offset	m
el	Elevation Angle	deg

5.5.5.2 Algorithm

At first, 4 or 3 reference grids with a valid troposphere vertical delay surrounding the user's rough position are selected. The rough position is obtained from the likes of single-point positioning.

The hydrostatic vertical delay $T_{k,hs}(t)$ and wet vertical delay $T_{k,wet}(t)$ at time t at a selected GRID k are computed by using the troposphere hydrostatic vertical delay variation $\Delta T_{k,hs}(t)$ and wet vertical delay variation $\Delta T_{k,wet}(t)$ in the compact SSR gridded correction message.

$$T_{k,hs}(t) = \Delta T_{k,hs}(t) + \delta_{hs0}$$

$$T_{k,wet}(t) = \Delta T_{k,wet}(t) + \delta_{wet0}$$

$T_{user,hs}(t)$ and $T_{user,wet}(t)$ are computed by interpolating or extrapolating the data on the reference grid. An example interpolation or extrapolation method is the bi-linear method defined in the data filed DF212 of the applicable document (2). The following equation is to be utilized for interpolation with four nearest grids. The weighting coefficient W_k for each grid is computed depending on the distance between user's rough position and the grid position.

$$T_{user,hs}(t) = \sum_{k=1}^4 W_k T_{k,hs}(t)$$

$$T_{user,wet}(t) = \sum_{k=1}^4 W_k T_{k,wet}(t)$$

For interpolation or extrapolation with three grids, a similar algorithm is used. The weighting coefficient w_k for each grid is computed depending on the distance between user's rough position and the grid position.

$$T_{user,hs}(t) = \sum_{k=1}^3 w_k T_{k,hs}(t)$$

$$T_{user,wet}(t) = \sum_{k=1}^3 w_k T_{k,wet}(t)$$

Last, the troposphere slant delay $T_{user}^{PRN}(t)$ is computed by using Niell mapping function $M_{user,hs}^{PRN}(el, t)$ and $M_{user,wet}^{PRN}(el, t)$ at the user's rough position as described in the reference document (4).

$$T_{user}^{PRN}(t) = T_{user,hs}(t) \cdot M_{user,hs}^{PRN}(el, t) + T_{user,wet}(t) \cdot M_{user,wet}^{PRN}(el, t)$$

5.5.6. (Reference) User dependent errors

The estimated compact SSR parameters of CLAS are free of reference station site displacements, phase wind up effect, receiver antenna PCV, inter system bias, quarter cycle shifts and etc. Users have to apply corresponding user dependent corrections when using compact SSR parameters in the positioning calculation process.

The following correction models have to be considered to meet the CLAS positioning accuracy described in the Section 6.3 of the applicable document (1).

- solid earth tides
- ocean loading
- pole tide
- phase wind up
- receiver antenna phase center offset and variation (PCO, PCV)
- receiver inter system bias (ISB)
- receiver quarter cycle carrier phase shifts
(if provided carrier phase bias for different signals on the same frequency)

References for user site displacements such as solid earth tide, ocean loading and pole tide are the IERS Conventions (6) Section 7. References for phase wind-up correction is the reference document (5). Reference for the method of user receiver inter system bias estimation and its compensation at user receivers are Section 5-2 of the reference document (9).

Note that in the phase wind up computation, a satellite yaw angle² used for the computation is always zero. It is not necessary to use a satellite attitude model.

² The satellite yaw angle is defined as the rotation angle around the satellites radial axis and represents the angle between the satellites along-track vector and satellites X-axis in the satellites along-track, across-track plane counter positive clockwise.

5.5.7. (Reference) Calculation of Observation Space Representation

5.5.7.1 Parameters

Table 5.5.7-1 lists the parameters defined between in the Section 5.5.1 and in the Section 5.5.6, which are used for calculation of the carrier phase correction (CPC) and the pseudo range correction (PRC) from the compact SSR messages as examples of observation space representation (OSR). The carrier phase correction and the pseudo range correction are similar data defined in the message type 20 and 21 of RTCM 10402.3 Recommended Standards for Differential GNSS Service version 2.3.

Table 5.5.7-1 Parameters

Parameter	Definition	Unit
δC^{PRN}	Satellite clock correction	m
$\delta \mathbf{X}^{PRN}$	Satellite orbit correction	m
$\mathbf{los}_{user}^{PRN}$	Line-of-sight vector from user's rough position to the satellite in earth center earth fixed coordinates	-
$NET_BIAS_{k,phase\ or\ code}^{PRN}$	Satellite phase bias or code bias correction for the specific network k where the user's rough position is located	m
I_{user}^{PRN}	Ionosphere slant delay at the user's rough position	m
T_{user}^{PRN}	Troposphere slant delay at the user's rough position	m

5.5.7.2 Algorithm

Carrier phase correction CPC or pseudo range correction PRC at user's rough position at time t for satellite PRN is defined by,

$$CPC_{user}^{PRN}(t) = -\delta C^{PRN}(t) - \delta \mathbf{X}^{PRN} \cdot \mathbf{los}_{user}^{PRN}(t) + NET_BIAS_{k,phase}^{PRN}(t) - I_{user}^{PRN}(t) + T_{user}^{PRN}(t)$$

$$PRC_{user}^{PRN}(t) = -\delta C^{PRN}(t) - \delta \mathbf{X}^{PRN} \cdot \mathbf{los}_{user}^{PRN}(t) + NET_BIAS_{k,code}^{PRN}(t) + I_{user}^{PRN}(t) + T_{user}^{PRN}(t)$$

Here, if the satellite clock correction δC and the orbit correction δX have already applied to the broadcast ephemeris shown in the section 5.5.1 and 5.5.2, the above related term ($\delta C^{PRN}(t)$ and $\delta \mathbf{X}^{PRN} \cdot \mathbf{los}_{user}^{PRN}(t)$) are excluded from the formula.

And note that the user receiver side specific compensations such as user site displacements, phase wind up, user receiver antenna phase center offset (PCO), user receiver phase center variation (PCV), quarter cycle carrier phase shifts and user receiver inter system bias (ISB) which are described in the section 5.5.6, are excluded from this OSR calculation formula. Users have to apply these compensations to the GNSS observation data (both carrier phase and pseudo range) in the process of generating single or double difference observations between satellites required for the positioning calculation process.

To combine two patterns of L6D signals (see section 4.1.1.2 for details on the two patterns of L6D signals), when applying CPC or PRC with different Facilities to GNSS observation data of the same

epoch, users must form between-satellite differences for each Facilities in positioning calculation process. The Facility can be determined by the combination of “Message Generation Facility and CLAS Transmit Pattern ID” and “CLAS Transmit Pattern ID” (see section 4.1.2.1 for more information).