

Quasi-Zenith Satellite System
Interface Specification
Sub-meter Level Augmentation Service
(IS-QZSS-L1S-009)

(February 20, 2026)

Cabinet Office

Disclaimer of Liability

The Cabinet Office, Government of Japan (“CAO”) and Quasi-Zenith Satellite System Services Inc. make the User Interface Specification (IS-QZSS) (“Document”) available to the public to promote the services using Quasi-Zenith Satellite System (“QZSS”) by development of receivers, applications and so on, and also are aiming for high accuracy and convenience with respect to satellite positioning services and message services of QZSS (collectively “Services”). The Services are freely available to any user. However, the receivers and/or applications developed based on this Document may not receive signals or may receive incorrect signals due to no warranty of the Services. You are therefore highly recommended to ensure appropriate measures to avoid accidents such as redundancy, backup and fail-safe, if you develop receivers and/or applications using the Services for the purpose that will possibly give an impact to human life, body and properties. The Services may be suspended or changed without prior notice in accordance with the decision by Government of Japan. This Document and the Services are available subject to the following terms and conditions. You may use this Document only if you agree to such terms and conditions. You shall be deemed to agree such terms and conditions by using this Document.

(1) With respect to this Document and the information included in this Document, the Cabinet Office, Government of Japan (“CAO”) and Quasi-Zenith Satellite System Services Inc. (“QSS”) disclaim all warranties of any kind, express or implied, including but not limited to, the followings:

- i) warranty of accuracy, completeness, usefulness, and fitness for a particular request or purpose;
- ii) warranty that this Document and the information included in this Document will not be changed in to the future; and
- iii) warranty that this Document and the information included in this Document do not infringe any third party’s intellectual property rights.

(2) With respect to satellite positioning services and message services (collectively “Services”), CAO and QSS disclaim all warranties of any kind, express or implied, from any cause whether it is related to Quasi-Zenith Satellite System, other outside systems or not, including but not limited to, the followings:

- i) warranty as to service area, accuracy, availability, continuity, and integrity described in this Document;
- ii) warranty of usefulness, and fitness for a particular request or purpose; and
- iii) warranty that the use of Services does not infringe any third party’s intellectual property rights.

(3) To the extent permitted by applicable laws, CAO and QSS shall not be responsible and liable for any damages and losses, including but not limited to, direct, indirect, incidental, special or consequential damages, whether under contractual liability, product liability, strict liability, tort liability or otherwise (including intent or negligence), caused by the use of this Document, the information included in this Document and the Services, the inability to use the Services, or the change of this Document and the information included in this Document.

Document subject to the disclaimer of liability

Revision History

Rev. No.	Date	Page	Revisions
001 Draft Edition	January 10,2017	— — 22 27 30	Change from 001 Draft(2016/07/12)(Japanese) Separate related DC Report Service Delete Orbit and time Forecast (MT40,41) Table 4.1.2-9 (ID_5)Change Monitoring Station Gifu to Komatsu. (ID_63)Add not applicable value (N/A) to GMS_ID. Add coordinate value of each Monitoring Station Adds the correspondence between Message Type 48 and Message Type 49. Adds the correspondence between Message Type 48 and Message Type 50.
001	March 28,2017	—	First release
002	April 13,2018	14 20 38	Table 4.1.1 1 Correct Maximum Transmission Intervals (MT0,47). Table 4.1.2 3 Correct Effective range of GMS Hgt (MT47). Add subsection (5.5.3.3.).
003	November 5,2018	18,19	Adds DC Report message output from a receiver (MT43,44). Corrects description of Applicable Document.
004	November 26,2019	10	Table 3.2.1-1 (PRN186)Change Block Assignment Undetermined to Block IIA-Q.
005	February 3, 2023	14 23 26 27 32 34 35	Table 4.1.1-2 Corrects the table heading from “Update Interval” to “Nominal Update Interval”. Table 4.1.2-6 Deletes the first and last rows of the table. Figure 4.1.2-7 Corrects the number of “Satellite to be augmented” from 15 to 14. Separates Type 49 and Type 50 in the figure. Table 4.1.2-8 Corrects the description under of the table “~ and may not be ~” to “~and shall not be ~”. 5.2 Coordinate System Deletes the phrase of “used for PNT”. Adds the description of “This is the same coordinate system described in 5.2 of IS-QZSS-PNT.”. Corrects the word “IOD” to ”IODP and IODI” in the first sentence. Adds and modifies the description. Corrects the word “The user position (S)” to ”The user position (POS)”. Formula 5.5-4 Corrects the character of the variable “S” to “POS” Formula 5.5-5 Correct the elements in G matrix.

		36	Formula 5.5-9 Corrects the description of component " α_{multi} " to " σ_{multi} ". Corrects description of " $F_{pp, i}$ ".
		37	Formula 5.5-10 Corrects the component " $\sigma_{iono, i}^2$ " to " $\sigma_{iono, i}$ ".
		37	(4)Alert information (Message Type 51) Modifies the description.
		38	Formula 5.5-13 Corrects the component " ρ_n " to " $PR_n^{measured}$ ".
006	October 25, 2023	10	Table 3.2.1-1 Assignment of the PRN Number by Satellite categories Deletes the undetermined PRN codes.
		12	Table 3.2.1-2 LIS PRN Code phase assignment Deletes the undetermined PRN codes.
		39-41	Add subsection (5.5.3.4.).
007	April 18, 2024	2	Adds the applicable document (3) "IS-QZSS-DCX" (2.1).
		13	Corrects the description so that MT44 is not covered from SLAS messages in the text (4.1.1.2(1))
		14-16	Correct Message Data of MT44 to be "DCX message" in Table 4.1.1-1, 4.1.1-2, and 4.1.2-1.
		25	Correct the description so that the contents of MT44 is DCX message (4.1.2.5).
008	April 25, 2025	14	4.1.1.2. Timing (2) Transmission Interval Table 4.1.1-1 Maximum Transmission Intervals Add the conditions of MT43 and MT44.
009	February 20, 2026	21	4.1.2.6. Message Type 47: Monitoring Station Information Table 4.1.2 4 GMS ID Updated Lat, Lon, Hgt for GSM ID: 8 (Fukuoka) Lat : 33.60 → 33.67 (New latitude) Lon : 130.23 → 130.39 (New longitude) Hgt : 50 → 50 (No change)
		34	(2) Monitoring station location Add following sentence: For each GMS ID, the monitoring station location transmitted via MT47 shall take precedence over the one defined in this document. 5.5.2.(1) Correct the "second nearest monitoring station" to the "alternative monitoring station". Table 5.5-1 Add Table 5.5-1 (showing the combinations of each monitoring station and its alternative monitoring station).

In this the text "TBD" is an abbreviation for "To be determined" meaning that the item referred to is undetermined at present but will be determined in the future.

Table of Contents

1. Scope	1
2. Relevant Documents and Definition of Terms	2
2.1. Applicable Documents	2
2.2. Reference Documents	3
2.3. Abbreviations	4
3. Signal Specifications	6
3.1. RF Characteristics	6
3.1.1. Signal Structure	6
3.1.2. Frequency	6
3.1.3. Modulation Methods	7
3.1.3.1. L1S	7
3.1.4. Correlation Loss	7
3.1.5. Carrier Phase Noise	7
3.1.6. Spurious	7
3.1.7. Phase Relationship within Signals	8
3.1.7.1. L1	8
3.1.8. Minimum Signal Strength	8
3.1.9. Polarization Property	8
3.1.10. Group Delay Property	8
3.1.10.1. Group Delay Between Signals	8
3.1.10.2. Group Delay Between Signals of Same Frequency	8
3.1.11. PRN Code Jitter	9
3.1.12. Code Carrier Coherence	9
3.2. PRN Codes	10
3.2.1. PRN Number Assignment	10
3.2.2. L1S Codes	11
3.2.3. Non-Standard Codes	12
4. Message Specifications	13
4.1. L1S	13
4.1.1. Message Configuration	13
4.1.1.1. Overview	13
4.1.1.2. Timing	13
4.1.1.3. Cyclic Redundancy Check (CRC)	15
4.1.1.4. Forward Error Correction (FEC)	15
4.1.2. Message Contents	16
4.1.2.1. Overview	16
4.1.2.2. Common Section	16
4.1.2.3. Message Type 0: Test Mode	17
4.1.2.4. Message Type 43: DC Report (JMA Disaster Prevention Information)	18

4.1.2.5. Message Type 44: DC Report (Other Organization).....	19
4.1.2.6. Message Type 47: Monitoring Station Information.....	20
4.1.2.7. Message Type 48: PRN Mask	22
4.1.2.8. Message Type 49 : Data Issue Number	24
4.1.2.9. Message Type 50: DGPS Correction	27
4.1.2.10. Message Type 51: Satellite Health	29
4.1.2.11. Message Type 63: Null Message	31
5. User Algorithm	32
5.1. Time System	32
5.2. Coordinate System	32
5.3. Constants	33
5.4. Health and Alert Flag.....	33
5.5. Procedure for Applying Correction Information	33
5.5.1. Selection of the SLAS messages transmitted satellite	33
5.5.2. Augmentation Using DGPS Correction.....	34
5.5.3. Accuracy.....	39
5.5.3.1. Smoothing	39
5.5.3.2. Quality Monitoring	39
5.5.3.3. Differential ISB Correction	40
5.5.3.4. Differential Tropospheric Delay Correction.....	40

1. Scope

This document describes the interface specifications of the sub-meter level augmentation service (SLAS) between the space segment of QZSS and the user segment. The interface specifications described herein include the signal characteristics, message specifications and user algorithms.

The content of system, service, accuracy, availability, continuity, integrity, and other user performance characteristics are described in the applicable document (1)PS-QZSS Quasi-Zenith Satellite System Performance Standard.

2. Relevant Documents and Definition of Terms

2.1. Applicable Documents

The following documents constitute part of this document within the scope defined in this document.

- (1) PS-QZSS Quasi-Zenith Satellite System Performance Standard
- (2) Quasi-Zenith Satellite System Interface Specification DC Report Service (IS-QZSS-DCR)
- (3) Quasi-Zenith Satellite System Interface Specification DCX Service (IS-QZSS-DCX)

2.2. Reference Documents

The reference document are as follows.

- (1) Quasi-Zenith Satellite System Interface Specification Satellite Positioning, Navigation and Timing Service (IS-QZSS-PNT)
- (2) Global Positioning Systems Directorate Systems Engineering & Integration Interface Specification IS-GPS-200, Navstar GPS Space Segment/Navigation User Interfaces, Revision H, 24-SEP-2013

2.3. Abbreviations

-A-

-B-

bps	bits per second
BPSK	Binary phase-shift keying

-C-

CPS	Chips per Second
CRC	Cyclic Redundancy Check

-D-

-E-

ECEF	Earth Center Earth Fixed
ECI	Earth Centerd Inertial
EOP	Earth Orientation Parameters

-F-

FEC	Forward Error Correction
-----	--------------------------

-G-

GEO	Geostationary Orbits
GPS	Global Positioning System
GPST	GPS Time

-H-

-I-

IERS	International Earth Rotation and Reference Systems Service
IODE	Issue of Data Ephemeris
IODP	Issue of Data PRN Mask

-J-

-K-

-L-

LSB	Least Significant Bit
-----	-----------------------

-M-

MSB	Most Significant Bit
-----	----------------------

-N-

-O-

-P-

PLL	Phase Locked Loop
PRN	Pseudorandom Noise

-Q-

QZO	Quasi-Zenith Orbits
QZS	Quasi-Zenith Satellite
QZSS	Quasi-Zenith Satellite System

-R-

RF	Radio Frequency
----	-----------------

	RMS	Root Mean Square
-S-		
	SIS	Signal-In-Space
	SIS-URE	Signal-In-Space User Range Error
	sps	symbols per second
	SV	Satellite Vehicle
-T-		
	TAI	Time of Interval
	TTA	Time-To-Alert
-U-		
	URA	User Range Accuracy
	UT1	Universal Time1
	UTC	Coordinated Universal Time
-V-		
-W-		
-X-		
-Y-		
-Z-		

3. Signal Specifications

3.1. RF Characteristics

3.1.1. Signal Structure

The signal structure, PRN code characteristic and message characteristics are as shown in Table 3.1.1-1, Table 3.1.1-2 and Table 3.1.1-3.

Table 3.1.1-1 Signal Structure

Frequency Band	Signal Name	Modulation Method	PRN Code Name	Overlay Code Name	Message Name
L1	L1S	BPSK	L1S	-	L1S

Table 3.1.1-2 PRN Code Characteristics

PRN Code Name	Chip Rate	Length	Period	Overlay Code
L1S	1.023 Mcps	1023 chips	1 millisecond	-

Table 3.1.1-3 Message Characteristics

Message Name	Bit Rate	Symbol Rate	Period (Minimum Frame)	Encoding Method
L1S	250 bps	500 sps	1 second	CRC convolutional code

3.1.2. Frequency

The frequency band, nominal center frequency and occupied bandwidth of L1S signals are shown in Table 3.1.2-1.

However, the reference frequency (f_0) = 10.23 MHz is offset by the nominal $\Delta f/f_0 = -5.399E-10$ to compensate for the frequency difference between the ground surface and satellite orbit due to the relativistic effect. For this reason, the center frequency in the satellite orbit is not exactly precise. For example, the L1 band signal is offset by -0.8506 Hz (nominal).

Table 3.1.2-1 Center Frequency and Occupied Bandwidth

Frequency Band (Signal Name)	Nominal center frequency	Block I	Block II
L1 band (L1S)	1575.42 MHz	24.0 MHz (±12.0 MHz)	30.69 MHz (±15.345 MHz)

3.1.3. Modulation Methods

3.1.3.1. L1S

L1S signals are modulated by BPSK. The modulation method is shown in Figure 3.1.3-1.

L1S navigation messages and PRN codes are modulated by exclusive-OR (modulo 2 addition) and then modulated with L1 carrier waves by BPSK.

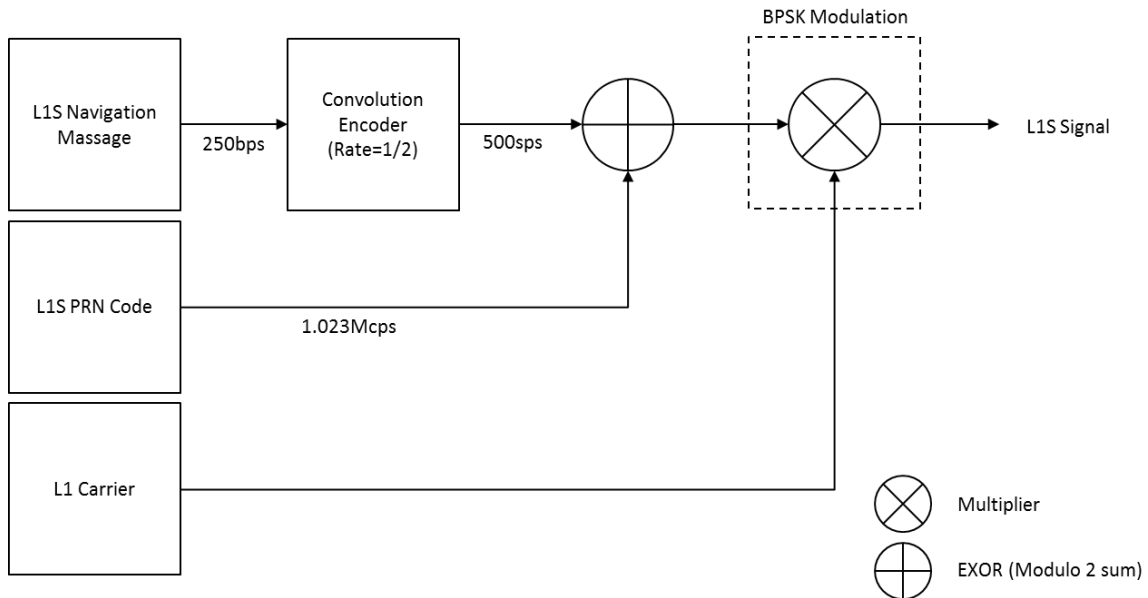

Figure 3.1.3-1 L1S Modulation

3.1.4. Correlation Loss

Correlation loss is defined as the energy ratio of carrier wave to output signals obtained by theoretically modulating the output signals by reverse diffusion.

The correlation loss values are as shown below:

- Block I: 0.6 dB or less
- Block II: 0.6 dB or less

3.1.5. Carrier Phase Noise

For L1S signals, the spectral density of the phase noise of the unmodulated carrier wave before superposition of the PRN code and navigation message, shall be such that a phase-locked loop (PLL) with single-sided bandwidth of 10Hz will be able to track the carrier phase to the following values:

- Block I: 0.1 rad (RMS)
- Block II: 0.1 rad (RMS)

3.1.6. Spurious

For L1S signals, the spurious transmission of the unmodulated carrier wave before superposition

Document subject to the disclaimer of liability

of the PRN code and navigation message, shall be as follows:

- Block I -40 dB or less
- Block II: -40 dB or less

3.1.7. Phase Relationship within Signals

3.1.7.1. L1

No specifications are defined for the L1S phase relationship between L1 signals.

3.1.8. Minimum Signal Strength

The minimum received power is measured at a ground-based isotropic antenna with a gain of 0dBi for circularly polarized wave reception, when L1S signals are received from a satellite with an elevation angle of 10° or more. The power is shown in Table 3.1.8-1.

Table 3.1.8-1 Minimum received power

Signal Name	Block I	Block II
L1S	-161.0 dBW	-158.5 dBW

3.1.9. Polarization Property

L1S signals are right-hand circularly polarized.

At the center frequency of each signal, the axial ratio (power ratio of the long axis to short axis) of the ellipse of the circularly polarized wave is within the beam range $\pm 10^\circ$ from the boresight direction and is shown in Table 3.1.9-1.

Table 3.1.9-1 Axis Ratio of the ellipse of the Circularly Polarized Wave

Signal Name	Block I	Block II
L1S	2.0 dB or less	2.0 dB or less

3.1.10. Group Delay Property

3.1.10.1. Group Delay Between Signals

L1S signals have no specification of group delay between signals.

3.1.10.2. Group Delay Between Signals of Same Frequency

L1S signals have no specification of group delay between signals of same frequency.

3.1.11. PRN Code Jitter

The jitter with the PRN code zero-crossing interval shall be as follows:

2.0 ns or less (3σ)

For PRN codes, the average time difference between the rising edge and the falling edge shall be as follows:

1.0 ns or less

3.1.12. Code Carrier Coherence

(1) Short-term code carrier coherence

The short-term (less than 10 seconds) difference between the code pseudorange rate and the Doppler frequency shall be less than 0.015 m/second (1σ).

(2) Long-term code carrier coherence

The long-term (less than 100 seconds) difference between the code pseudorange and the carrier phase pseudorange shall be less than 0.19 m (1σ).

3.2. PRN Codes

3.2.1. PRN Number Assignment

The assignment of the PRN numbers by satellite categories are shown in Table 3.2.1-1.

Table 3.2.1-1 Assignment of the PRN Number by Satellite categories

PRN	Satellite Type	Block Assignment	Remarks
183	QZO	Block IQ	
184	QZO	Block IIQ	
185	QZO	Block IIQ	
186	QZO	Block IIA-Q	
189	GEO	Block IIG	

3.2.2. L1S Codes

The PRN code of L1S has a chipping rate of 1.023 Mbps and length of 1 ms (1023 chips) and are modulated by BPSK. The PRN codes are generated as shown in Figure 3.2.2-1 The code pattern of each PRN number is generated with the G2 shift register delay and the initial value shown in Table 3.2.2-1.

The PRN code has the same code sequence as that of the L1C/A signal described in 3.2.2 of IS-QZSS-PNT.

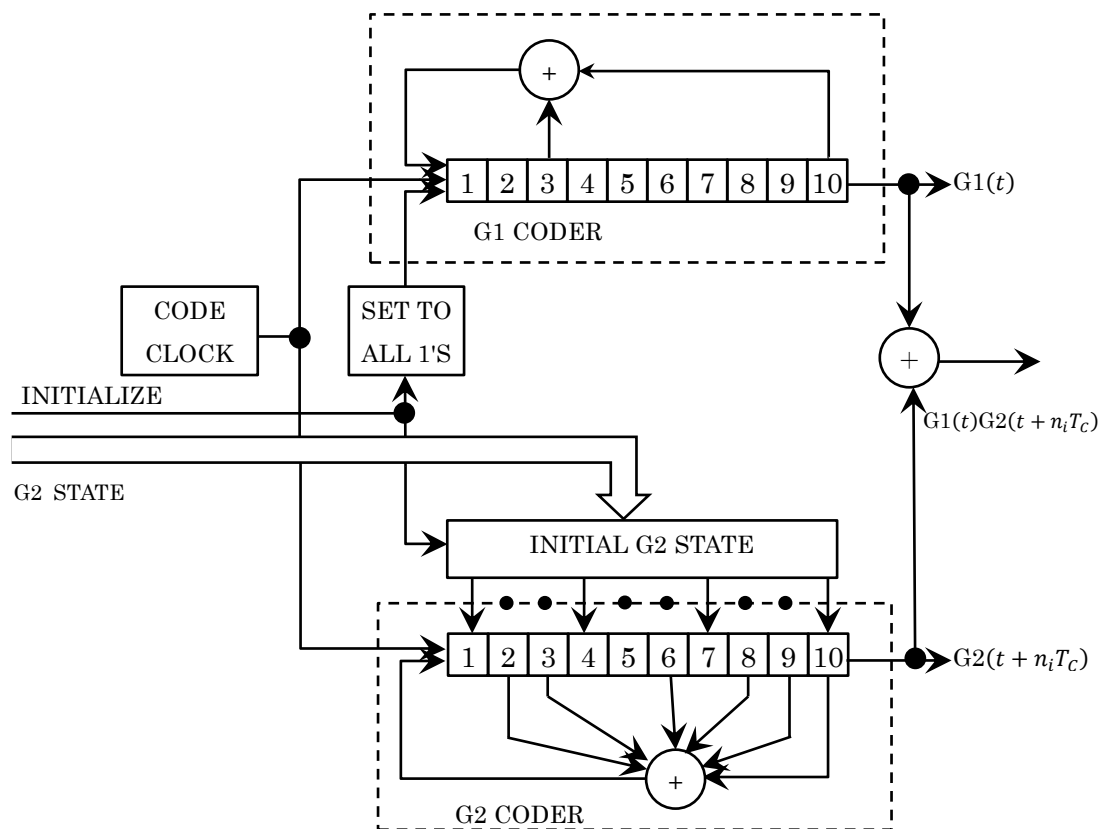

Figure 3.2.2-1 L1S Code Generator

Table 3.2.2-1 L1S PRN Code phase assignment

PRN Number	G2 Delay (chips)	G2 Initial Value (octal)	First 10 Chips (octal)
183	144	0215	1562
184	476	1003	0774
185	193	1454	0323
186	109	1665	0112
189	87	0307	1470

3.2.3. Non-Standard Codes

L1S signals have no non-standard codes.

4. Message Specifications

4.1. L1S

4.1.1. Message Configuration

4.1.1.1. Overview

Each message are transmitted by L1S signal, consist of 250 bits format shown in Figure 4.1.1-1. The single message is transmitted in one second (250 bps).

Each message consist of 8-bit preamble (PAB), 6-bit message type ID (MT), 212-bit data field (DATA FIELD) and 24-bit CRC (CRC) . The message transmission sequence is not specified; each message may be transmitted in any one-second period.

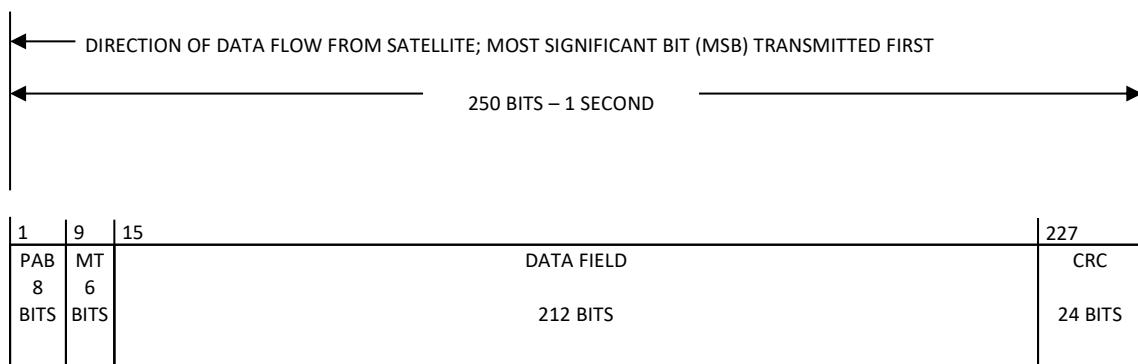

Figure 4.1.1-1 Message Block Format

4.1.1.2. Timing

(1) Transmission Satellite

Normally, all satellites have the same SLAS message except MT44 transmitted by L1S signal without some failure. See chapter 4.2.2 of the applicable document (3) for the assignment of satellites transmitting MT44.

(2) Transmission Interval

Table 4.1.1-1 shows the maximum transmission intervals.

Table 4.1.1-1 Maximum Transmission Intervals

Message Data	MT	Maximum Transmission Intervals [second]
Test mode	0	30*
DC Report	43	4(nominal)**
DCX message	44	4(nominal)*****
Monitoring station information	47	60***
PRN mask	48	30
IOD information	49	60
DGPS correction	50	30
Satellite health	51	(N/A)****
Null message	63	(N/A)

* Test mode

Transmitted at test mode only.

** DC report

Transmitted MT 43. MT 63 is transmitted if there is no DC Report.

A higher priority MT44 may be sent instead of the MT43.

*** Monitoring station information

MT47 contains 5 Monitoring station information at maximum, in one message.

In case that Monitoring station information are 13, the cycle of a Monitoring station information is 180 seconds (3 messages).

**** Satellite health

MT 51 is transmitted three times at 2 second intervals to prevent receiving failure.

***** DCX message

MT44 is not transmitted once every 60 seconds, and MT47 is transmitted instead.

MT44 with high priority may be sent in 2 second intervals.

MT 63 is transmitted if there is no DCX message.

(3) Update Interval and Validity Period

Table 4.1.1-2 shows the nominal update intervals and validity periods.

Table 4.1.1-2 Effective Period

Message Data	MT	Nominal Update Interval	Validity period [second]
Test mode	0	-	(N/A)*
DC Report	43	-	(N/A)
DCX message	44	-	(N/A)
Monitoring station information	47	-	86400
PRN mask	48	30sec	60
IOD information	49	30sec	60
DGPS correction	50	30sec	60
Satellite health	51	30sec	30
Null message	63	-	(N/A)

* See Section 4.1.2.3. for details.

4.1.1.3. Cyclic Redundancy Check (CRC)

The 24-bit CRC bit string is generated by the following generator polynomial $g(X)$.

$$g(X) = X^{24} + X^{23} + X^{18} + X^{17} + X^{14} + X^{11} + X^{10} + X^7 + X^6 + X^5 + X^4 + X^3 + X + 1$$

4.1.1.4. Forward Error Correction (FEC)

The bit string will be Forward Error Correction (FEC) encoded by a 1/2 rate convolutional code. 250-bps messages are encoded to 500-sps symbols. The convolutional coding will be constraint length 7, with a convolutional encoder logic arrangement as shown in Figure 4.1.1-2. The G1 symbol is selected on the output as the first half of a 4-millisecond data bit period and the G2 symbol is the second half.

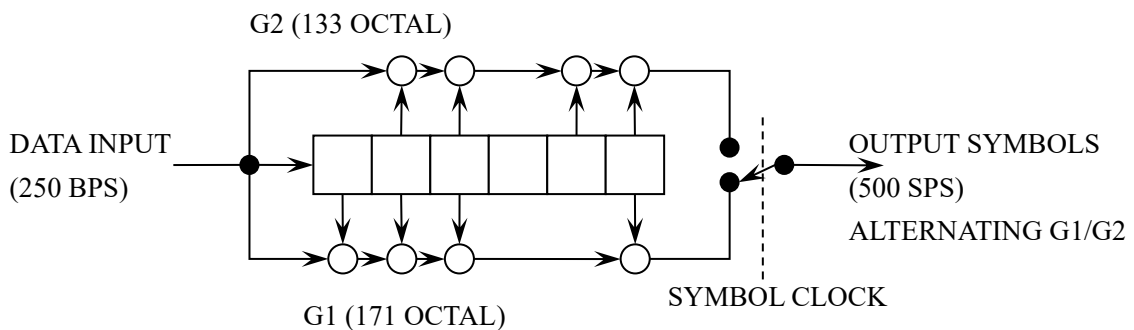

Figure 4.1.1-2 FEC Generation Method

4.1.2. Message Contents

4.1.2.1. Overview

The content shown in Table 4.1.2-1 are stored in each MT of messages.

The ephemeris data required for the user to calculate the orbit of QZSS and GPS shall be received from the L1C/A navigation messages.

Table 4.1.2-1 Message Type

MT	Description
0	Test Mode
43	DC Report
44	DCX message
47	Monitoring Station Information
48	PRN Mask
49	Data Issue Number
50	DGPS Correction
51	Satellite Health
63	Null message

4.1.2.2. Common Section

All MT of L1S messages contain the common parameters shown in Figure 4.1.2-1 and Table 4.1.2-2.

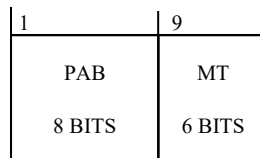

Figure 4.1.2-1 Common Sections of Sub-meter Level Augmentation Messages

Table 4.1.2-2 Parameter Definitions of Common Sections of Sub-meter Level Augmentation Messages

Parameter	Description	Effective Range	Number of Bits	LSB	Units
PAB	Preamble	-	8	-	-
MT	Message Type ID	0-63	6	1	-

(1) Preamble

The beginning of each message is the 8-bit preamble consists of the following three patterns repeated in sequence:

Pattern A	01010011
Pattern B	10011010
Pattern C	11000110

The first bit in the “Pattern A” preamble is synchronous with the epoch of the 6-second L1C/A signal (signal for GPS and QZSS satellite positioning services) navigation message subframe. ”Pattern B” comes after “Pattern A”. “Pattern C” comes after “Pattern B”. After that, the sequence returns to “Pattern A”.

FEC encoding is transformed for preambles in the same coding (See Section 4.1.1.4). Accordingly, while the preamble indicates the beginning of the message block, it cannot be used for signal acquisition prior to FEC decoding or for bit synchronization.

(2) Message Type

The types of this message are shown below. See Table 4.1.2-1 for details about the message types.

4.1.2.3. Message Type 0: Test Mode

MT 0 indicates that LIS signal of the QZS is in test mode. When receiving MT 0, the receiver should delete all SLAS messages of the QZS in the past, and SLAS messages of the QZS for the subsequent 60 seconds must also not be used.

4.1.2.4. Message Type 43: DC Report (JMA Disaster Prevention Information)

This is DC Report of the Japan Meteorological Agency Disaster Prevention Information (JMA-DCR).

Figure 4.1.2-2 shows the data format. Refer to Section 2.1(2) for the “DATA FIELD” in Figure 4.1.2-2 and its data definition.

See chapter 4.3 of the applicable document (2) about DC Report message output from a receiver.

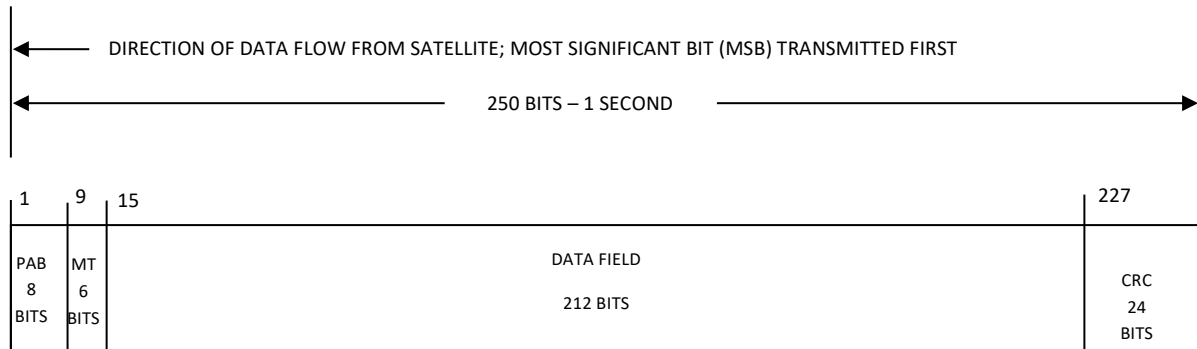

Figure 4.1.2-2 Format (Disaster Prevention Information)

4.1.2.5. Message Type 44: DCX message

Message type 44 (MT44) is used to transmit DCX message (L-Alert), DCX message (J-Alert), DCX message (municipality-transmitted information[tentative name]), and DCX message (overseas organization signals).

Figure 4.1.2-3 shows the data format. Refer to Section 2.1(3) for the “DATA FIELD” in Figure 4.1.2-3 and its data definition.

See chapter 4.4 of the applicable document (3) about DCX message output from a receiver.

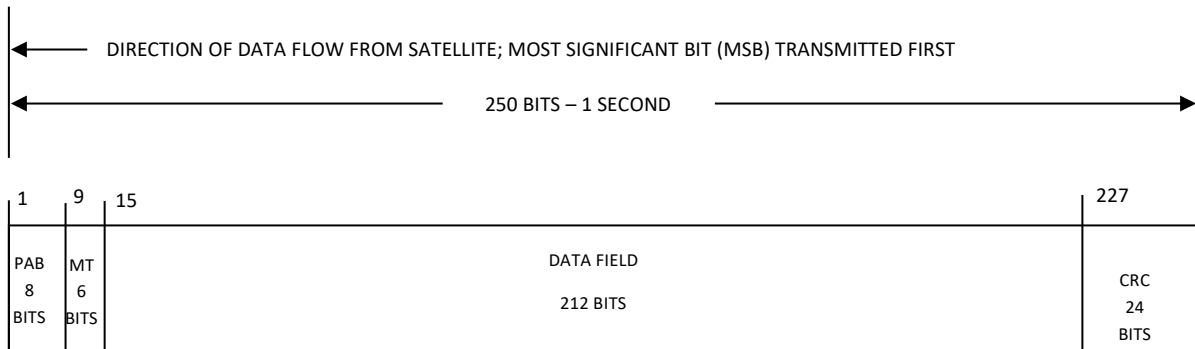

Figure 4.1.2-3 Format (DCX message)

4.1.2.6. Message Type 47: Monitoring Station Information

Figure 4.1.2-4 shows the data format and Table 4.1.2-3 shows its parameter definitions.

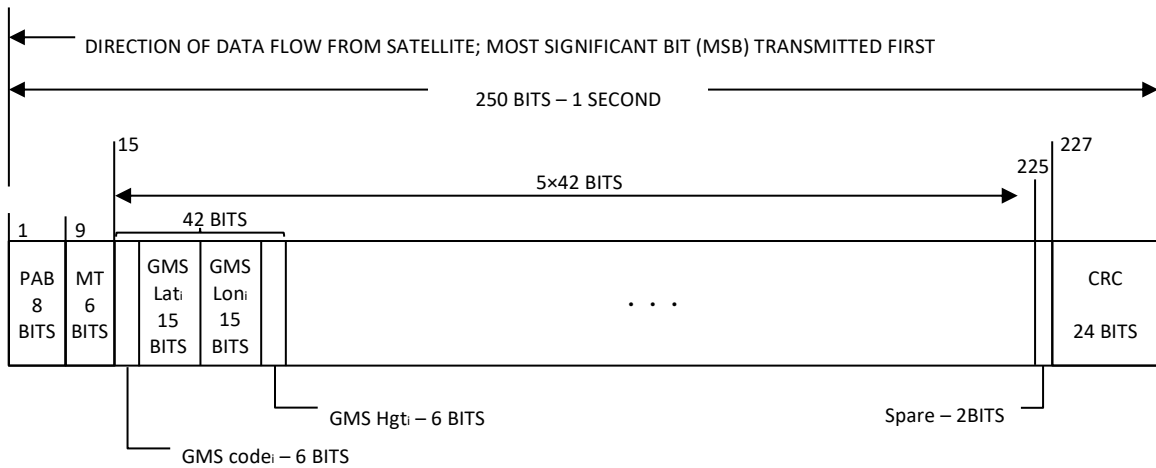

Figure 4.1.2-4 Message type 47: Monitoring station information Format

Table 4.1.2-3 Parameter definitions

Parameter	Description	Effective range	Number of Bits	LSB	Units
-	PAB and MT (See section 4.1.2.2.)	-	-	-	-
GMS code ₁	Monitoring station code (1)	0 - 63	6	1	-
GMS Loc ₁	GMS Lat ₁	latitude (1)	15***	0.005	deg
	GMS Lon ₁	longitude (1)	15***	0.005	deg
	GMS Hgt ₁	ellipsoidal height (1)	6	50	m
:	:				
GMS code ₅	Monitoring station code (5)	0 - 63	6	1	-
GMS Loc ₅	Monitoring station location (5)		36		
Spare	Spare	-	2	-	-
-	CRC (See section 4.1.1.3.)	-	-	-	-

* Note that the difference is from the standard value +115.00.

** Note that the difference is from the standard value -100.

*** Signed parameter

(1) Monitoring station code

See Table 4.1.2-4.

In the case of GMS ID "63", the Monitoring station location is not applicable.

Table 4.1.2-4 GMS ID

ID	Monitoring Station	Coordinate value		
		Lat[deg]	Lon[deg]	Hgt[m]
0	Sapporo	43.15	141.22	50
1	Sendai	38.27	140.74	200
2	Spare	—	—	—
3	Hitachiota	36.58	140.55	150
4	Spare	—	—	—
5	Komatsu	36.40	136.41	50
6	Kobe	34.71	135.04	200
7	Hiroshima	34.35	132.45	50
8	Fukuoka	33.67	130.39	50
9	Tanegashima	30.55	130.94	100
10	Amami	28.42	129.69	50
11	Itoman	26.15	127.69	100
12	Miyako	24.73	125.35	100
13	Ishigaki	24.37	124.13	100
14	Chichijima	27.09	142.19	100
15 to 62	Spare	—	—	—
63	(N/A)	—	—	—

(2) Monitoring station location

The latitude, the longitude and the ellipsoidal height of the monitoring station. For each GMS ID, the monitoring station location transmitted via MT47 shall take precedence over the one defined in this document.

4.1.2.7. Message Type 48: PRN Mask

Figure 4.1.2-5 shows the data format and Table 4.1.2-5 shows its parameter definition.

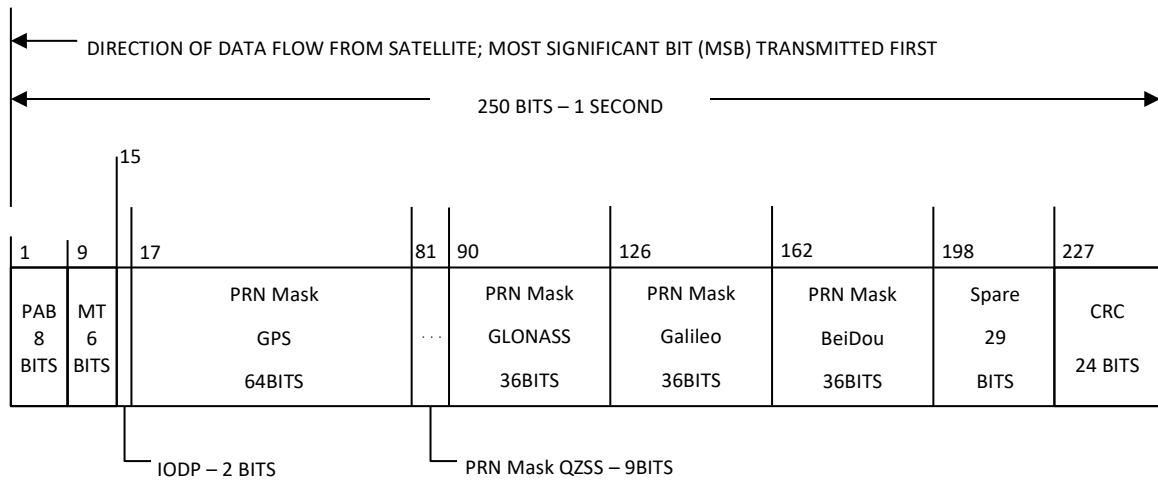

Figure 4.1.2-5 Message Type 48: PRN mask Format

Table 4.1.2-5 Parameter Definitions

Parameter	Description	Effective Range	Number of Bits	LSB	Unit
-	PAB and MT (See 4.1.2.2.)	-	-	-	-
IODP	PRN mask updating number	0 - 3	2	1	-
PRN Mask	Number ₁₇	GPS (1)	0 - 1	1	-
	:	:			
	Number ₈₀	GPS (64)	0 - 1	1	-
	Number ₈₁	QZSS (1)	0 - 1	1	-
	:	:			
	Number ₈₉	QZSS (9)	0 - 1	1	-
	Number ₉₀	GLONASS (1)	0 - 1	1	-
	:	:			
	Number ₁₂₅	GLONASS (36)	0 - 1	1	-
	Number ₁₂₆	Galileo (1)	0 - 1	1	-
	:	:			
	Number ₁₆₁	Galileo (36)	0 - 1	1	-
	Number ₁₆₂	BeiDou (1)	0 - 1	1	-
	:	:			
Number ₁₉₇	BeiDou (36)	0 - 1	1	-	
Spare	Spare	-	29	-	-
-	CRC (See 4.1.1.3.)	-	-	-	-

(1) PRN mask updating number (IODP)

The incremented number when the PRN mask is updated and is cyclically used as 0 after 3. This IODP corresponds to IODP of Message Type 49 and 50.

(2) PRN Mask Number

1-bit flag of a selected satellite for augmentation. The correspondence between Mask number and PRN number or Slot number is shown in Table 4.1.2-6.

Mask numbers are set to "1" for up to 23 satellites.

Table 4.1.2-6 Correspondence between Mask number and PRN number or Slot number

Mask Number	Satellite System	Correspondence
17 to 80	GPS	PRN number = Mask number -16
81 to 89	QZSS	PRN number = Mask number +112
90 to 125	GLONASS	Slot number = Mask number -89
126 to 161	Galileo	PRN number = Mask number -125
162 to 197	BeiDou	PRN number = Mask number -161

4.1.2.8. Message Type 49 : Data Issue Number

Figure 4.1.2-6 shows the data format and Table 4.1.2-7 shows its parameter definitions.

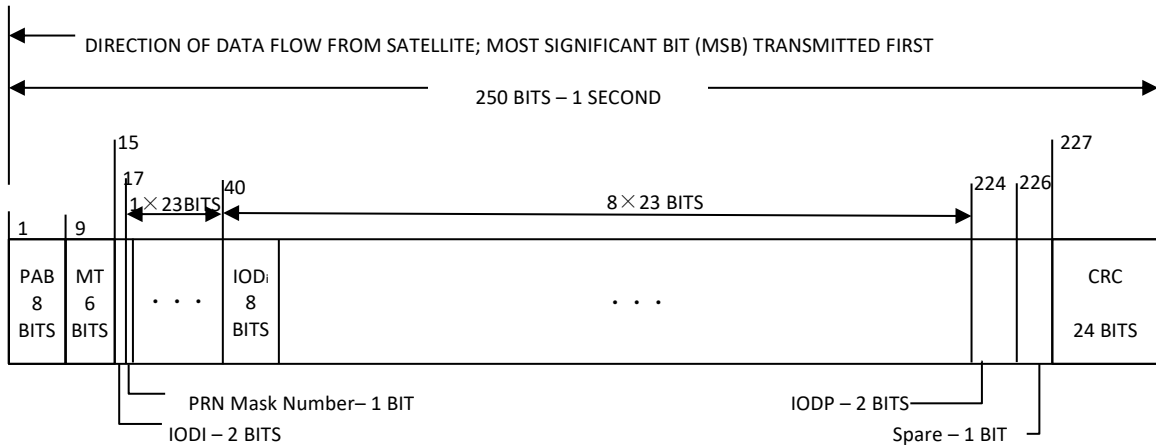

Figure 4.1.2-6 Message Type 49: IOD information Format

Table 4.1.2-7 Parameter definitions

Parameter	Description	Effective Range	Number of Bits	LSB	Unit
-	PAB and MT (See 4.1.2.2.)	-	-	-	-
IODI	IOD updating number	0 - 3	2	1	-
Mask-SV ₁	Mask Selected Satellite (1)	0 - 1	1	1	-
:					
Mask-SV ₂₃	Mask Selected Satellite(23)	0 - 1	1	1	-
IOD ₁	Data issue number (1)	0 - 255	8	1	-
:					
IOD ₂₃	Data issue number (23)	0 - 255	8	1	-
IODP	PRN mask updating number	0 - 3	2	1	-
Spare	Spare	-	1	-	-
-	CRC (See 4.1.1.3.)	-	-	-	-

(1) IOD updating number (IODI)

The incremented number when IOD or IODP are updated and is cyclically used as 0 after 3. This IODI corresponds to IODI of the Message Type 50.

(2) Mask Selected Satellite (Mask-SV)

The selected satellites by PRN Mask of Message Type 48 in order. The augmentation possible satellite is set to "1" and the augmentation impossible satellite is set to "0" if PRN Mask of Message Type 48 is set to "1".

This BIT-SV corresponds to BIT-SV of the Message Type 50.

(3) Data issue number (IOD)

This is the data issue number that corresponding to "BIT-1" of each Mask-SV. The relationship between Message Type 48 and Message Type 49 is shown in Figure 4.1.2-7. This data issue number is given so that they correspond to the IODE of the satellite Ephemeris, respectively.

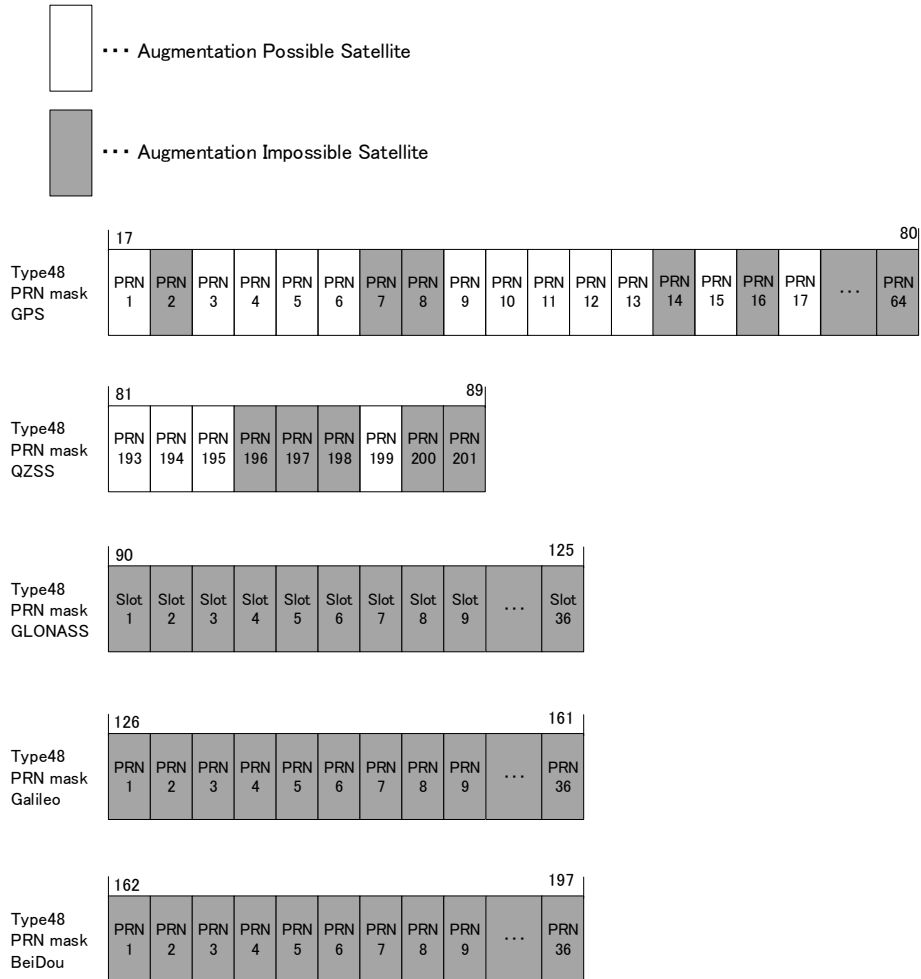

Figure 4.1.2-7 (1/2) Correspondence between PRN Mask and Mask-SV

4.1.2.9. Message Type 50: DGPS Correction

Figure 4.1.2-8 shows the data format and Table 4.1.2-8 shows its parameter definitions.

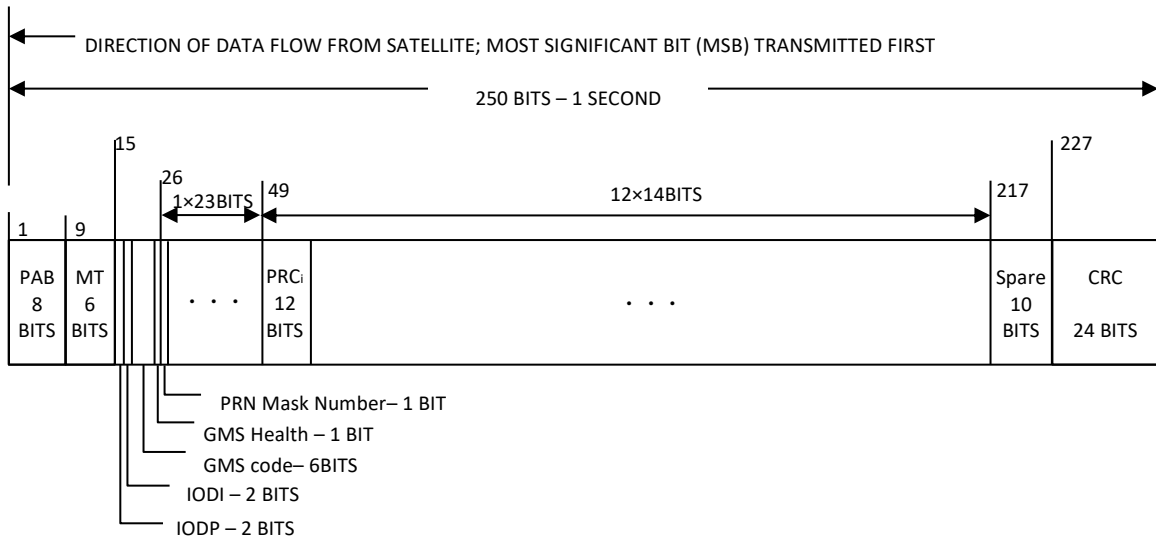

Figure 4.1.2-8 Message Type 50: DGPS Correction Format

Table 4.1.2-8 Parameter Definitions

Parameter	Description	Effective Range	Number of Bits	LSB	Units
-	PAB and MT (See Section 4.1.2.2.)	-	-	-	-
IODP	PRN mask updating number	0 - 3	2	1	-
IODI	IOD updating number	0 - 3	2	1	-
GMS code	Monitoring Station Code	0-63	6	1	-
GMS Health	Monitoring Station Health	0-1	1	1	-
Mask-SV ₁	Mask Selected Satellite (1)	0 - 1	1	1	-
:					
Mask-SV ₂₃	Mask Selected Satellite (23)	0 - 1	1	1	-
PRC ₁	Pseudorange correction (1)	-81.92* - +81.88	12**	0.04	m
:					
PRC ₁₄	Pseudorange correction (14)	-81.92* - +81.88	12**	0.04	m
-	CRC (See Section 4.1.1.3.)	-	-	-	-

* The satellite shall be deemed as unhealthy and shall not be used for 30 seconds.

**Signed parameter

(1) PRN mask updating number (IODP)

This IODP corresponds to IODP of Message Type 48 and 49. See Section 4.1.2.7. (1) .

- (2) IOD updating number (IODI)
This IODI corresponds to IODI of Message Type 49. See Section 4.1.2.8(1)
- (3) Monitoring Station Code (GMS code)
See Section 4.1.2.6. (1)
- (4) Monitoring Station Health (GMS Health)
1-bit health of the monitoring station as follows: "0: Healthy", "1: Unhealthy"
- (5) Mask Selected Satellite (Mask-SV)
See Section 4.1.2.8. (2)
- (6) Pseudorange correction (PRC)
This is the PRC that corresponding to "BIT-1" of each Mask-SV. The relationship between Message Type 48 and Message Type 50 is shown in Figure 4.1.2-7. This PRC is sent by a Message Type 50 each Monitoring Station.

4.1.2.10. Message Type 51: Satellite Health

Figure 4.1.2-9 shows the data format and Table 4.1.2-9 shows its parameter definitions.

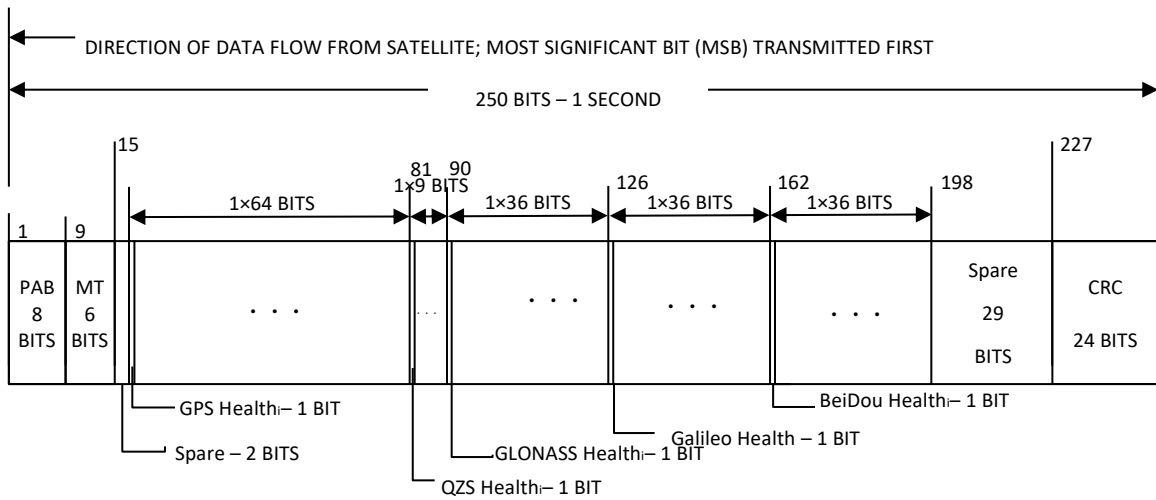

Figure 4.1.2-9 Message Type 51: Satellite health information Format

Table 4.1.2-9 Parameter Definition

Parameter	Description	Effective Range	Number of Bits	LSB	Unit	
-	PAB and MT (See 4.1.2.2.)	-	-	-	-	
Spare	Spare	0	2	-	-	
Satellite Health	Number ₁₇	nGPS (1)	0 - 1	1	1	-
	:					
	Number ₈₀	GPS (64)	0 - 1	1	1	-
	Number ₈₁	QZSS (1)	0 - 1	1	1	-
	:					
	Number ₈₉	QZSS (9)	0 - 1	1	1	-
	Number ₉₀	GLONASS (1)	0 - 1	1	1	-
	:					
	Number ₁₂₅	GLONASS (36)	0 - 1	1	1	-
	Number ₁₂₆	Galileo (1)	0 - 1	1	1	-
	:					
	Number ₁₆₁	Galileo (36)	0 - 1	1	1	-
	Number ₁₆₂	BeiDou (1)	0 - 1	1	1	-
:						
Number ₁₉₇	BeiDou (36)	0 - 1	1	1	-	
Spare	Spare	0	29	-	-	
-	CRC (See 4.1.1.3.)	-	-	-	-	

(1) Satellite Health

The operating status of satellites as follows: "0: Healthy", "1: Unhealthy". Note that these "0" and "1" is opposite to Mask-SV.

Do not use the augmentation data of the satellite until Message Type 48 is updated next time (maximum 30 seconds) if it is unhealthy.

4.1.2.11. Message Type 63: Null Message

Figure 4.1.2-10 shows the data format and Table 4.1.2-10 shows its parameter definitions.

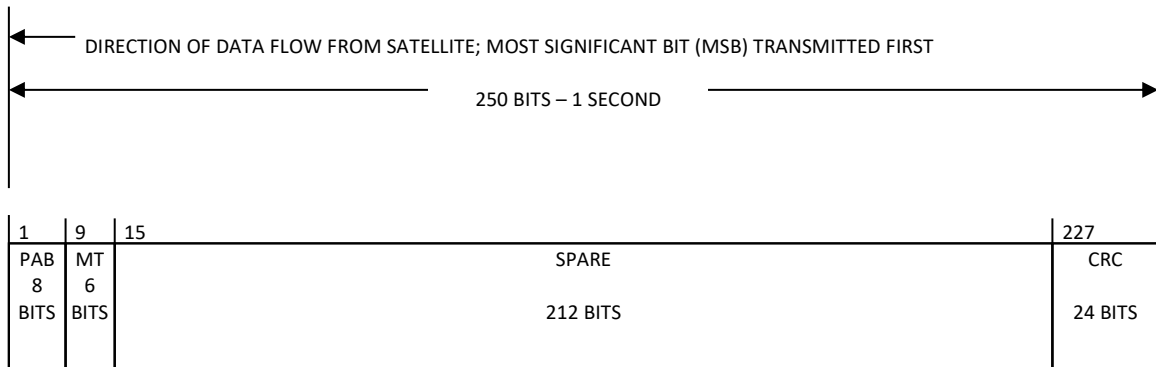

Figure 4.1.2-10 Message Type 63: Null Message Format

Table 4.1.2-10 Parameter Definitions

Parameter	Description	Effective Range	Number of Bits	LSB	Units
-	PAB and MT (See Section 4.1.2.2.)	-	-	-	-
Spare	Spare	-	212	1	-
-	CRC (See Section 4.1.1.3.)	-	-	-	-

(1) Spare

Fix to "0" for spare.

5. User Algorithm

5.1. Time System

The SLAS time system shall be the QZSS time system (QZSST) shown below.

(1) Definitions

(a) Length of 1 second

The length of one second in QZSST shall be identical to the International Atomic Time (TAI).

(b) Offset between QZSST and TAI

QZSST shall be delayed from TAI by 19 second.

(c) Starting point of week number for QZSST

The starting point of the week number for QZSST shall be the same as that of the GPS time system (GPST), which is 0:00 a.m. (UTC) on January 6, 1980.

(2) Parameter Reference Time

Parameters represented by time-function parameters transmitted on L1S signals by QZS shall all be expressed by using QZSST as reference time.

5.2. Coordinate System

The SLAS coordinate system is defined as follows.

- Origin: Mass center of the earth
- Z axis: the IERS Reference north pole
- X axis: intersection of the IERS Reference Meridian (IRM) and the equatorial plane.
- Y axis: complete a right-handed, Earth-centered, Earth-Fixed (ECEF) orthogonal coordinate system

This is the same coordinate system described in 5.2 of IS-QZSS-PNT.

5.3. Constants

(1) Circular Constant

$$\pi = 3.1415926535898.$$

(2) Earth's Equatorial Radius

$$R_e = 6378137 \text{ m.}$$

(3) Ionospheric Altitude

$$h_i = 350,000 \text{ m.}$$

5.4. Health and Alert Flag

The health and Alert flags indicate the information of L1S messages used for augmentation. The following table shows the types and descriptions of the health and alert information contained in the messages.

The unhealthy conditions of SLAS are shown in Table 5.4-1 of Applicable Document (1) "PS-QZSS".

Table 5.4-1 Information of L1S messages used for augmentation

Alert Information	Message Type	Description
Monitoring station health (GMS Health)	50	Indicate the condition of augmentation When GMS Health = 1, do not use all augmentation data of the related monitoring station.
Pseudorange correction value (PRC)	50	Indicate the condition of augmentation When PRC = -81.92, do not use the augmentation data of the related satellite.
Satellite health (SV health)	51	Indicate the condition of augmentation When SV Health = 1, do not use the augmentation data of the related satellite.

5.5. Procedure for Applying Correction Information

SLAS messages used to calculate the augmented position contain message type 47, 48, 49, 50 and 51.

5.5.1. Selection of the SLAS messages transmitted satellite

SLAS shall be selected one QZS to receive the SLAS messages.

For switching from one QZS to another, SLAS messages from the two QZS shall be received independently before the switching; the switching shall be performed when all messages for augmentation has been received.

When receiving two or more QZSs, it is recommended to receive two QZSs at the same time and to switch the satellite to maximize the continuity.

5.5.2. Augmentation Using DGPS Correction

User positions are calculated by using message type 50 (DGPS correction). Pseudorange correction values to be applied must be those contained within message type 50 with the same IODP and IODI as that contained in the ephemeris of the target satellite. The last received message type 50 shall be used for computing SLAS position solution.

The ionospheric delay correction and the tropospheric delay correction are included in the pseudorange correction value. Users shall adapt the following additional corrections:

- The correction of SV clock broadcasting from GPS and QZSS
- The correction of TGD(Timing Group Delay)
- The correction of residual relativistic effect of orbit eccentricity
- The correction of Sagnac effect

(1) Selection of the monitoring station (Message Type 47)

Users select the nearest monitoring station to the receiver point calculated by single point positioning. Users select an alternative monitoring station to the selected station if GMS Health of the selected station is "1: Unhealthy". Table 5.5-1 shows the combinations of alternative monitoring stations corresponding to each monitoring station.

Table 5.5-1 Combination of Alternative Monitoring Stations

ID	Monitoring Station	Alternative Monitoring Stations	
0	Sapporo	Sendai	
1	Sendai	Sapporo	Hitachiota
3	Hitachiota	Sendai	Komatsu
5	Komatsu	Hitachiota	Kobe
6	Kobe	Komatsu	Hiroshima
7	Hiroshima	Kobe	Fukuoka
8	Fukuoka	Hiroshima	Tanegashima
9	Tanegashima	Fukuoka	Amami
10	Amami	Tanegashima	Itoman
11	Itoman	Amami	Miyako
12	Miyako	Itoman	Ishigaki
13	Ishigaki	Miyako	
14	Chichijima		

(2) Selection of the augmented satellites (Message Type 48 and 49)

SLAS Positioning shall be calculated using healthy satellites (GPS and QZS) at elevation angles of more than 5 degrees.

As the result of satellite selection, the following number of satellites is output.

$N(t, p)$: The number of satellites at receiver point "p" at time "t"

Users store IODP and IODI of the selected satellites in order to select corresponding correction in message type 50.

(3) Calculation of the correction value (Message Type 50)

Corrected Pseudoranges ($PR_i^{corrected}$) are calculated from Pseudorange Correction (PRC_i) of Message Type 50 and observed Pseudorange ($PR_i^{measured}$) by receivers follows.

$$PR_i^{corrected} = PR_i^{measured} + PRC_i \quad \text{Formula 5.5-1}$$

$PR_i^{corrected}$: Corrected Pseudorange
$PR_i^{measured}$: Measured Pseudorange
PRC_i	: Pseudorange correction (PRC)
i	: PRN number

The geometric distance between the receiver and the satellite (R_i) is calculated as follows.

$$R_i = \sqrt{(x_i - x_{rc})^2 + (y_i - y_{rc})^2 + (z_i - z_{rc})^2} \quad \text{Formula 5.5-2}$$

R_i : Geometric satellite-user distance
 x_{rc}, y_{rc}, z_{rc} : Approximate user position
 x_i, y_i, z_i : Satellite position by ephemeris
 i : PRN number

Pseudorange Difference ($dPR_i^{corrected}$) is calculated from Formula 5.5-1 and Formula 5.5-2 as follows.

$$dPR_i^{corrected} = PR_i^{corrected} - R_i \quad \text{Formula 5.5-3}$$

$dPR_i^{corrected}$: Pseudorange Difference
 $PR_i^{corrected}$: Corrected Pseudorange
 R_i : Geometric satellite-user distance
 i : PRN number

The user position (POS) is calculated by the weighted least squares method shown as follows.

$$POS = (G^T \cdot W \cdot G)^{-1} \cdot G^T \cdot W \cdot dPR^{corrected} \quad \text{Formula 5.5-4}$$

$$G = \begin{bmatrix} -\cos EL_1 \sin AZ_1 & -\cos EL_1 \cos AZ_1 & -\sin EL_1 & 1 \\ -\cos EL_2 \sin AZ_2 & -\cos EL_2 \cos AZ_2 & -\sin EL_2 & 1 \\ \vdots & \vdots & \vdots & \vdots \\ -\cos EL_N \sin AZ_N & -\cos EL_N \cos AZ_N & -\sin EL_N & 1 \end{bmatrix} \quad \text{Formula 5.5-5}$$

$$W = \begin{bmatrix} \frac{1}{\sigma_1^2} & 0 & \dots & 0 \\ 0 & \frac{1}{\sigma_2^2} & \dots & 0 \\ \vdots & \vdots & \ddots & \vdots \\ 0 & 0 & \dots & \frac{1}{\sigma_N^2} \end{bmatrix} \quad \text{Formula 5.5-6}$$

POS	: User position
G	: Observation matrix
W	: Weighting matrix
$dPR_i^{corrected}$: Pseudorange difference
EL_i	: Satellite elevation angle
AZ_i	: Satellite azimuth
σ_i^2	: Error variance
i	: PRN number

$$\sigma_i^2 = \sigma_{pr_gnd,i}^2 + \sigma_{air,i}^2 + \sigma_{iono,i}^2 \quad \text{Formula 5.5-7}$$

$\sigma_{pr_gnd,i}^2$: Error component of pseudorange correction value
$\sigma_{air,i}^2$: Receiver noise error and multipath error component
$\sigma_{iono,i}^2$: Ionospheric error component
i	: PRN number

$$\sigma_{pr_gnd,i}^2 = \frac{(a_0 + a_1 e^{-EL_i/Th_0})^2}{n} + a_2^2 \quad \text{Formula 5.5-8}$$

$a_0 = 0.16$	} : Setting parameters
$a_1 = 1.07$	
$a_2 = 0.08$	
$Th_0 = 15.5$	
$n = 1$	
EL_i	: Satellite elevation angle deg
i	: PRN number

$$\sigma_{air,i}^2 = \sigma_{noise}^2 + \sigma_{multi,i}^2 \quad \text{Formula 5.5-9}$$

$\sigma_{noise} = 0.11$: Receiver noise error component
$\sigma_{multi} = 0.13 + 0.53e^{-EL_i/10}$: Multipath error component
EL_i	: Satellite elevation angle deg
i	: PRN number

$$\sigma_{iono,i} = F_{pp,i} \cdot \sigma_{vig}(dist + 2\tau v_{air}) \quad \text{Formula 5.5-10}$$

$\sigma_{vig} = 0.004$	} : Setting parameter
$\tau = 100$	
$v_{air} = 0.07$	
$F_{pp,i}$: Vertical-to-slant obliquity factor
dist	: Monitoring station-user distance km
i	: PRN number

$$F_{pp,i} = \left[1 - \left(\frac{R_e \cos EL_i}{R_e + h_i} \right)^2 \right]^{-1/2}$$

Formula 5.5-11

EL_i : Satellite elevation angle
 R_e : Earth equatorial radius
 h_i : Ionospheric height
 i : PRN number

(4) Alert information (Message Type 51)

If Users receive Message Type 51, they shall exclude unhealthy satellites immediately.

5.5.3. Accuracy

5.5.3.1. Smoothing

In the presence of a code-carrier divergence rate of up to 0.018m/s, the smoothing filter output shall achieve an error less than 0.25m within 200 seconds after initialization, relative to the steady-state response of the following filter.

$$P_{proj} = P_{n-1} + \frac{\lambda}{2\pi}(\phi_n - \phi_{n-1}) \quad \text{Formula 5.5-12}$$

$$P_n = \alpha PR_n^{measured} + (1 - \alpha)P_{proj} \quad \text{Formula 5.5-13}$$

P_n	: Pseudorange smoothed by a carrier [m]
P_{n-1}	: The preceding value of pseudorange smoothed by a carrier [m]
P_{proj}	: Projected pseudorange [m]
λ	: Wavelength [m]
ϕ_n	: Accumulated measured carrier phase [rad]
ϕ_{n-1}	: The preceding value of accumulated measured carrier phase [rad]
α	: Weighting factor of the filter [dimensionless value] α is calculated by dividing the sampling interval [s] at a time constant of 100s
n	: specific time [s]

5.5.3.2. Quality Monitoring

The augmented satellite signal quality shall be monitored to reduce integrity risks caused by undetected cycle slips or other errors.

Do not use if the measured pseudorange is significantly different from projected pseudorange. The following is a recommended method.

$$\begin{aligned} &IF |(PR_n^{measured} - P_{proj})| < 10m \\ &then P_n = P_{proj} + \alpha(PR_n^{measured} - P_{proj}) \\ &Otherwise P_n = P_{proj} \end{aligned} \quad \text{Formula 5.5-14}$$

5.5.3.3. Differential ISB Correction

In SLAS which adopts Differential GNSS (DGNSS) using GPS and QZSS, following correction may be needed by combination of user receiver and base receiver (Monitoring station of Sub-meter Level Augmentation).

- i) Correction of Differential Inter System Bias (DISB) between GPS and QZSS.
- ii) Correction of bias to each satellite in GPS and QZSS in case that bias arises to each satellite in GPS and QZSS.

For details, refer to IS-QZSS-L1S, which will be revised later. Please contact to the following URL (Contact Us).

URL : <https://qzss.go.jp/en/inquiry/>

5.5.3.4. Differential Tropospheric Delay Correction

User can improve positioning accuracy by utilizing Differential Tropospheric Delay Correction (DTDC) to correct tropospheric delay errors included in the PRC_i . The tropospheric delay depends on the elevation angle difference and height difference between the selected monitoring station and the user's position. In this sense, the effectiveness of DTDC increases with a longer baselines from the selected monitoring station to the user's position.

To calculate Corrected Pseudorange ($PR_i^{corrected}$) with DTDC, Formula 5.5-15 should be used instead of Formula 5.5-1.

$$PR_i^{corrected} = PR_i^{measured} + PRC_i + (Trop_i^{user} - Trop_i^{MS}) \quad \text{Formula5.5-15}$$

- $PR_i^{corrected}$: Corrected Pseudorange with additional tropospheric delay correction
- $PR_i^{measured}$: Measured Pseudorange
- PRC_i : Pseudorange correction (PRC)
- $Trop_i^s$: Tropospheric delay correction
s = user: at the user receiver position
s = MS: at the monitoring station position
- i : PRN number

5.5.3.4.1. Tropospheric delay model

This section provides the calculation model for DTDC that can be used in SLAS.

The tropospheric delay correction ($Trop_i^s$) for satellite i and receiver s takes the form Formula5.5-16.

$$Trop_i^s = -(d_{hyd} + d_{wet}) \cdot m(El_i) \quad \text{Formula5.5-16}$$

d	: Estimated zenith tropospheric range delays
hyd	: Hydrostatic equilibrium gases
wet	: Water vapor
$m(EI_i)$: Tropospheric delay mapping function for a satellite elevation angle
i	: PRN Number

$[d_{hyd}, d_{wet}(m)]$ are calculated using the receiver's height and the five meteorological parameters: pressure $[P$ (hPa)], temperature $[T$ (K)], water vapor pressure $[e$ (hPa)], temperature lapse rate $[\beta$ (K/m)] and water vapor "lapse rate" $[\lambda$ (dimensionless)].

The values of these five meteorological parameters, which apply to the receiver latitude $[\varphi]$ and day-of-year $[D]$ (starting with 1 January), are computed using average and seasonal variation values shown in Table 5.5.3-1.

Each parameter value $[\xi]$ is computed as:

$$\xi(\varphi, D) = \xi_o(\varphi) - \Delta\xi(\varphi) \cdot \cos\left(\frac{2\pi(D - 28)}{365.25}\right) \quad \text{Formula 5.5-17}$$

ξ	: Meteorological parameter value (pressure, temperature, water vapor pressure, temperature lapse rate, water vapor lapse rate)
ξ_o	: Average meteorological parameter value shown in Table 5.5.3-1
$\Delta\xi$: Seasonal variation meteorological parameter value shown in Table 5.5.3-1
φ	: Receiver latitude, where $15 \leq \varphi \leq 60$
D	: Day of year

$$\xi_o(\varphi) = \xi_o(\varphi_1) + [\xi_o(\varphi_2) - \xi_o(\varphi_1)] \cdot \left(\frac{\varphi - \varphi_1}{\varphi_2 - \varphi_1}\right) \quad \text{Formula 5.5-18}$$

$$\Delta\xi(\varphi) = \Delta\xi(\varphi_1) + [\Delta\xi(\varphi_2) - \Delta\xi(\varphi_1)] \cdot \left(\frac{\varphi - \varphi_1}{\varphi_2 - \varphi_1}\right) \quad \text{Formula 5.5-19}$$

φ_1, φ_2	: The two latitudes among those listed in Table 5.5.3-1 that are closest to the receiver latitude φ , where $\varphi_1 < \varphi_2$
------------------------	---

Table 5.5.3-1 Meteorological parameters as a function of Latitude for Tropospheric delay

Latitude (°)	Average Parameter (ζ_0)				
	P_0 (hPa)	T_0 (K)	e_0 (hPa)	β_0 (K/m)	λ_0
15	1013.25	299.65	26.31	6.30×10^{-3}	2.77
30	1017.25	294.15	21.79	6.05×10^{-3}	3.15
45	1015.75	283.15	11.66	5.58×10^{-3}	2.57
60	1011.75	272.15	6.78	5.39×10^{-3}	1.81
Latitude (°)	Seasonal Variation Parameter ($\Delta\zeta$)				
	ΔP (hPa)	ΔT (K)	Δe (hPa)	$\Delta\beta$ (K/m)	$\Delta\lambda$
15	0.00	0.00	0.00	0.00	0.00
30	-3.75	7.00	8.85	0.25×10^{-3}	0.33
45	-2.25	11.00	7.24	0.32×10^{-3}	0.46
60	-1.75	15.00	5.36	0.81×10^{-3}	0.74

$$d_{hyd} = \left(1 - \frac{\beta H}{T}\right)^{\frac{g}{R_d \beta}} \cdot z_{hyd} \quad \text{Formula 5.5-20}$$

$$d_{wet} = \left(1 - \frac{\beta H}{T}\right)^{\frac{(\lambda+1)g}{R_d \beta} - 1} \cdot z_{wet} \quad \text{Formula 5.5-21}$$

g : 9.80665 [m/s²]
 H : Receiver's height expressed in units of meters above mean-sea-level [m]

$$z_{hyd} = \left(\frac{10^{-6} k_1 R_d P}{g_m}\right) \quad \text{Formula 5.5-22}$$

$$z_{wet} = \left(\frac{10^{-6} k_2 R_d}{g_m (\lambda + 1) - \beta R_d}\right) \cdot \frac{e}{T} \quad \text{Formula 5.5-23}$$

z : Zero-altitude zenith tropospheric delays
 k_1 : 77.604 [K/hPa]
 k_2 : 382000 [K²/hPa]
 R_d : 287.054 [J/(kg·K)]
 g_m : 9.784 [m/s²]

$$m(El_i) = \frac{1.001}{\sqrt{0.002001 + \sin^2(El_i)}} \quad \text{Formula 5.5-24}$$